

# Hidros

INNOVATION AS ENERGY



AN ENX TECHNOLOGIES COMPANY

## GENERAL CATALOGUE

## HEAT PUMP SYSTEMS

LSA/HP	HIGH EFFICIENCY AIR TO WATER HEAT PUMPS	10
LHi	HIGH EFFICIENCY AIR TO WATER HEAT PUMPS WITH INVERTER COMPRESSOR	14
LHA	HIGH EFFICIENCY AIR TO WATER HEAT PUMPS	22
LHE	HIGH EFFICIENCY AIR TO WATER HEAT PUMPS WITH LOW GWP REFRIGERANT	32
LZT	HIGH EFFICIENCY AIR TO WATER HEAT PUMPS WITH E.V.I. COMPRESSORS	42
LZTi	HEAT PUMPS AIR/WATER DC INVERTER COMPRESSOR WITH VAPOR INJECTION (EVI)	56
WZT	HIGH EFFICIENCY AIR TO WATER HEAT PUMPS WITH E.V.I. COMPRESSORS IN TWO SECTIONS	60
WZA	GROUND SOURCE WATER TO WATER HEAT PUMPS	66
WHA	GROUND SOURCE WATER TO WATER HEAT PUMPS	70
WHK	SUPER-HIGH TEMPERATURE WATER TO WATER HEAT PUMPS	76

## HEAT PUMP SYSTEMS

LHi/P4	4 PIPE SYSTEMS HIGH EFFICIENCY AIR TO WATER HEAT PUMPS WITH INVERTER COMPRESSOR	80
LHA/P4	4 PIPE SYSTEMS HIGH EFFICIENCY AIR TO WATER HEAT PUMPS	88
LHE/P4	HIGH EFFICIENCY AIR TO WATER HEAT PUMPS WITH LOW GWP REFRIGERANT	102
LZT/P4	4 PIPE SYSTEMS HIGH EFFICIENCY AIR TO WATER HEAT PUMPS WITH E.V.I. COMPRESSORS	112

## STORAGE TANKS

TFW - TFWS	DOMESTIC HOT WATER CYLINDERS	122
TFP - TFPS	HOT WATER STORAGE TANKS	124
TFF	HOT AND COLD WATER STORAGE TANKS	126
TFH - TFHS	DOMESTIC HOT WATER GENERATORS	128
TFA - TFAS	DOMESTIC HOT WATER STORAGE TANKS	130
PI	DOMESTIC HOT WATER HEAT STATIONS	132
SCP	PLATE HEAT EXCHANGERS FOR DOMESTIC HOT WATER PRODUCTION	134
RG	CONTROL SYSTEMS AND COMPONENTS	136
S.I.	HEAT PUMP SYSTEMS	139

## DEHUMIDIFIERS

<b>FH - GH</b>	DEHUMIDIFIERS FOR RADIANT COOLING SYSTEMS	146
<b>GHE</b>	DEHUMIDIFIERS FOR RADIANT COOLING SYSTEMS WITH HEAT RECOVERY	150
<b>FHE</b>	DEHUMIDIFIERS FOR RADIANT COOLING SYSTEMS WITH HEAT RECOVERY	156
<b>HBA</b>	INDUSTRIAL DEHUMIDIFIERS	162
<b>HHA</b>	INDUSTRIAL DEHUMIDIFIERS	166
<b>HDA</b>	INDUSTRIAL DEHUMIDIFIERS	170
<b>NHA - NHA Z</b>	INDUSTRIAL DEHUMIDIFIERS WITH TEMPERATURE CONTROL	174
<b>HMA</b>	INDUSTRIAL DEHUMIDIFIERS	178
<b>HMA Z</b>	INDUSTRIAL DEHUMIDIFIERS WITH TEMPERATURE CONTROL	182
<b>HMA BT</b>	LOW TEMPERATURE INDUSTRIAL DEHUMIDIFIERS	186
<b>SBA</b>	SWIMMING POOL DEHUMIDIFIERS	190
<b>SBA HT</b>	SWIMMING POOL DEHUMIDIFIERS FOR HIGH AMBIENT TEMPERATURE	194
<b>SHA</b>	SWIMMING POOL DEHUMIDIFIERS	198
<b>SDA</b>	SWIMMING POOL DEHUMIDIFIERS	202
<b>NSA</b>	SWIMMING POOL DEHUMIDIFIERS	206
<b>SMA</b>	SWIMMING POOL DEHUMIDIFIERS	210
<b>SRH</b>	SWIMMING POOL DEHUMIDIFIERS	214
<b>UTA - UTAZ</b>	ENERGY RECOVERY HIGH EFFICIENCY DEHUMIDIFIERS	218

## CHILLERS

<b>LDA</b>	AIR COOLED WATER CHILLERS WITH AXIAL FANS	224
------------	---	-----

## **HIDROS** INNOVATION AS ENERGY

Company specialized in **dehumidification** and **humidification** of the air, since 2001 Hidros designs, develops, manufactures and tests condensation and dehumidification systems with refrigerant cycle, heat pumps and water chillers in different sizes and configurations. A know-how able to collect the benefits of experience, shaped in many years of presence on the market and built with a "problem solving" attitude.

Everyday Hidros keeps its mission alive thanks to the strength of ideas: the continuous development of new projects for special products not only meets the demands of the increasing competitive market, but also gives the company the opportunity to explore all the ways leading to innovation. In a liquid and strongly changing market, flexibility becomes a great value. This is the reason why today, Hidros is able to cover the production demand with a dehumidification capacity from 20 to 3050 litres/24h, cooling and heating capacities from 5 to 460 kW. At the same time it shows a great capacity to adapt the units to the actual needs of the customer. Hidros has a potential of expertise and enthusiasm that is conveyed through a large, flexible and specialised team, spread across many branches around the world.

## **THE ENVIRONMENT** EFFICIENCY AND SUSTAINABILITY

For Hidros, **Research and Development** into materials and products to enhance their efficiency and lower their environmental impact is fundamental to the group culture. The company is represented in the industry bodies that continually advise on climate change impact and are thus at the forefront of current knowledge. These efforts have resulted in Hidros launching new ranges of units that utilize materials and **refrigerants with the lowest Global warming impact** such as **R454B** a gas with very high efficiency and low GWP.

40 EXPORT COUNTRIES

- PRODUCTION SITES
- HIDROS OFFICES
- DISTRIBUTORS

# HIDROS

## WORLDWIDE

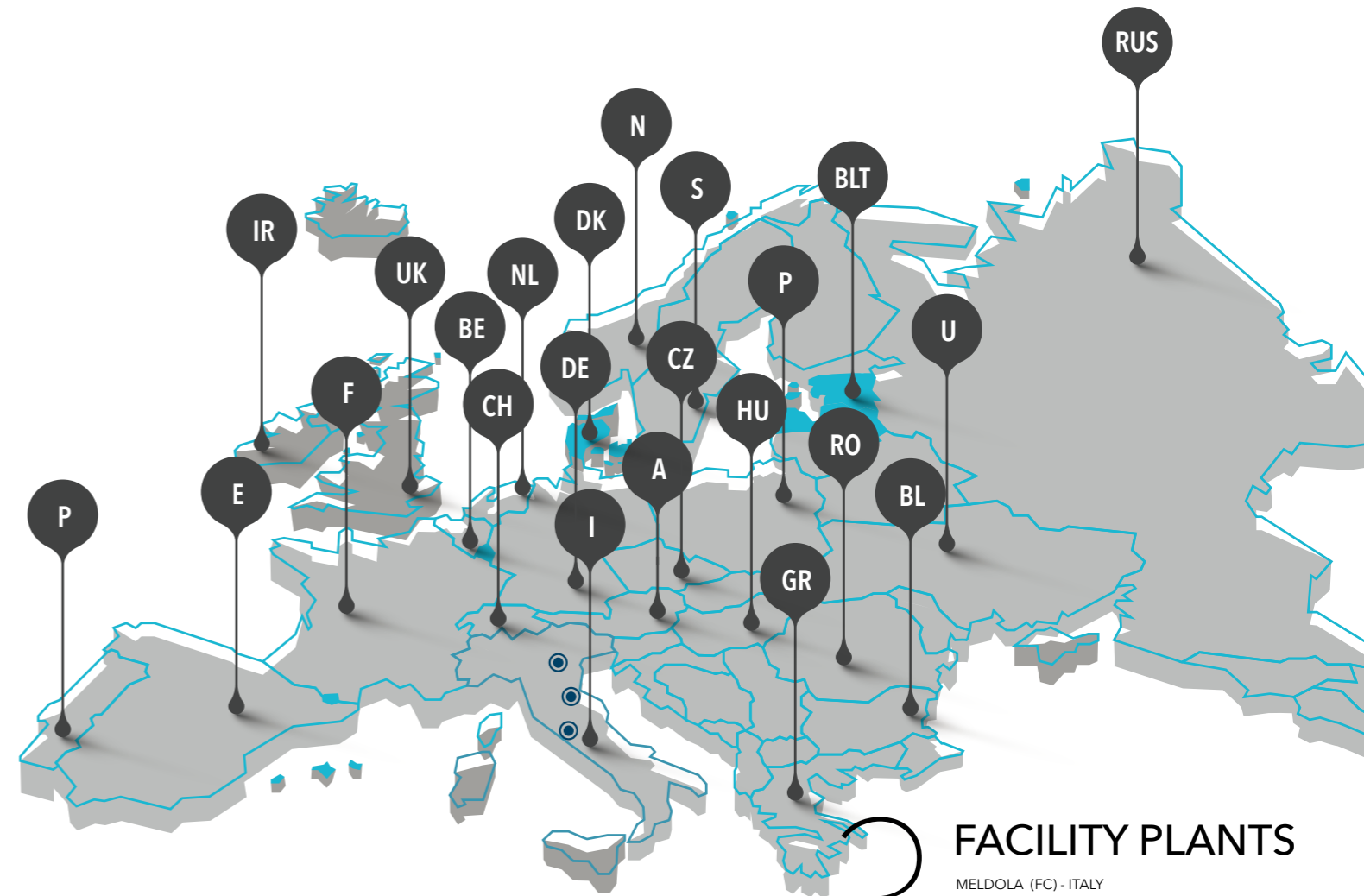

3 FACILITY PLANTS

- MELDOLA (FC) - ITALY
- PIOVE DI SACCO (PD) - ITALY
- MASSA MARTANA (PG) - ITALY

6 HIDROS SALE OFFICES

- ITALY
- GREAT BRITAIN
- UNITED ARAB EMIRATES
- NETHERLAND
- RUSSIA
- SPAIN

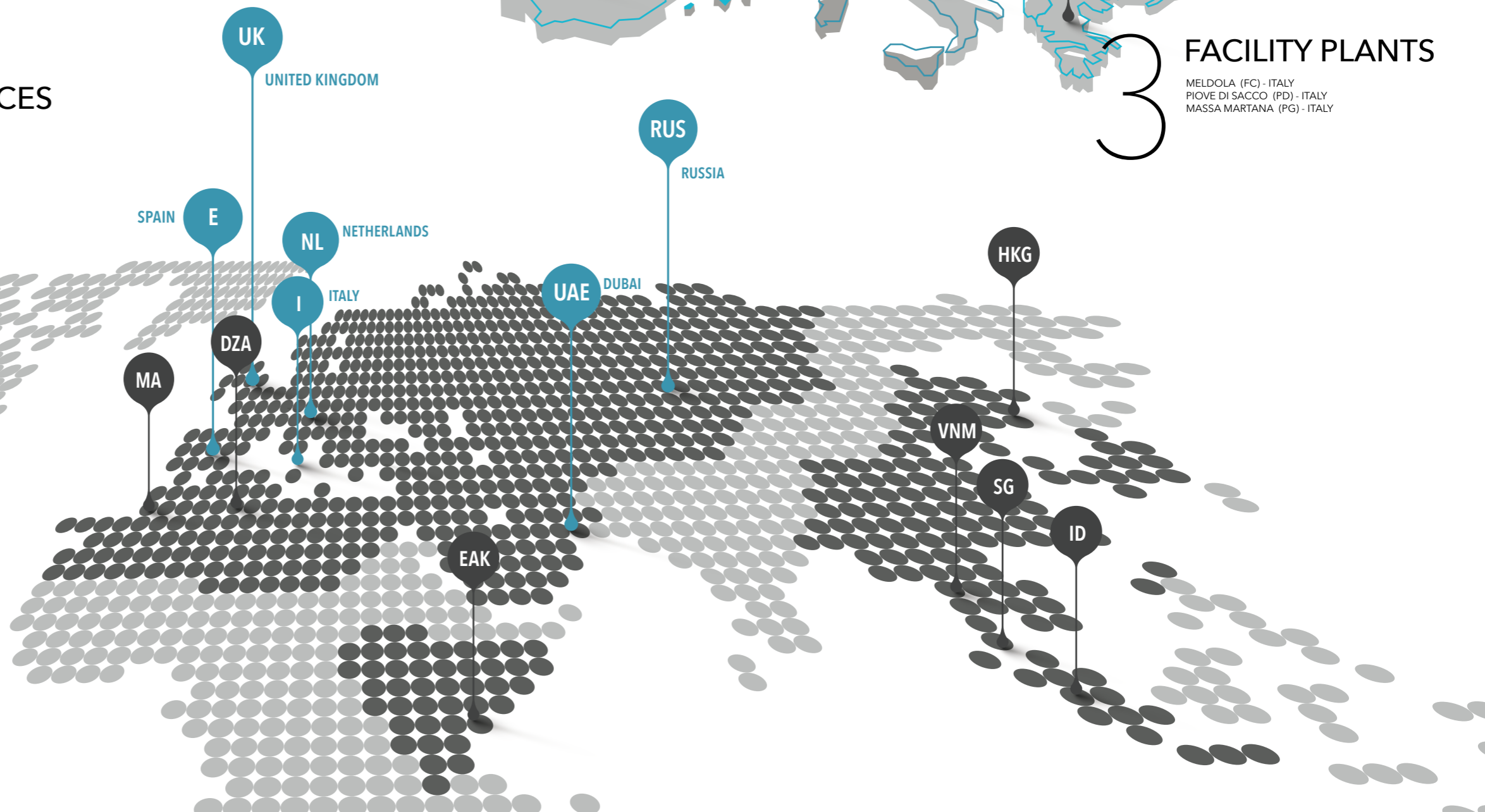

THE HIDROS

# LABS

## CLIMATIC ROOMS

HIDROS has **climatic rooms** and **testing stations** where units produced are subject to strict **functional** and **performance** tests, with the possibility of simulating the real design climatic conditions. A double hydronic circuit (hot and cold) allows to carry out **operation tests on all types** of units, both for IT Cooling and hydronic units, packaged, 2 or 4 pipes, air cooled, water cooled and split, up to a cooling capacity of 1500 kW.

It is possible, for our customers, to attend the functioning and performance test. Thanks to some webcams, it is possible to **remotely attend the test**.

## CHARACTERISTICS

The climatic room is an environment inside of which, by means of auxiliary and heat recovery systems, we create a **controlled microclimate** in terms of air **temperature** and **humidity**, where the heat transfer fluids are treated according to the specific characteristics of the unit.

The types of units that can be tested are **air or water cooled units**, available as **chiller** or **reversible heat pump** versions according to **EN14511** standard.

The operating limits of fluid temperature can vary between **-5°C** and **65°C**. The ambient temperature (inside the room) can reach a maximum of 52°C for summer operation and a minimum of -7°C for winter cycle.

# LEGEND



Air cooled



Water cooled



2-pipe unit



4-pipe unit



Indoor installation



Residential use



Industrial use



Swimming pool use



Units with a ground source



Remote condensing



Free cooling



High efficiency



Silenced version



Super-silenced version



Ultra-silenced version



Heating only



Reversible unit



Multipurpose Unit



Free cooling



Dehumidifying units



Outdoor temperature +43°C



Outdoor temperature -20°C



Domestic hot water +60°C



Domestic hot water +65°C



Domestic hot water +78°C



AC Fans



EC Fans



Centrifugal fan with AC motor



Centrifugal fan with EC motor



Plug-fan with AC motor



Plug-fan with EC motor



Scroll Compressors



Scroll inverter Compressors



E.V.I Scroll Compressors



Plate exchanger

# SERIES

# FEATURES

# REFRIGERANT

# HEAT PUMPS PERFORMANCE RANGE

0 kW 100 kW 200 kW 300 kW 400 kW 500 kW

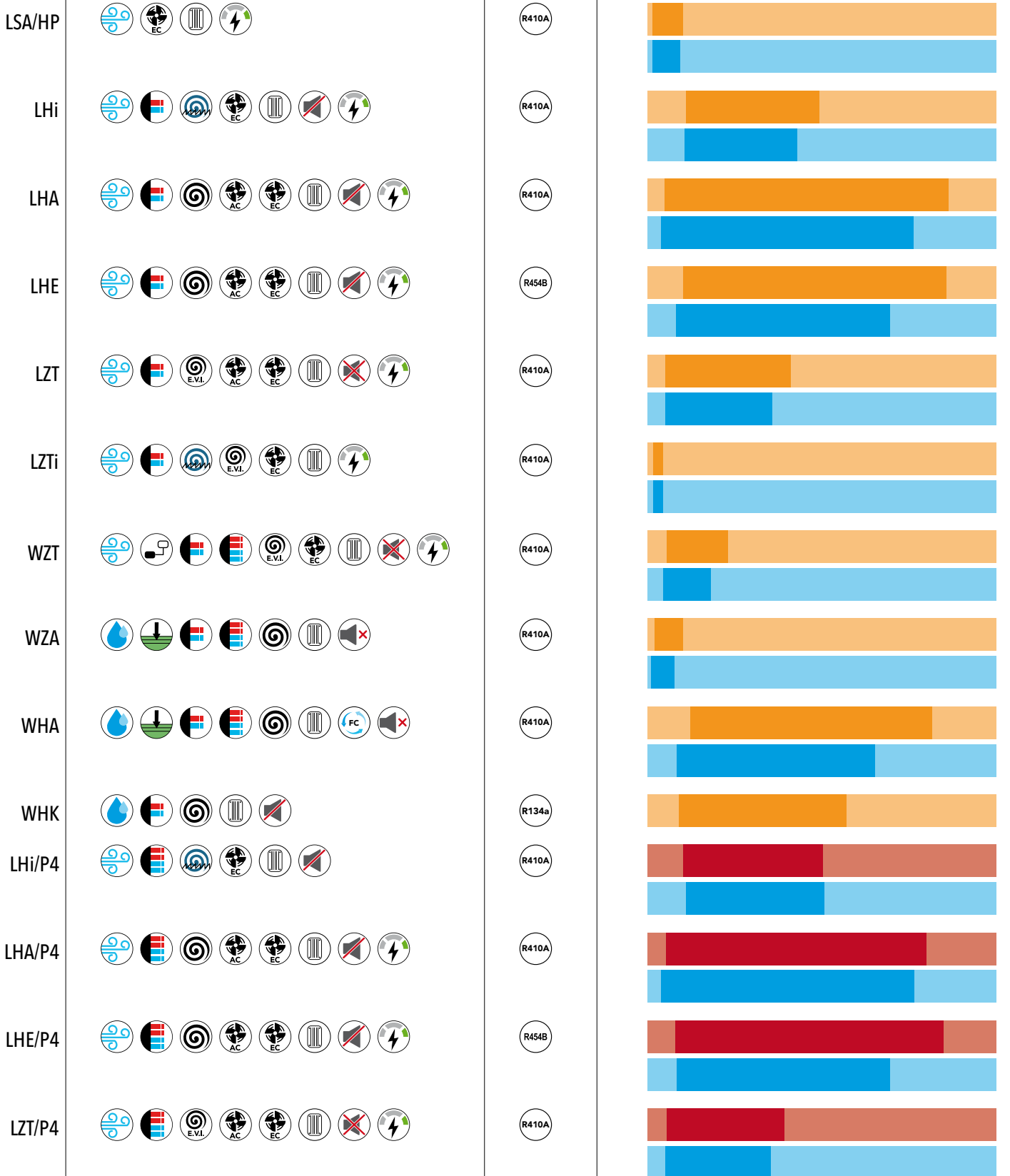



# SERIES

# FEATURES

## AIR FLOW

## DEHUMIDIFYING CAPACITY



# LSA/HP

## HIGH EFFICIENCY AIR TO WATER HEAT PUMPS

Heating capacity from 6 kW to 44 kW

R410A

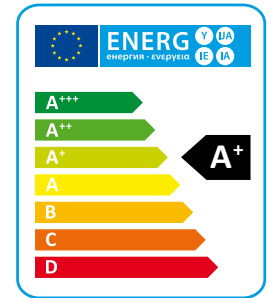

The LSA/HP water chiller range has been designed for small and medium residential and commercial applications.

They are suitable for generating chilled water at 7°C, commonly used in applications with fan coils and/or air handling units.

LSA/HP water chillers have high operating efficiencies and are quiet in operation.

Differing versions and a wide range of accessories, enable the optimal solution to be selected.

### VERSIONS

**HP** - Reversible version

## TECHNICAL DATA

LSA/HP		06	08	10	14	16	21	26	31	36	41
Cooling capacity (EN14511) <sup>(1)</sup>	kW	5,7	7,5	8,5	14,0	15,5	20,5	26,6	30,0	33,0	39,0
Total input power (EN14511) <sup>(1)</sup>	kW	1,9	2,5	2,8	4,7	5,7	6,8	8,8	10,5	11,8	13,8
EER (EN14511) <sup>(1)</sup>	W/W	3,0	3,0	3,0	2,9	2,7	3,0	3,0	2,9	2,8	2,8
Heating capacity (EN14511) <sup>(2)</sup>	kW	5,9	7,7	9,2	14,9	17,2	22,0	29,5	33,5	36,5	44,4
Total input power (EN14511) <sup>(2)</sup>	kW	1,5	2,0	2,3	3,9	4,3	5,2	6,8	8,2	9,0	10,7
COP (EN14511) <sup>(2)</sup>	W/W	3,9	3,9	4,0	3,8	4,0	4,3	4,3	4,1	4,1	4,2
Energy Class <sup>(3)</sup>		A+	A+	A+	A+	A+	A+	A+	A+	A+	A+
SCOP <sup>(3)</sup>	kWh/kWh	3,38	3,32	3,40	3,35	3,23	3,38	3,21	3,21	3,21	3,29
$\eta_{s,h}$ <sup>(3)</sup>	%	132,2	129,8	132,9	131,1	126,2	132,3	125,4	125,4	125,5	128,4
Power supply	V/Ph/Hz	230/1/50	230/1/50	230/1/50	400/3+N/50	400/3+N/50	400/3+N/50	400/3+N/50	400/3+N/50	400/3+N/50	400/3+N/50
Peak current	A	60,6	68,0	99,0	66,0	77,0	96,8	119,8	120,6	142,6	176,6
Max input current	A	13,4	18,1	23,0	13,3	17,0	17,8	23,8	27,6	33,6	36,6
Air flow	m <sup>3</sup> /h	2.800	3.350	3.150	7.200	7.000	8.500	8.500	10.800	10.800	10.800
Fans	n°/kW	1 x 0,12	1 x 0,2	1 x 0,2	2 x 0,2	2 x 0,2	2 x 0,2	2 x 0,2	2 x 0,5	2 x 0,5	2 x 0,5
Compressors / Circuits	n°/n°	1 / 1	1 / 1	1 / 1	1 / 1	1 / 1	1 / 1	1 / 1	1 / 1	1 / 1	1 / 1
Global warming potential (GWP)		2088	2088	2088	2088	2088	2088	2088	2088	2088	2088
Refrigerant charge	kg	3,0	4,2	3,7	3,7	5,0	7,3	8,0	6,5	6,5	8,0
Equivalent CO <sub>2</sub> charge	t	6,3	8,8	7,7	7,7	10,4	15,2	16,7	13,6	13,6	16,7
Sound power <sup>(4)</sup>	dB (A)	68	68	68	69	69	74	74	79	79	79
Sound pressure <sup>(5)</sup>	dB (A)	37	37	37	38	38	43	43	47	47	47
Water pump input power	kW	0,2	0,2	0,2	0,5	0,5	0,6	0,6	0,9	0,9	1,3
Pump available static pressure <sup>(1)</sup>	kPa	56,7	56,5	45,9	109,3	109,3	136,8	79,2	96,4	41,2	170,1
Water tank volume	l	30	30	30	45	45	45	45	135	135	135

Performances are referred to the following conditions:

(1)Cooling: ambient temperature 35°C; water temperature 12/7°C.

(2)Heating: ambient temperature 7°C (DB), 6°C (WB); water temperature 30/35°C.

(3) Average conditions, low temperature, variable - Reg EU 811/2013

(4) Sound power level in accordance with ISO 3744 (LS-Version).

(5) Sound pressure level at 10 mt from the unit in free field conditions in accordance with ISO 3744. (LS-Version).

## OPERATION LIMITS

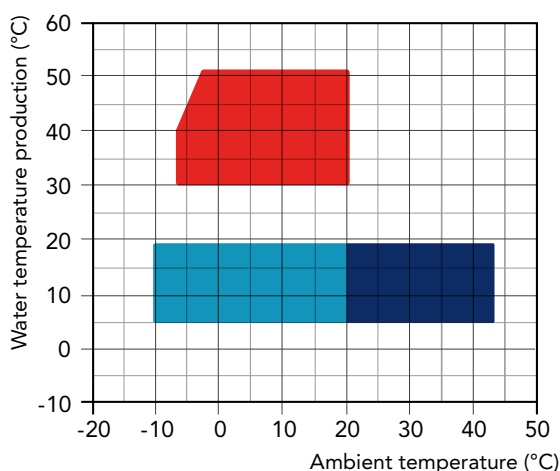

- Heating mode
- Cooling mode with cond. press. contr.
- Cooling mode without cond. press. contr.

## COMPONENTS

### FRAME

All LSA/HP units are made from hot-galvanised sheet steel, painted with polyurethane powder enamel and stoved at 180°C to provide maximum protection against corrosion. The frame is self-supporting with removable panels. All screws and rivets used are made from stainless steel. The standard colour of the units is RAL 9018.

### REFRIGERANT CIRCUIT

The refrigerant utilised is R410A. The refrigerant circuit is assembled using internationally recognised brand name components with all brazing and welding being performed in accordance with ISO 97/23. The refrigerant circuit includes: sight glass, filter drier, reversing valve (for reversible version only), one way valve (for reversible version only), liquid receiver (for reversible version only), Schraeder valves for maintenance and control and pressure safety device (for compliance with PED regulations).

### COMPRESSOR

For models 06 and 08, rotary type compressors are used. For all other models the compressors are of the scroll type. All compressors are fitted with a crankcase heater and each compressor has a klixon embedded in the motor winding for thermal overload protection. They are mounted in a separate compartment within the casing in order to isolate them from the condenser air stream. The crankcase heater is always energised when the compressor is in stand-by. Access to the compressor compartment is by removal of a front panel and, because they are isolated from the main airstream, maintenance of the compressors is possible whilst the unit is operating.

### CONDENSER

The condenser is made from 3/8" copper pipes and 0,1mm thick aluminium fins with the tubes being mechanically expanded into the aluminium fins in order to maximise heat transfer. Furthermore, the condenser design guarantees a low air side pressure drop thus enabling the use of low rotation speed (and hence low noise emission) fans. The condensers can be protected by a metallic filter that is available as an accessory.

### FANS

The fans are direct drive axial type with aluminium aerofoil blades, are statically and dynamically balanced and are supplied complete with a safety fan guard complying with the requirements of EN 60335. They are fixed to the unit frame via rubber anti-vibration mountings. The electric motors are 6 pole type rotating at approximately 900 rpm. The motors are fitted with integrated thermal overload protection and have a moisture protection rating of IP 54.

### EVAPORATORS

The evaporator is a braze welded, plate type heat exchanger, manufactured from AISI 316 stainless steel. Utilisation of this type of exchanger results in a massive reduction of the refrigerant charge of the unit compared to a traditional shell-in-tube evaporator. A further advantage is a reduction in the overall dimensions of the unit. The evaporators are factory insulated with flexible close cell material and can be fitted with an antifreeze heater (accessory). Each evaporator is fitted with a temperature sensor on the discharge water side for antifreeze protection.

### MICROPROCESSOR

All units are supplied with microprocessor controls loaded with ACTIVE auto-adaptive strategy. The microprocessor controls the following functions: control of the water temperature, antifreeze protection, compressor timing, compressor automatic starting sequence, alarm reset, volt free contact for remote general alarm, alarms and operation LED's. If required (available as an option), the microprocessor can be configured in order for it to connect to a site BMS system thus enabling remote control

and management. The Hidros technical department can discuss and evaluate, in conjunction with the customer, solutions using MODBUS protocols. The autoadaptive control system ACTIVE is an advanced strategy that continuously monitors the temperature of the inlet and outlet water thereby determining the variation of the building thermal load. By then adjusting the outlet water temperature set point the compressor start/stop cycle can be accurately controlled thus optimizing the unit efficiency and maximizing the operational life of the units component's. Use of ACTIVE auto-adaptive Control enables the minimum water content to be reduced from the traditional 12-15 l/kw to 5 l/kw. A further benefit of the reduced water requirement is that units can be used in installations without a buffer tank thereby reducing the space requirements, thermal losses and costs.

### ELECTRIC ENCLOSURE

The enclosure is manufactured in order to comply with the requirements of the electromagnetic compatibility standards CEE 2014/35 and 2014/30. Access to the enclosure is achieved by removing the front panel of the unit. The following components are supplied as standard on all units: main switch, thermal overloads (protection of pumps and fans), compressor fuses, control circuit automatic breakers, compressor contactors, fan contactors and pump contactors. The terminal board has volt free contacts for remote ON-OFF, summer / winter change over (reversible versions only) and general alarm. For all three phase units, a sequence relay that disables the power supply in the event that the phase sequence is incorrect (scroll compressors can be damaged if they rotate in the wrong direction), is fitted as standard.

### CONTROL AND PROTECTION DEVICES

All units are supplied with the following control and protection devices: Return water temperature sensor installed on the return water line from the building, antifreeze protection sensor installed on the outlet water temperature high pressure switch with manual reset, low pressure switch with automatic reset, high pressure safety valve, compressor thermal overload protection, fans thermal overload protection and flow switch.

## VERSIONS

### Reversible version (HP)

The reversible versions are provided with a 4 way reversing valve and are designed to produce hot water up to a temperature of 48°C. They are always supplied with a liquid receiver and a second thermostatic valve in order to optimize the efficiency of the refrigerant cycle in heating and in cooling. The microprocessor controls defrost automatically (when operating in low ambient conditions) and also the summer/winter change over.

## ACCESSORIES

LSA/HP		06	08	10	14	16	21	26	31	36	41
Main switch	-	-	-	-	●	●	●	●	●	●	●
Flow switch	-	●	●	●	●	●	●	●	●	●	●
Microprocessor control	-	●	●	●	●	●	●	●	●	●	●
General alarm digital output	-	●	●	●	●	●	●	●	●	●	●
Remote on/off digital input	-	●	●	●	●	●	●	●	●	●	●
Liquid line solenoid valve	VSLI	○	○	○	○	○	○	○	○	○	○
LS low noise version	LS00	○	○	○	○	○	○	○	○	○	○
Fans regulation by phase cut	DCCF	○	○	○	○	○	○	○	○	○	○
Rubber anti-vibration mounts	KAVG	○	○	○	○	○	○	○	○	○	○
Spring anti-vibration mounts	KAVM	○	○	○	○	○	○	○	○	○	○
Electronic soft starter	DSSE	○	○	○	○	○	○	○	○	○	○
Evaporator antifreeze heater (basic version only)	RAEV	○	○	○	○	○	○	○	○	○	○
Antifreeze Kit (only for A version)	RAES	○	○	○	○	○	○	○	○	○	○
Refrigerant circuit pressure gauges	MAML	○	○	○	○	○	○	○	○	○	○
Condensate discharge drip tray *	BRCA	○	○	○	○	○	○	○	○	○	○
Hydraulic kit pump + tank (A1ZZ)	A1ZZ	○	○	○	○	○	○	○	○	○	○
Hydraulic kit pump no tank(A1NT)	A1NT	○	○	○	○	○	○	○	○	○	○
Remote control panel	PCRL	○	○	○	○	○	○	○	○	○	○
Serial interface card RS485	INSE	○	○	○	○	○	○	○	○	○	○
Electronic thermostatic valve	VTEE	○	○	○	○	○	○	○	○	○	○

\* Condensate discharge drip tray with antifreeze heater (Only for versions HP)

● Standard, ○ Optional, - Not available.

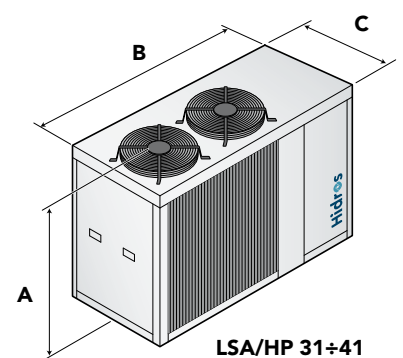
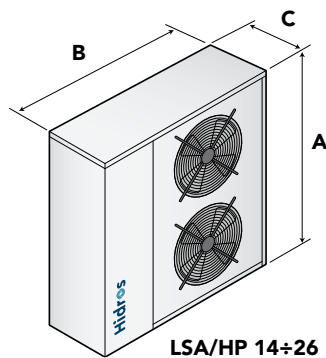
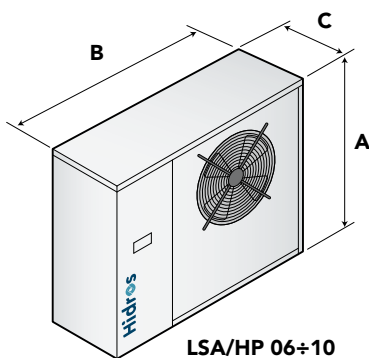

Mod.	A (mm)	B (mm)	C (mm)	kg
<b>06/06A</b>	989	1157	380	95/148
<b>08/08A</b>	989	1157	380	104/163
<b>10/10A</b>	989	1157	380	118/179
<b>14/14A</b>	1324	1245	423	127/207
<b>16/16A</b>	1324	1245	423	133/212

Mod.	A (mm)	B (mm)	C (mm)	kg
<b>21/21A</b>	1424	1508	473	188/267
<b>26/26A</b>	1424	1508	473	209/286
<b>31/31A</b>	1406	1910	950	330/440
<b>36/36A</b>	1406	1910	950	345/495
<b>41/41A</b>	1406	1910	950	360/520

# LHi

## HIGH EFFICIENCY AIR TO WATER HEAT PUMPS WITH INVERTER COMPRESSOR

Heating capacity from 51 kW to 270 kW

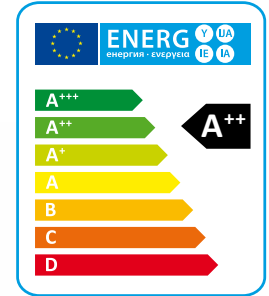

The LHi series high efficiency air/water heat pumps are particularly suitable for applications with radiant panel heating systems or for those applications where maximum efficiency in heating mode is required.

The units have been specifically designed to have the best efficiency in heating mode, they can operate up to outdoor temperatures of -20°C and produce water up to a temperature of 60°C.

All models are also equipped with reverse cycle valve for winter defrosting function; the HH versions are designed for hot water production only and are suitable for tax deductions in countries where there are specific regulations for the use of heat pumps as heat generators.

The RV versions are capable of producing chilled water. The XL versions also have an extremely low noise level thanks to the use of a special floating vibration dampening system that allows a noise reduction of about 6-8 dB(A) (optional).

### VERSIONS

- HH** Heating only.
- RV** Reversible heating/cooling.
- SE** Standard efficiency, EC fans.
- LS** Low noise.
- XL** Super low noise.
- P2U** 2 pipe systems without domestic hot water production.
- P2S** 2 pipe systems with domestic hot water production by external 3 way valve.

## TECHNICAL DATA

Heating only version (HH)

SE/LS/HH - P2S/P2U		532	632	742	862	912	1052	1222	1534	1654	1854	1964	2254	2554
Heating capacity (EN14511) <sup>(1)</sup>	kW	53,3	61,8	74,2	85,1	90,9	102,5	118,3	129,0	145,3	165,2	188,7	223,4	269,6
Total input power (EN14511) <sup>(1)</sup>	kW	13,2	14,7	18,7	20,0	22,1	24,9	28,5	31,2	34,0	39,1	44,8	55,1	65,8
COP (EN14511) <sup>(1)</sup>	W/W	4,04	4,19	3,97	4,25	4,11	4,12	4,15	4,14	4,27	4,23	4,21	4,06	4,10
Energy Class <sup>(2)</sup>		A++	A++	A++	A++	A++	A++	A++	A++	A++	A++	A++	A++	A++
SCOP <sup>(2)</sup>	kWh/kWh	3,88	3,93	3,90	3,98	3,92	3,93	3,88	3,95	3,93	4,00	3,90	3,88	3,88
$\eta_{s,h}$ <sup>(2)</sup>	%	152	154	153	156	154	154	152	155	154	157	153	152	152
Sound power level <sup>(3)</sup>	dB (A)	81	81	83	83	83	84	85	86	87	87	87	89	89
Sound pressure level <sup>(4)</sup>	dB (A)	49	49	51	51	51	52	53	54	55	55	55	57	57
Power supply	V/Ph/Hz	400/3/50	400/3/50	400/3/50	400/3/50	400/3/50	400/3/50	400/3/50	400/3/50	400/3/50	400/3/50	400/3/50	400/3/50	400/3/50
Compressors / Circuits	n° / n°	2 / 1	2 / 1	2 / 1	2 / 1	2 / 1	2 / 1	2 / 1	4 / 2	4 / 2	4 / 2	4 / 2	4 / 2	4 / 2
Fans	n°	2	2	2	3	3	3	4	2	3	3	3	4	4
Refrigerant		R410A	R410A	R410A	R410A	R410A	R410A	R410A	R410A	R410A	R410A	R410A	R410A	R410A
Refrigerant charge	kg	10,4	14,7	14,7	17,5	17,5	22,3	22,7	32,6	39,8	39,8	45,5	50,9	59,0
Global warming potential (GWP)		2088	2088	2088	2088	2088	2088	2088	2088	2088	2088	2088	2088	2088
Equivalent CO <sub>2</sub> charge	t	21,8	30,7	30,7	36,5	36,5	46,5	47,4	68,0	83,2	83,2	95,0	106,2	123,1
Water tank volume	l	140	300	300	500	500	500	500	300	500	500	500	500	500

SE/XL/HH - P2S/P2U		532	632	742	862	912	1052	1222	1534	1654	1854	1964	2254	2554
Heating capacity (EN14511) <sup>(1)</sup>	kW	51,8	59,4	77,1	82,9	87,8	101,9	114,4	126,9	142,2	163,6	184,6	224,7	267,2
Total input power (EN14511) <sup>(1)</sup>	kW	12,8	14,3	18,6	19,8	21,5	24,2	27,7	30,1	32,3	37,7	42,9	53,3	63,8
COP (EN14511) <sup>(1)</sup>	W/W	4,04	4,15	4,15	4,20	4,08	4,21	4,13	4,22	4,41	4,35	4,31	4,22	4,19
Energy Class <sup>(2)</sup>		A++	A++	A++	A++	A++	A++	A++	A++	A++	A++	A++	A++	A++
SCOP <sup>(2)</sup>	kWh/kWh	3,95	4,10	4,08	4,13	4,10	4,03	4,00	4,18	4,28	4,25	4,18	4,15	4,13
$\eta_{s,h}$ <sup>(2)</sup>	%	155	161	160	162	161	158	157	164	168	167	164	163	162
Sound power level <sup>(3)</sup>	dB (A)	76	77	78	78	79	79	80	80	80	80	82	83	84
Sound pressure level <sup>(4)</sup>	dB (A)	44	45	46	46	47	47	48	48	48	48	50	51	52
Power supply	V/Ph/Hz	400/3/50	400/3/50	400/3/50	400/3/50	400/3/50	400/3/50	400/3/50	400/3/50	400/3/50	400/3/50	400/3/50	400/3/50	400/3/50
Compressors / Circuits	n° / n°	2 / 1	2 / 1	2 / 1	2 / 1	2 / 1	2 / 1	2 / 1	4 / 2	4 / 2	4 / 2	4 / 2	4 / 2	4 / 2
Fans	n°	2	2	2	3	3	3	4	2	3	3	3	4	4
Refrigerant		R410A	R410A	R410A	R410A	R410A	R410A	R410A	R410A	R410A	R410A	R410A	R410A	R410A
Refrigerant charge	kg	10,4	14,7	16,3	17,5	17,5	22,3	22,7	32,6	39,8	39,8	32,5	50,9	59,0
Global warming potential (GWP)		2088	2088	2088	2088	2088	2088	2088	2088	2088	2088	2088	2088	2088
Equivalent CO <sub>2</sub> charge	t	21,8	30,7	34,1	36,5	36,5	46,5	47,4	68,0	83,2	83,2	67,8	106,2	123,1
Water tank volume	l	140	300	300	500	500	500	500	300	500	500	500	500	500

Performances are referred to the following conditions:

(1) Heating: Ambient temperature 7°C DB, 6°C WB, water temperature 30/35°C.

(2) Average conditions, low temperature, variable - Reg EU 811/2013

(3) Sound power level in accordance with ISO 3744.

(4) Sound pressure level at 10 mt from the unit in free field conditions in accordance with ISO 3744.

Reversible heating/cooling version (RV)

SE/LS/RV - P2S/P2U		532	632	742	862	912	1052	1222	1534	1654	1854	1964	2254	2554
Heating capacity (EN14511) <sup>(1)</sup>	kW	53,3	61,8	74,2	85,1	90,9	102,5	118,3	129,0	145,3	165,2	188,7	223,4	269,6
Total input power (EN14511) <sup>(1)</sup>	kW	13,2	14,7	18,7	20,0	22,1	24,9	28,5	31,2	34,0	39,1	44,8	55,1	65,8
COP (EN14511) <sup>(1)</sup>	W/W	4,04	4,19	3,97	4,25	4,11	4,12	4,15	4,14	4,27	4,23	4,21	4,06	4,10
Energy Class <sup>(2)</sup>		A++	A++	A++	A++	A++	A++	A++	A++	A++	A++	A++	A++	A++
SCOP <sup>(2)</sup>	kWh/kWh	3,88	3,93	3,90	3,98	3,92	3,93	3,88	3,95	3,93	4,00	3,90	3,88	3,88
$\eta_{s,h}$ <sup>(2)</sup>	%	152	154	153	156	154	154	152	155	154	157	153	152	152
Cooling capacity (EN14511) <sup>(3)</sup>	kW	49,32	57,71	68,9	78,87	83,19	95,32	109,3	112,8	129,4	146,3	162,5	197,4	230,6
Total input power (EN14511) <sup>(3)</sup>	kW	16,42	18,47	24,48	25,78	28,18	31,81	36,3	40,3	42,6	50,2	57,0	69,5	84,6
EER (EN14511) <sup>(3)</sup>	W/W	3,00	3,12	2,81	3,06	2,95	3,00	3,01	2,80	3,04	2,91	2,85	2,84	2,72
Sound power level <sup>(4)</sup>	dB (A)	81	81	83	83	83	84	85	86	87	87	87	89	89
Sound pressure level <sup>(5)</sup>	dB (A)	49	49	51	51	51	52	53	54	55	55	55	57	57
Power supply	V/Ph/Hz	400/3/50	400/3/50	400/3/50	400/3/50	400/3/50	400/3/50	400/3/50	400/3/50	400/3/50	400/3/50	400/3/50	400/3/50	400/3/50
Compressors / Circuits	n° / n°	2 / 1	2 / 1	2 / 1	2 / 1	2 / 1	2 / 1	2 / 1	4 / 2	4 / 2	4 / 2	4 / 2	4 / 2	4 / 2
Fans	n°	2	2	2	3	3	3	4	2	3	3	3	4	4
Refrigerant		R410A	R410A	R410A	R410A	R410A	R410A	R410A	R410A	R410A	R410A	R410A	R410A	R410A
Refrigerant charge	kg	10,4	14,7	14,7	17,5	17,5	22,3	22,7	32,6	39,8	39,8	45,5	50,9	59,0
Global warming potential (GWP)		2088	2088	2088	2088	2088	2088	2088	2088	2088	2088	2088	2088	2088
Equivalent CO <sub>2</sub> charge	t	21,8	30,7	30,7	36,5	36,5	46,5	47,4	68,0	83,2	83,2	95,0	106,2	123,1
Water tank volume	l	140	300	300	500	500	500	500	300	500	500	500	500	500

Performances are referred to the following conditions:

(1) Heating: Ambient temperature 7°C DB, 6°C WB, water temperature 30/35°C.

(2) Average conditions, low temperature, variable - Reg EU 811/2013.

(3) Cooling: ambient air temperature 35°C, evaporator water temperature in/out 12/7 °C.

(4) Sound power level in accordance with ISO 3744.

(5) Sound pressure level at 10 mt from the unit in free field conditions in accordance with ISO 3744.



SE/XL/RV - P2S/P2U		532	632	742	862	912	1052	1222	1534	1654	1854	1964	2254	2554
Heating capacity (EN14511) <sup>(1)</sup>	kW	51,8	59,4	77,1	82,9	87,8	101,9	114,4	126,9	142,2	163,6	184,6	224,7	267,2
Total input power (EN14511) <sup>(1)</sup>	kW	12,8	14,3	18,6	19,8	21,5	24,2	27,7	30,1	32,3	37,7	42,9	53,3	63,8
COP (EN14511) <sup>(1)</sup>	W/W	4,04	4,15	4,15	4,20	4,08	4,21	4,13	4,22	4,41	4,35	4,31	4,22	4,19
Energy Class <sup>(2)</sup>		A++	A++	A++	A++	A++	A++	A++	A++	A++	A++	A++	A++	A++
SCOP <sup>(2)</sup>	kWh/kWh	3,95	4,10	4,08	4,13	4,10	4,03	4,00	4,18	4,28	4,25	4,18	4,15	4,13
$\eta_{s,h}$ <sup>(2)</sup>	%	155	161	160	162	161	158	157	164	168	167	164	163	162
Cooling capacity (EN14511) <sup>(3)</sup>	kW	48,0	55,9	70,4	76,4	80,4	91,9	105,7	109,4	124,9	140,1	154,6	198,5	231,8
Total input power (EN14511) <sup>(3)</sup>	kW	16,3	18,4	22,7	25,6	28,1	32,1	36,2	38,9	40,8	49,4	56,0	62,9	77,9
EER (EN14511) <sup>(3)</sup>	W/W	2,86	2,96	3,00	2,90	2,79	2,80	2,84	2,68	2,93	2,73	2,67	2,97	2,83
Sound power level <sup>(4)</sup>	dB (A)	76	77	78	78	79	79	80	80	80	80	82	83	84
Sound pressure level <sup>(5)</sup>	dB (A)	44	45	46	46	47	47	48	48	48	48	50	51	52
Power supply	V/Ph/Hz	400/3/50	400/3/50	400/3/50	400/3/50	400/3/50	400/3/50	400/3/50	400/3/50	400/3/50	400/3/50	400/3/50	400/3/50	400/3/50
Compressors / Circuits	n° / n°	2 / 1	2 / 1	2 / 1	2 / 1	2 / 1	2 / 1	2 / 1	4 / 2	4 / 2	4 / 2	4 / 2	4 / 2	4 / 2
Fans	n°	2	2	2	3	3	3	4	2	3	3	3	4	4
Refrigerant		R410A	R410A	R410A	R410A	R410A	R410A	R410A	R410A	R410A	R410A	R410A	R410A	R410A
Refrigerant charge	kg	10,4	14,7	16,3	17,5	17,5	22,3	22,7	32,6	39,8	39,8	32,5	50,9	59,0
Global warming potential (GWP)		2088	2088	2088	2088	2088	2088	2088	2088	2088	2088	2088	2088	2088
Equivalent CO <sub>2</sub> charge	t	21,8	30,7	34,1	36,5	36,5	46,5	47,4	68,0	83,2	83,2	67,8	106,2	123,1
Water tank volume	l	140	300	300	500	500	500	500	300	500	500	500	500	500

Performances are referred to the following conditions:

(1) Heating: Ambient temperature 7°C DB, 6°C WB, water temperature 30/35°C.

(2) Average conditions, low temperature, variable - Reg EU 811/2013.

(3) Cooling: ambient air temperature 35°C, evaporator water temperature in/out 12/7 °C.

(4) Sound power level in accordance with ISO 3744.

(5) Sound pressure level at 10 mt from the unit in free field conditions in accordance with ISO 3744.

## COMPONENTS

### FRAME

All units are made from hot-galvanised sheet steel, painted with polyurethane powder enamel and stoved at 180°C to provide maximum protection against corrosion. The frame is self-supporting with removable panels. All screws and rivets used are made from stainless steel. The standard colour of the units is RAL9018.

### REFRIGERANT CIRCUIT

The refrigerant utilised is R410A. The refrigerant circuit is assembled using internationally recognised brand name components with all brazing and welding being performed in accordance with ISO 97/23. The refrigerant circuit includes: sight glass, filter drier, two thermal expansion valves (one for cooling mode, one for heating mode) with external equalizer, 4 way reversing valve, check valves, liquid receiver, Schrader valves for maintenance and control, pressure safety device (for compliance with PED regulations).

### COMPRESSORS

The compressors used are three-phase scroll type BPM (brushless permanent magnet) high efficiency, controlled by an Inverter, supplied with a specific design that increases the efficiency of the refrigerant cycle in very low ambient temperature conditions. All sizes use compressors in tandem configuration, and are all optimized for heat pump applications for high seasonal efficiency (SCOP).

The compressors are all supplied with electrical resistance and thermal overload protection. They are all mounted in a dedicated compartment to keep them separated from the airflow. The electric heater is always powered when the compressor is in stand by mode. Maintenance is possible through the front panel of the unit which allows to reach the compressors even when the machine is running.

### SOURCE HEAT EXCHANGER

The source heat exchanger is made from copper pipes and aluminium fins. Dimensioning of the copper pipes and the aluminium fins is optimized in order to obtain excellent performance. The tubes are mechanically expanded into the fins in order to maximise heat transfer. Furthermore, the design guarantees a low air side pressure drop thus enabling the use of low rotation speed (and hence low noise) fans. All heat exchangers are supplied standard with fins hydrophilic coating.

### HIGH EFFICIENCY E.C. AXIAL FANS (VECE)

High efficiency E.C. axial fans, supplied with Brushless DC electric motors electronically commutated (E.C. motors) able to grant the highest energy efficiency class (EFF1), according to the latest EU specifications, with the result of substantial energy consumption reduction for ventilation and noise reduction thanks to the new ultra efficient blade profiling. The fans are statically and dynamically balanced and supplied complete with a safety fan guard complying with the requirements of EN 60335. The fans are installed using a special steel profiled beam who minimize all vibrations and noise emitted. The average nominal rotation speed is 700 rpm. All units are fitted with a pressure transducer for the control of the evaporation/condensation pressure. All electric motors are The motors are fitted with integrated thermal overload protection rating IP54.

The motors are fitted with integrated thermal overload protection and have a moisture protection rating of IP 54.

### MICROPROCESSORS

All units are supplied as standard complete with control panel. The microprocessor controls the following functions: control of the water temperature, antifreeze protection, compressor timing, compressor automatic starting sequence (For multiple compressors), alarm reset.

The control panel is supplied with display showing all operation-

al icons. The microprocessor is set for automatic defrost (when operating in severe ambient conditions) and for summer/ winter change over (only for RV versions).

The control also manages the anti-legionella program, the integration with other heating sources (electric heaters, boilers, solar panels etc), the operation of a three port modulating valve (for diverting to DHW or heating) and both the heating circuit pump and the domestic hot water circuit pump. All units are set up for connection to a site BMS system thus enabling remote control and management.

### ELECTRIC ENCLOSURE

The enclosure is manufactured in order to comply with the requirements of the electromagnetic compatibility standards CEE EN60204. Access to electrical cabinet in quick and easy thanks to hinged panels. The following components are supplied as standard on all units: main switch, a sequence relay that disables the power supply in the event that the phase sequence is incorrect (scroll compressors can be damaged if they rotate in the wrong direction), thermal overloads (protection of pumps and fans), compressor fuses, control circuit automatic breakers, compressor contactors, fan contactors and pump contactors. The terminal board has volt free contacts for remote ON-OFF, Summer/ winter change over (heat pumps only) and general alarm.

### CONTROL AND PROTECTION DEVICES

All units are supplied with the following controls and protections: user water return temperature sensor, antifreeze protection temperature sensor installed on users water output, domestic hot water supply and return temperature sensors (only versions P2S), high pressure and low pressure automatic reset, compressor thermal protection, air fan, thermal protection, pressure transducer (used to optimize the defrost cycle and to adjust the fan speed depending on ambient conditions), flow switch. All units are also fitted with a temperature probe sensor with "Energy Saving" function, supplied in a separate plastic box, which can be used to stop the pump use during periods of stand-by, when the water temperature reaches the set point. Doing this the power consumption of the unit is strongly reduced.

### ELECTRONIC EXPANSION VALVE (VTEE)

The use of the electronic thermostatic valve is particularly suitable for units operating under very variable load conditions. The electronic expansion valve enables the maximum possible efficiency to be achieved by maximizing the evaporator heat exchange, minimizing the reaction time to load variations and optimizing the superheat. The use of the electronic thermostatic valve is particularly suitable for units operating under very variable load conditions.

## VERSIONS

### P2U Version

This is a two pipe version that can produce hot water for heating (HH heating only) and hot or cold water in the RV version. The RV is used with two pipe water based change-over systems. It is not able to produce domestic hot water.

### P2S Version

This is a two pipe version that can, in addition to producing hot water for heating (HH version) and hot and cold water in the RV version can also generate domestic hot water. The controller has dual heating set points (heating and DHW) and can also control a three port diverting valve that directs the DHW to the cylinder. DHW production has priority irrespective of the mode of operation of the unit. The unit is normally used with two pipe water based change-over systems.

**HH Version**

HH heating only versions are available in the P2U and P2S configuration only.

**RV Version**

This version uses 2 hydraulic connections and is able to produce hot water in winter and cold water in summer. The unit is combined with a 2-pipe system.

**SE Version**

Standard efficiency version, according to current standard. Unit equipped with EC fans.

**LS Version**

This version includes the complete acoustic insulation of the unit with compressor jackets and insulating material made with high density media and the interposition of heavy bitumen layer.

**XL Super low noise version**

All XL super silenced units are supplied equipped with a special vibration-damping system consisting of a floating basement placed upon the unit's frame, through the interposition of high-damping steel springs.

The compressors are housed on this floating base and are in turn fixed by means of rubber anti-vibration supports.

The enclosure is manufactured from galvanized steel sandwich panels that have a micro-perforated inner skin and a core of 30 mm thick, high density (25 kg/m<sup>3</sup>) soundproofing mat. The entire arrangement provides a double damping system and acoustic attenuation. The compressor refrigerant pipes are connected to the refrigerant circuit through "anaconda" flexible connections. Flexible connections are also used on the water pipework within the unit. The combination of these systems results in an overall noise reduction in the region of 6-8 dB(A) compared to units in standard configuration.

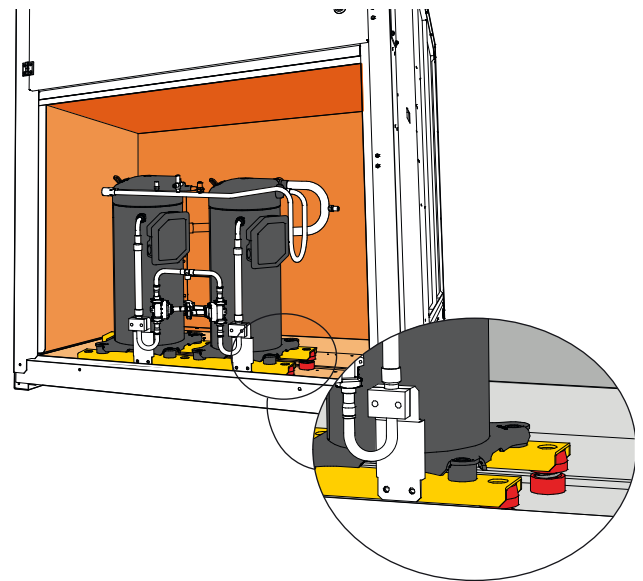
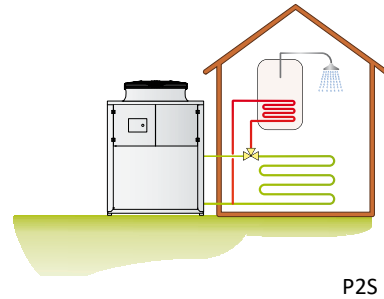
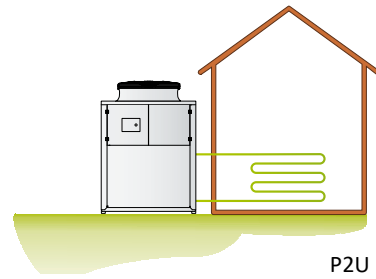

**OPERATION LIMITS**

**(SE versions)**

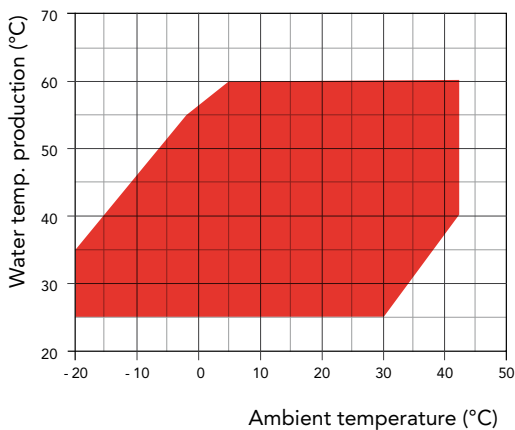

**(RV versions Only)**

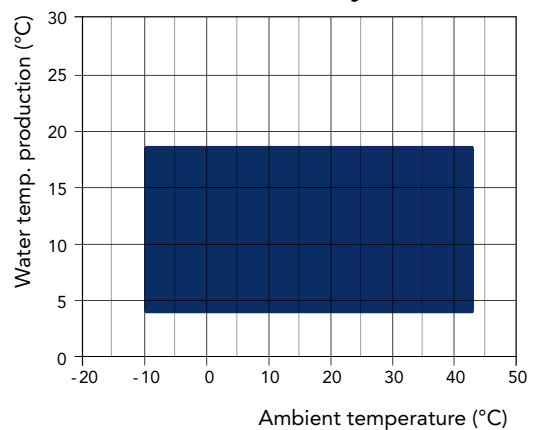

- Heating mode
- Cooling mode

## ACCESSORIES

LHi SE/HH-RV	P2S/P2U	532	632	742	862	912	1052	1222
Flow switch		●	●	●	●	●	●	●
"Floating frame" Technology - XL Version		●	●	●	●	●	●	●
E.C. fans - SE versions	VECE	●	●	●	●	●	●	●
Condensate discharge drip tray with antifreeze heater	BRCA	○	○	○	○	○	○	○
Antifreeze kit for 2 pipe units	RAEV2	○	○	○	○	○	○	○
Electronic soft starter	DSSE	○	○	○	○	○	○	○
Serial interface card RS485	INSE	●	●	●	●	●	●	●
Rubber anti-vibration mountings	KAVG	○	○	○	○	○	○	○
Remote control panel	PCRL	○	○	○	○	○	○	○
Electronic expansion valve	VTEE	●	●	●	●	●	●	●
Power factor correction system	RICO	○	○	○	○	○	○	○
Power factor correction system with soft starter	RICSS	○	○	○	○	○	○	○
Spring vibration dampers	KAVM	○	○	○	○	○	○	○
Coil protection grid	GBPE	○	○	○	○	○	○	○
Shut-off valve on compressor discharging side	RDCCO	○	○	○	○	○	○	○
Shut-off valve on compressor suction side	RHCO	○	○	○	○	○	○	○
Hydraulic kit with one inverter pump	A1VSU	○	○	○	○	○	○	○
Hydraulic kit with one pump without tank	A1NTU	○	○	○	○	○	○	○
Hydraulic kit with one higher available pressure pump	A1HPU	○	○	○	○	○	○	○
Hydraulic kit with two pumps without tank	A2NTU	○	○	○	○	○	○	○
Hydraulic kit with tank and one inverter pump	A1VVU	○	○	○	○	○	○	○
Hydraulic kit with one pump with tank	A1ZZU	○	○	○	○	○	○	○
Hydraulic kit with tank and one higher available pressure pump	A1HHU	○	○	○	○	○	○	○
Hydraulic kit with two pumps with tank	A2ZZU	○	○	○	○	○	○	○
Buffer tank and pump for internal loop	BUF4A	○	○	○	○	○	○	○
Antifreeze kit in combination with A1VSU / A1NTU / A1HPU *	KPU1	○	○	○	○	○	○	○
Antifreeze kit in combination with A2NTU *	KPU2	○	○	○	○	○	○	○
Antifreeze kit in combination with pump and buffer tank *	KPSU1	○	○	○	○	○	○	○
Antifreeze kit in combination with pumps and buffer tank *	KPSU2	○	○	○	○	○	○	○

\* Includes accessory RAEV2

● Standard ○ Optional – Not available

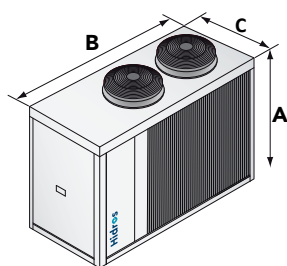

**SE/LS 532**  
**SE/XL 532**

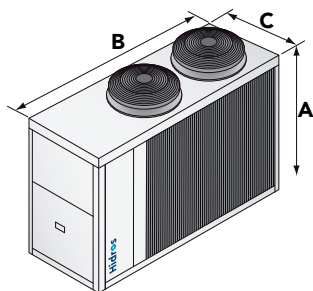

**SE/LS 632 - 742**  
**SE/XL 632**

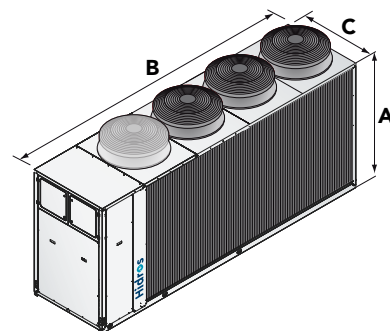

**SE/LS 862 - 912 - 1052 - 1222**  
**SE/XL 742 - 862 - 912 - 1052 - 1222**

		532	632	742	862	912	1052	1222
A (mm)	SE/LS	1690	1840	1840	1840	1840	1840	1840
B (mm)	SE/LS	2400	2905	2905	3905	3905	3905	3905
C (mm)	SE/LS	1145	1145	1145	1145	1145	1145	1145
kg	SE/LS	810	940	950	970	1270	1360	1410
A (mm)	SE/XL	1690	1840	1840	1840	1840	1840	1840
B (mm)	SE/XL	2400	2905	3905	3905	3905	3905	3905
C (mm)	SE/XL	1145	1145	1145	1145	1145	1145	1145
kg	SE/XL	830	960	970	990	1290	1380	1430

LHi SE/HH-RV	P2S/P2U	1534	1654	1854	1964	2254	2554
Flow switch		●	●	●	●	●	●
"Floating frame" Technology - XL Version		●	●	●	●	●	●
E.C. fans - SE versions	VECE	●	●	●	●	●	●
Condensate discharge drip tray with antifreeze heater	BRCA	○	○	○	○	○	○
Antifreeze kit for 2 pipe units	RAEV2	○	○	○	○	○	○
Electronic soft starter	DSSE	○	○	○	○	○	○
Serial interface card RS485	INSE	●	●	●	●	●	●
Rubber anti-vibration mountings	KAVG	○	○	○	○	○	○
Remote control panel	PCRL	○	○	○	○	○	○
Electronic expansion valve	VTEE	●	●	●	●	●	●
Power factor correction system	RICO	○	○	○	○	○	○
Power factor correction system with soft starter	RICSS	○	○	○	○	○	○
Spring vibration dampers	KAVM	○	○	○	○	○	○
Coil protection grid	GBPE	○	○	○	○	○	○
Shut-off valve on compressor discharging side	RDCO	○	○	○	○	○	○
Shut-off valve on compressor suction side	RHCO	○	○	○	○	○	○
Hydraulic kit with one inverter pump	A1VSU	○	○	○	○	○	○
Hydraulic kit with one pump without tank	A1NTU	○	○	○	○	○	○
Hydraulic kit with one higher available pressure pump	A1HPU	○	○	○	○	○	○
Hydraulic kit with two pumps without tank	A2NTU	○	○	○	○	○	○
Hydraulic kit with tank and one inverter pump	A1VVU	○	○	○	○	○	○
Hydraulic kit with one pump with tank	A1ZZU	○	○	○	○	○	○
Hydraulic kit with tank and one one higher available pressure pump	A1HHU	○	○	○	○	○	○
Hydraulic kit with two pumps with tank	A2ZZU	○	○	○	○	○	○
Buffer tank and pump for internal loop	BUF4A	○	○	○	○	○	○
Antifreeze kit in combination with A1VSU / A1NTU / A1HPU *	KPU1	○	○	○	○	○	○
Antifreeze kit in combination with A2NTU *	KPU2	○	○	○	○	○	○
Antifreeze kit in combination with pump and buffer tank *	KPSU1	○	○	○	○	○	○
Antifreeze kit in combination with pumps and buffer tank *	KPSU2	○	○	○	○	○	○

\* Includes accessory RAEV2

● Standard ○ Optional – Not available

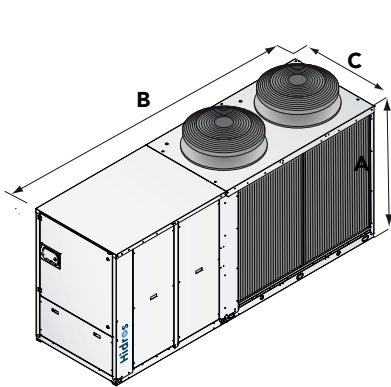

**SE/LS 1534**  
**SE/XL 1534**

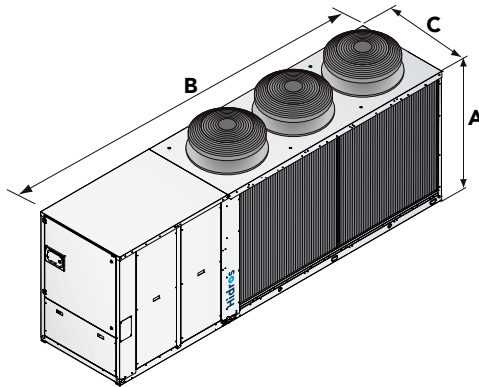

**SE/LS 1654 - 1854 - 1964**  
**SE/XL 1654 - 1854 - 1964**

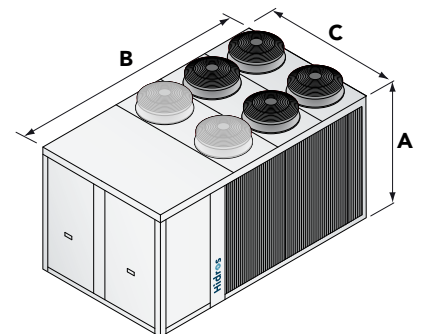

**SE/LS 2254 - 2554**  
**SE/XL 2254 - 2554**

		1534	1654	1854	1964	2254	2554
A (mm)	SE/LS	1890	1890	1890	1890	2350	2350
B (mm)	SE/LS	3695	4695	4695	4695	4205	4205
C (mm)	SE/LS	1145	1145	1145	1145	2190	2190
kg	SE/LS	1460	1810	1830	2130	2680	2720
A (mm)	SE/XL	1890	1890	1890	1890	2350	2350
B (mm)	SE/XL	3695	4695	4695	4695	4205	4205
C (mm)	SE/XL	1145	1145	1145	1145	2190	2190
kg	SE/XL	1480	1830	1850	2150	2700	2740

# LHA

## HIGH EFFICIENCY AIR TO WATER HEAT PUMPS

Heating capacity from 22 kW to 460 kW

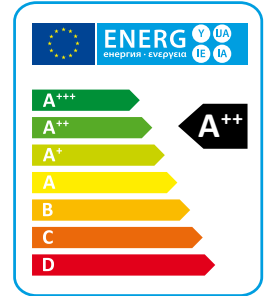

R410A



The LHA series of high efficiency heat pumps has been specifically designed for use with radiant floor heating systems or those applications where it is necessary to have maximum efficiency when heating.

They have been optimized on heating mode, are able to produce water up to 60°C and can operate down to -20°C ambient temperature.

All versions are supplied with reverse cycle valve used for winter defrost; the HH version is suitable for use in those countries that have support schemes for use of heat pump technology for heating. The RV versions are also able to produce cold water. The HH heating only versions is factory set and locked to operate only in heating mode whilst.

The noise is extremely low thanks to the use of a special floating vibration damping system which allows a noise reduction of about 6-8 dB(A) (Optional).

### VERSIONS

- HH** Heating only.
- RV** Reversible heating/cooling.
- SA** Standard efficiency, AC fans.
- SE** Standard efficiency, EC fans.
- HA** High efficiency, AC fans.
- HE** High efficiency, EC fans.
- LS** Low noise.
- XL** Super low noise.
- P2U** 2 pipe systems without domestic hot water production.
- P2S** 2 pipe systems with domestic hot water production by external 3 way valve.

Heating only version (HH)

SA/LS/HH - P2S/P2U	242	292	402	432	492	592	702	802	902	1002	1202	1402
Heating capacity (EN14511) <sup>(1)</sup> kW	22,0	28,7	34,5	47,2	50,9	56,8	64,9	73,2	80,2	97,0	105,7	122,3
Total input power (EN14511) <sup>(1)</sup> kW	5,8	7,3	9,1	12,2	12,6	14,4	16,0	17,9	20,8	24,3	27,3	30,7
COP (EN14511) <sup>(1)</sup> W/W	3,83	3,93	3,80	3,86	4,04	3,94	4,06	4,10	3,86	4,00	3,87	3,98
Energy Class <sup>(2)</sup>	A+	A+	A+	A+	A+	A+	A+	A+	A+	A+	A+	A+
SCOP <sup>(2)</sup> kWh/kWh	3,27	3,58	3,41	3,34	3,48	3,54	3,43	3,47	3,42	3,50	3,39	3,50
η <sub>s,h</sub> <sup>(2)</sup> %	127,9	140,1	133,3	130,4	136,3	138,6	134,3	135,9	133,7	137,1	132,7	136,9
Sound power <sup>(3)</sup> dB (A)	75	75	75	75	77	77	77	78	79	82	83	85
Sound pressure <sup>(4)</sup> dB (A)	43	43	43	43	45	45	45	46	47	50	51	53
SE/LS/HH - P2S/P2U	242	292	402	432	492	592	702	802	902	1002	1202	1402
Heating capacity (EN14511) <sup>(1)</sup> kW	21,9	28,6	34,2	47,1	51,1	57,1	64,9	73,1	81,0	97,0	105,6	122,7
Total input power (EN14511) <sup>(1)</sup> kW	5,6	7,2	8,8	11,9	12,4	14,4	15,8	17,6	20,9	24,0	27,3	30,5
COP (EN14511) <sup>(1)</sup> W/W	3,92	3,95	3,87	3,95	4,13	3,97	4,10	4,15	3,88	4,04	3,87	4,02
Energy Class <sup>(2)</sup>	A+	A+	A+	A+	A+	A+	A+	A+	A+	A+	A+	A+
SCOP <sup>(2)</sup> kWh/kWh	3,40	3,66	3,53	3,46	3,59	3,62	3,68	3,71	3,63	3,71	3,64	3,73
η <sub>s,h</sub> <sup>(2)</sup> %	132,8	143,2	138,3	135,5	140,4	141,7	144,1	145,4	142,1	145,3	142,5	146,1
Sound power <sup>(3)</sup> dB (A)	74	74	75	75	77	77	77	78	79	82	83	85
Sound pressure <sup>(4)</sup> dB (A)	42	42	43	43	45	45	45	46	47	50	51	53
Power supply	V/Ph/Hz	400/3+N/50	400/3+N/50	400/3+N/50	400/3/50	400/3/50	400/3/50	400/3/50	400/3/50	400/3/50	400/3/50	400/3/50
Compressors / Circuits	n° / n°	2 / 1	2 / 1	2 / 1	2 / 1	2 / 1	2 / 1	2 / 1	2 / 1	2 / 1	2 / 1	2 / 1
Fans	n°	1	1	2	2	2	2	2	2	3	3	3
Refrigerant		R410A	R410A	R410A	R410A	R410A	R410A	R410A	R410A	R410A	R410A	R410A
Refrigerant charge	kg	10,0	10,0	10,0	10,0	14,5	14,5	14,5	14,5	21,0	21,0	27,0
Global warming potential (GWP)		2088	2088	2088	2088	2088	2088	2088	2088	2088	2088	2088
Equivalent CO <sub>2</sub> charge	t	20,88	20,88	20,88	20,88	30,27	30,27	30,27	30,27	43,84	43,84	56,37
Water tank volume	l	100	100	100	100	100	100	300	300	300	500	500

SA/LS/HH - P2S/P2U	1602	1802	2002	2302	2502	2504	3004	3204	3504	4004	4504	5004 *
Heating capacity (EN14511) <sup>(1)</sup> kW	136,0	157,3	169,0	196,6	215,0	211,8	226,1	258,8	330,6	357,4	393,3	431,7
Total input power (EN14511) <sup>(1)</sup> kW	34,6	40,3	43,4	51,5	60,4	58,2	64,8	71,9	85,2	93,8	103,0	116,4
COP (EN14511) <sup>(1)</sup> W/W	3,93	3,90	3,89	3,82	3,56	3,64	3,49	3,60	3,88	3,81	3,82	3,71
Energy Class <sup>(2)</sup>	A+	A+	A+	A+	A+	A+	A+	A+	A+	A+	A+	A+
SCOP <sup>(2)</sup> kWh/kWh	3,50	3,48	3,46	3,45	3,24	3,25	3,23	3,26	3,25	3,27	3,24	3,34
η <sub>s,h</sub> <sup>(2)</sup> %	137,0	136,1	135,5	134,8	126,5	127,1	126,1	127,2	127,0	127,8	126,4	130,4
Sound power <sup>(3)</sup> dB (A)	86	86	86	89	90	87	89	90	90	90	92	93
Sound pressure <sup>(4)</sup> dB (A)	54	54	54	57	58	55	57	58	58	58	60	61
SE/LS/HH - P2S/P2U	1602	1802	2002	2302	2502	2504	3004	3204	3504	4004	4504	5004 *
Heating capacity (EN14511) <sup>(1)</sup> kW	137,0	157,8	170,2	197,7	217,6	213,2	227,7	261,7	330,6	357,5	396,6	435,4
Total input power (EN14511) <sup>(1)</sup> kW	34,6	38,8	43,3	51,5	60,3	57,9	65,1	71,9	82,9	92,1	102,7	116,7
COP (EN14511) <sup>(1)</sup> W/W	3,96	4,07	3,93	3,84	3,61	3,68	3,50	3,64	3,99	3,88	3,86	3,73
Energy Class <sup>(2)</sup>	A+	A+	A+	A+	A+	A+	A+	A+	A+	A+	A+	A+
SCOP <sup>(2)</sup> kWh/kWh	3,68	3,77	3,72	3,74	3,63	3,54	3,49	3,46	3,52	3,57	3,63	3,58
η <sub>s,h</sub> <sup>(2)</sup> %	144,0	147,8	145,8	146,4	142,1	138,6	136,5	135,2	137,9	139,6	142,3	140,0
Sound power <sup>(3)</sup> dB (A)	86	86	86	89	90	87	89	90	90	90	92	93
Sound pressure <sup>(4)</sup> dB (A)	54	54	54	57	58	55	57	58	58	58	60	61
Power supply	V/Ph/Hz	400/3/50	400/3/50	400/3/50	400/3/50	400/3/50	400/3/50	400/3/50	400/3/50	400/3/50	400/3/50	400/3/50
Compressors / Circuits	n° / n°	2 / 1	2 / 1	2 / 1	2 / 1	4 / 2	4 / 2	4 / 2	4 / 2	4 / 2	4 / 2	4 / 2
Fans	n°	4	4	4	3	4	4	4	6	6	6	8
Refrigerant		R410A	R410A	R410A	R410A	R410A	R410A	R410A	R410A	R410A	R410A	R410A
Refrigerant charge	kg	27,0	36,0	36,0	45,0	45,0	45,0	54,0	54,0	72,0	80,0	100,0
Global warming potential (GWP)		2088	2088	2088	2088	2088	2088	2088	2088	2088	2088	2088
Equivalent CO <sub>2</sub> charge	t	56,37	75,16	75,16	93,96	93,96	93,96	112,75	112,75	150,33	167,04	208,80
Water tank volume	l	500	500	500	500	500	500	500	1000	1000	1000	1000

\* Units only available for the non-EU market

Performances are referred to the following conditions:

(1) Heating: Ambient temperature 7°C DB, 6°C WB, water temperature 30/35°C.

(2) Average conditions, low temperature, variable - Reg EU 811/2013

(3) Sound power level in accordance with ISO 3744.

(4) Sound pressure level at 10 mt from the unit in free field conditions in accordance with ISO 3744.

Heating only version (HH)

HA/LS/HH - P2S/P2U	242	292	412	432	492	602	702	802	902	1002	1202	1402
Heating capacity (EN14511) <sup>(1)</sup> kW	22,2	29,6	37,3	46,9	50,7	61,2	67,3	72,6	93,1	104,7	114,4	137,2
Total input power (EN14511) <sup>(1)</sup> kW	5,3	7,1	9,0	11,4	12,0	13,6	15,4	17,0	22,1	25,3	28,4	32,4
COP (EN14511) <sup>(1)</sup> W/W	4,11	4,12	4,13	4,11	4,22	4,49	4,38	4,27	4,21	4,14	4,03	4,24
Energy Class <sup>(2)</sup>	A+	A+	A+	A+	A+	A++	A++	A++	A+	A+	A+	A+
SCOP <sup>(2)</sup> kWh/kWh	3,40	3,69	3,53	3,57	3,67	3,97	3,91	3,87	3,70	3,67	3,69	3,70
η <sub>s,h</sub> <sup>(2)</sup> %	132,9	144,7	138,0	139,6	143,8	155,7	153,4	151,6	145,1	143,7	144,4	144,8
Sound power <sup>(3)</sup> dB (A)	75	75	75	75	76	76	77	78	82	83	85	86
Sound pressure <sup>(4)</sup> dB (A)	43	43	43	43	44	44	45	46	50	51	53	54
HE/LS/HH - P2S/P2U	252	302	412	432	492	602	702	802	902	1002	1202	1402
Heating capacity (EN14511) <sup>(1)</sup> kW	22,2	29,6	37,3	47,1	50,8	61,2	67,3	74,9	93,2	104,9	114,9	137,1
Total input power (EN14511) <sup>(1)</sup> kW	5,3	7,1	8,8	11,5	11,8	13,3	15,1	17,2	21,2	24,5	27,8	30,9
COP (EN14511) <sup>(1)</sup> W/W	4,11	4,16	4,23	4,11	4,32	4,61	4,46	4,36	4,40	4,29	4,13	4,44
Energy Class <sup>(2)</sup>	A++	A++	A++	A++	A++	A++	A++	A++	A++	A++	A++	A++
SCOP <sup>(2)</sup> kWh/kWh	3,83	3,86	3,85	3,85	3,92	4,13	4,04	3,97	3,87	3,85	3,83	3,85
η <sub>s,h</sub> <sup>(2)</sup> %	150,1	151,4	150,9	151,1	153,6	162,0	158,4	155,8	151,7	150,8	150,2	151,0
Sound power <sup>(3)</sup> dB (A)	73	74	74	75	76	76	77	78	82	83	85	86
Sound pressure <sup>(4)</sup> dB (A)	41	42	42	43	44	44	45	46	50	51	53	54
Power supply	V/Ph/Hz 400/3+N/50 400/3+N/50 400/3/50 400/3/50 400/3/50 400/3/50 400/3/50 400/3/50 400/3/50 400/3/50 400/3/50 400/3/50 400/3/50											
Compressors / Circuits	n° / n°	2 / 1	2 / 1	2 / 1	2 / 1	2 / 1	2 / 1	2 / 1	2 / 1	2 / 1	2 / 1	2 / 1
Fans	n°	1	1	2	2	2	2	2	2	2	2	3
Refrigerant		R410A	R410A	R410A	R410A	R410A	R410A	R410A	R410A	R410A	R410A	R410A
Refrigerant charge	kg	10,0	10,0	10,0	10,0	14,5	19,0	19,0	19,0	27,0	27,0	36,0
Global warming potential (GWP)		2088	2088	2088	2088	2088	2088	2088	2088	2088	2088	2088
Equivalent CO <sub>2</sub> charge	t	20,88	20,88	20,88	20,88	30,27	39,67	39,67	39,67	56,37	56,37	75,16
Water tank volume	l	100	100	100	100	100	300	300	300	300	300	500

HA/LS/HH - P2S/P2U	1602	1802	2002	2302	2502	2504	3004	3204	3504	4004	4504	5004 *
Heating capacity (EN14511) <sup>(1)</sup> kW	150,8	167,2	182,0	209,7	239,2	228,6	270,2	295,6	335,0	363,1	398,6	458,7
Total input power (EN14511) <sup>(1)</sup> kW	35,8	41,3	45,4	50,3	55,8	56,7	67,0	74,1	83,5	90,3	103,5	116,4
COP (EN14511) <sup>(1)</sup> W/W	4,21	4,05	4,01	4,17	4,29	4,03	4,03	3,99	4,01	4,02	3,85	3,94
Energy Class <sup>(2)</sup>	A+	A+	A+	A+	A++	A+	A+	A+	A+	A+	A+	A+
SCOP <sup>(2)</sup> kWh/kWh	3,74	3,69	3,62	3,76	3,83	3,65	3,63	3,65	3,66	3,73	3,61	3,63
η <sub>s,h</sub> <sup>(2)</sup> %	146,4	144,7	141,9	147,3	150,3	143,1	142,0	142,9	143,3	146,1	141,4	142,0
Sound power <sup>(3)</sup> dB (A)	87	87	87	89	91	88	89	90	90	90	92	92
Sound pressure <sup>(4)</sup> dB (A)	55	55	55	57	59	56	57	58	58	58	60	60
HE/LS/HH - P2S/P2U	1602	1802	2002	2302	2502	2504	3004	3204	3504	4004	4504	5004 *
Heating capacity (EN14511) <sup>(1)</sup> kW	151,0	167,9	182,8	210,6	241,3	229,4	271,4	296,7	339,0	364,9	399,1	463,7
Total input power (EN14511) <sup>(1)</sup> kW	34,4	40,2	45,5	49,4	54,8	55,8	63,9	71,5	83,7	88,8	102,1	115,1
COP (EN14511) <sup>(1)</sup> W/W	4,39	4,18	4,02	4,26	4,40	4,11	4,25	4,15	4,05	4,11	3,91	4,03
Energy Class <sup>(2)</sup>	A++	A++	A++	A++	A++	A++	A++	A++	A++	A++	A++	A++
SCOP <sup>(2)</sup> kWh/kWh	3,86	3,85	3,84	3,92	3,97	3,83	3,85	3,83	3,91	3,89	3,87	3,86
η <sub>s,h</sub> <sup>(2)</sup> %	151,3	150,9	150,4	153,6	155,6	150,2	151,1	150,3	153,5	152,4	151,9	151,5
Sound power <sup>(3)</sup> dB (A)	87	87	87	89	91	88	89	90	90	90	92	92
Sound pressure <sup>(4)</sup> dB (A)	55	55	55	57	59	56	57	58	58	58	60	60
Power supply	V/Ph/Hz 400/3/50 400/3/50 400/3/50 400/3/50 400/3/50 400/3/50 400/3/50 400/3/50 400/3/50 400/3/50 400/3/50 400/3/50 400/3/50											
Compressors / Circuits	n° / n°	2 / 1	2 / 1	2 / 1	2 / 1	2 / 1	4 / 2	4 / 2	4 / 2	4 / 2	4 / 2	4 / 2
Fans	n°	3	3	3	3	3	4	6	6	6	8	8
Refrigerant		R410A	R410A	R410A	R410A	R410A	R410A	R410A	R410A	R410A	R410A	R410A
Refrigerant charge	kg	36,0	36,0	45,0	45,0	60,0	60,0	72,0	72,0	72,0	90,0	100,0
Global warming potential (GWP)		2088	2088	2088	2088	2088	2088	2088	2088	2088	2088	2088
Equivalent CO <sub>2</sub> charge	t	75,16	75,16	93,96	93,96	125,28	125,28	150,33	150,33	150,33	187,92	208,80
Water tank volume	l	500	500	500	500	1000	1000	1000	1000	1000	1000	1000

\* Units only available for the non-EU market

Performances are referred to the following conditions:

(1) Heating: Ambient temperature 7°C DB, 6°C WB, water temperature 30/35°C.

(2) Average conditions, low temperature, variable - Reg EU 811/2013

(3) Sound power level in accordance with ISO 3744.

(4) Sound pressure level at 10 mt from the unit in free field conditions in accordance with ISO 3744.





Reversible heating/cooling version (RV)

HA/LS/RV - P2S/P2U	242	292	412	432	492	602	702	802	902	1002	1202	1402
Heating capacity (EN14511) <sup>(1)</sup> kW	22,2	29,6	37,3	46,9	50,7	61,2	67,3	72,6	93,1	104,7	114,4	137,2
Total input power (EN14511) <sup>(1)</sup> kW	5,3	7,1	9,0	11,4	12,0	13,6	15,4	17,0	22,1	25,3	28,4	32,4
COP (EN14511) <sup>(1)</sup> W/W	4,11	4,12	4,13	4,11	4,22	4,49	4,38	4,27	4,21	4,14	4,03	4,24
Energy Class <sup>(2)</sup>	A+	A+	A+	A+	A+	A++	A++	A++	A+	A+	A+	A+
SCOP <sup>(2)</sup>	3,40	3,69	3,53	3,57	3,67	3,97	3,91	3,87	3,70	3,67	3,69	3,70
η <sub>s,h</sub> <sup>(2)</sup> %	132,9	144,7	138,0	139,6	143,8	155,7	153,4	151,6	145,1	143,7	144,4	144,8
Cooling capacity (EN14511) <sup>(3)</sup> kW	18,1	24,5	30,8	39,9	44,2	52,3	57,4	62,6	79,8	89,6	97,8	117,0
Total input power (EN14511) <sup>(3)</sup> kW	7,0	9,6	10,9	15,0	16,3	18,4	21,5	24,5	27,2	31,7	36,5	43,8
EER (EN14511) <sup>(3)</sup> W/W	2,57	2,56	2,84	2,65	2,72	2,84	2,67	2,55	2,93	2,83	2,68	2,67
Sound power <sup>(4)</sup> dB (A)	75	75	75	75	76	76	77	78	82	83	85	86
Sound pressure <sup>(5)</sup> dB (A)	43	43	43	43	44	44	45	46	50	51	53	54

HE/LS/RV - P2S/P2U	242	292	412	432	492	602	702	802	902	1002	1202	1402
Heating capacity (EN14511) <sup>(1)</sup> kW	22,2	29,6	37,3	47,1	50,8	61,2	67,3	74,9	93,2	104,9	114,9	137,1
Total input power (EN14511) <sup>(1)</sup> kW	5,3	7,1	8,8	11,5	11,8	13,3	15,1	17,2	21,2	24,5	27,8	30,9
COP (EN14511) <sup>(1)</sup> W/W	4,11	4,16	4,23	4,11	4,32	4,61	4,46	4,36	4,40	4,29	4,13	4,44
Energy Class <sup>(2)</sup>	A++	A++	A++	A++	A++	A++	A++	A++	A++	A++	A++	A++
SCOP <sup>(2)</sup>	3,83	3,86	3,85	3,85	3,92	4,13	4,04	3,97	3,87	3,85	3,83	3,85
η <sub>s,h</sub> <sup>(2)</sup> %	150,1	151,4	150,9	151,1	153,6	162,0	158,4	155,8	151,7	150,8	150,2	151,0
Cooling capacity (EN14511) <sup>(3)</sup> kW	18,1	25,4	30,5	40,6	44,2	52,4	57,5	65,4	80,5	90,2	100,5	117,4
Total input power (EN14511) <sup>(3)</sup> kW	6,9	8,4	11,0	14,5	16,1	18,3	21,3	22,8	26,6	31,2	35,1	38,6
EER (EN14511) <sup>(3)</sup> W/W	2,62	3,02	2,78	2,81	2,74	2,87	2,70	2,87	3,03	2,89	2,86	3,04
Sound power <sup>(4)</sup> dB (A)	73	74	74	75	76	76	77	78	82	83	85	86
Sound pressure <sup>(5)</sup> dB (A)	41	42	42	43	44	44	45	46	50	51	53	54
Power supply	V/Ph/Hz 400/3+N/50 400/3+N/50 400/3/50 400/3/50 400/3/50 400/3/50 400/3/50 400/3/50 400/3/50 400/3/50 400/3/50 400/3/50											
Compressors / Circuits	n° / n° 2 / 1 2 / 1 2 / 1 2 / 1 2 / 1 2 / 1 2 / 1 2 / 1 2 / 1 2 / 1 2 / 1 2 / 1 2 / 1											
Fans	n° 1 1 2 2 2 2 2 2 2 2 2 2 3											
Refrigerant	R410A R410A R410A R410A R410A R410A R410A R410A R410A R410A R410A R410A R410A											
Refrigerant charge	kg 10,0 10,0 10,0 10,0 14,5 19,0 19,0 19,0 27,0 27,0 27,0 36,0											
Global warming potential (GWP)	2088 2088 2088 2088 2088 2088 2088 2088 2088 2088 2088 2088											
Equivalent CO <sub>2</sub> charge	t 20,88 20,88 20,88 20,88 30,27 39,67 39,67 39,67 56,37 56,37 56,37 75,16											
Water tank volume	l 100 100 100 100 100 300 300 300 300 300 300 500											

HA/LS/RV - P2S/P2U	1602	1802	2002	2302	2502	2504	3004	3204	3504	4004	4504	5004 *
Heating capacity (EN14511) <sup>(1)</sup> kW	150,8	167,2	182,0	209,7	239,2	228,6	270,2	295,6	335,0	363,1	398,6	458,7
Total input power (EN14511) <sup>(1)</sup> kW	35,8	41,3	45,4	50,3	55,8	56,7	67,0	74,1	83,5	90,3	103,5	116,4
COP (EN14511) <sup>(1)</sup> W/W	4,21	4,05	4,01	4,17	4,29	4,03	4,03	3,99	4,01	4,02	3,85	3,94
Energy Class <sup>(2)</sup>	A+	A+	A+	A+	A++	A+	A+	A+	A+	A+	A+	A+
SCOP <sup>(2)</sup>	3,74	3,69	3,62	3,76	3,83	3,65	3,63	3,65	3,66	3,73	3,61	3,63
η <sub>s,h</sub> <sup>(2)</sup> %	146,4	144,7	141,9	147,3	150,3	143,1	142,0	142,9	143,3	146,1	141,4	142,0
Cooling capacity (EN14511) <sup>(3)</sup> kW	129,5	144,5	159,3	180,2	199,7	197,4	230,1	257,2	288,2	325,6	366,0	405,0
Total input power (EN14511) <sup>(3)</sup> kW	44,3	51,8	58,8	66,3	74,5	73,1	81,9	91,5	105,6	116,7	136,1	155,2
EER (EN14511) <sup>(3)</sup> W/W	2,92	2,79	2,71	2,72	2,68	2,70	2,81	2,81	2,73	2,79	2,69	2,61
Sound power <sup>(4)</sup> dB (A)	87	87	87	89	91	88	89	90	90	90	92	92
Sound pressure <sup>(5)</sup> dB (A)	55	55	55	57	59	56	57	58	58	58	60	60

HE/LS/RV - P2S/P2U	1602	1802	2002	2302	2502	2504	3004	3204	3504	4004	4504	5004 *
Heating capacity (EN14511) <sup>(1)</sup> kW	151,0	167,9	182,8	210,6	241,3	229,4	271,4	296,7	339,0	364,9	399,1	463,7
Total input power (EN14511) <sup>(1)</sup> kW	34,4	40,2	45,5	49,4	54,8	55,8	63,9	71,5	83,7	88,8	102,1	115,1
COP (EN14511) <sup>(1)</sup> W/W	4,39	4,18	4,02	4,26	4,40	4,11	4,25	4,15	4,05	4,11	3,91	4,03
Energy Class <sup>(2)</sup>	A++	A++	A++	A++	A++	A++	A++	A++	A++	A++	A++	A++
SCOP <sup>(2)</sup>	3,86	3,85	3,84	3,92	3,97	3,83	3,85	3,83	3,91	3,89	3,87	3,86
η <sub>s,h</sub> <sup>(2)</sup> %	151,3	150,9	150,4	153,6	155,6	150,2	151,1	150,3	153,5	152,4	151,9	151,5
Cooling capacity (EN14511) <sup>(3)</sup> kW	129,5	146,8	159,2	180,4	202,1	198,5	231,0	259,7	289,4	322,6	368,5	416,0
Total input power (EN14511) <sup>(3)</sup> kW	44,0	50,8	58,7	66,1	73,2	72,7	80,5	89,2	105,2	118,2	135,0	154,6
EER (EN14511) <sup>(3)</sup> W/W	2,94	2,89	2,71	2,73	2,76	2,73	2,87	2,91	2,75	2,73	2,73	2,69
Sound power <sup>(4)</sup> dB (A)	87	87	87	89	91	88	89	90	90	90	92	92
Sound pressure <sup>(5)</sup> dB (A)	55	55	55	57	59	56	57	58	58	58	60	60
Power supply	V/Ph/Hz 400/3/50 400/3/50 400/3/50 400/3/50 400/3/50 400/3/50 400/3/50 400/3/50 400/3/50 400/3/50 400/3/50 400/3/50											
Compressors / Circuits	n° / n° 2 / 1 2 / 1 2 / 1 2 / 1 2 / 1 4 / 2 4 / 2 4 / 2 4 / 2 4 / 2 4 / 2 4 / 2 4 / 2											
Fans	n° 3 3 3 3 3 4 6 6 6 6 8 8											
Refrigerant	R410A R410A R410A R410A R410A R410A R410A R410A R410A R410A R410A R410A R410A											
Refrigerant charge	kg 36,0 36,0 45,0 45,0 60,0 60,0 72,0 72,0 90,0 90,0 90,0 100,0											
Global warming potential (GWP)	2088 2088 2088 2088 2088 2088 2088 2088 2088 2088 2088 2088											
Equivalent CO <sub>2</sub> charge	t 75,16 75,16 93,96 93,96 125,28 125,28 150,33 150,33 150,33 187,92 187,92 208,80											
Water tank volume	l 500 500 500 500 1000 1000 1000 1000 1000 1000 1000 1000											

\* Units only available for the non-EU market

Performances are referred to the following conditions:  
 (1) Heating: Ambient temperature 7°C DB, 6°C WB, water temperature 30/35°C.  
 (2) Average conditions, low temperature, variable - Reg EU 811/2013

(3) Cooling: ambient air temperature 35°C, evaporator water temperature in/out 12/7 °C.  
 (4) Sound power level in accordance with ISO 3744..  
 (5) Sound pressure level at 10 mt from the unit in free field conditions in accordance with ISO 3744.



## COMPONENTS

### FRAME

All units are made from hot-galvanised sheet steel, painted with polyurethane powder enamel and stoved at 180°C to provide maximum protection against corrosion. The frame is self-supporting with removable panels. All screws and rivets used are made from stainless steel. The standard colour of the units is RAL9018.

### REFRIGERANT CIRCUIT

The refrigerant utilised is R410A. The refrigerant circuit is assembled using internationally recognised brand name components with all brazing and welding being performed in accordance with ISO 97/23. The refrigerant circuit includes: sight glass, filter drier, two thermal expansion valves (one for cooling mode, one for heating mode) with external equalizer, 4 way reversing valve, check valves, liquid receiver, Schrader valves for maintenance and control, pressure safety device (for compliance with PED regulations).

### COMPRESSORS

The compressors used are a high performance scroll type that incorporates a special scroll design which enhances the efficiency of the refrigerant cycle when the source temperature is low. In all units the compressors are connected in tandem.

The compressors are all supplied with a crankcase heater and thermal overload protection by a klixon embedded in the motor winding. They are mounted in a separate enclosure in order to be separated from the air stream thus enabling them to be maintained even if the unit is operating. Access to this enclosure is by the front panel of the unit. The crankcase heater is always powered when the compressor is in stand-by.

### SOURCE HEAT EXCHANGER

The source heat exchanger is made from copper pipes and aluminium fins. Dimensioning of the copper pipes and the aluminium fins is optimized in order to obtain excellent performance. The tubes are mechanically expanded into the fins in order to maximise heat transfer. Furthermore, the design guarantees a low air side pressure drop thus enabling the use of low rotation speed (and hence low noise) fans. All heat exchangers are supplied standard with fins hydrophilic coating.

### USER HEAT EXCHANGERS

The user heat exchanger is a braze welded, plate type heat exchanger, manufactured from AISI 316 stainless steel. The use of this type of exchanger results in a massive reduction of the refrigerant charge of the unit compared to a traditional shell-in-tube type. A further advantage is a reduction in the overall dimensions of the unit.

The exchangers are factory insulated with flexible close cell material and can be fitted with an antifreeze heater (accessory). Each exchanger is fitted with a temperature sensor on the discharge water side for antifreeze protection.

### FANS

The fans are direct drive axial type with aluminium aerofoil blades, are statically and dynamically balanced and are supplied complete with a safety fan guard complying with the requirements of EN 60335. They are fixed to the unit frame via rubber anti-vibration mountings. The electric motors, in LS versions are 6 poles type rotating at approximately 900 rpm. In the XL versions the fans are 8 poles type (approx 600 rpm). The motors are fitted with integrated thermal overload protection and have a moisture protection rating of IP 54.

### MICROPROCESSORS

All units are supplied as standard complete with control panel. The microprocessor controls the following functions: control of the water temperature, antifreeze protection, compressor timing, compressor automatic starting sequence (For multiple compressors), alarm reset. The control panel is supplied with

display showing all operational icons. The microprocessor is set for automatic defrost (when operating in severe ambient conditions) and for summer/ winter change over (only for RV versions). The control also manages the anti-legionella program, the integration with other heating sources (electric heaters, boilers, solar panels etc), the operation of a three port modulating valve (for diverting to DHW or heating) and both the heating circuit pump and the domestic hot water circuit pump. If required (available as an option), the microprocessor can be configured in order for it to connect to a site BMS system thus enabling remote control and management.

### ELECTRIC ENCLOSURE

The enclosure is manufactured in order to comply with the requirements of the electromagnetic compatibility standards CEE EN60204. Access to the enclosure is achieved by removing the front panel of the unit. The following components are supplied as standard on all units: main switch, a sequence relay that disables the power supply in the event that the phase sequence is incorrect (scroll compressors can be damaged if they rotate in the wrong direction), thermal overloads (protection of pumps and fans), compressor fuses, control circuit automatic breakers, compressor contactors, fan contactors and pump contactors. The terminal board has volt free contacts for remote ON-OFF, Summer/ winter change over (heat pumps only) and general alarm.

### CONTROL AND PROTECTION DEVICES

All units are supplied with the following controls and protections: user water return temperature sensor, antifreeze protection temperature sensor installed on users water output, domestic hot water supply and return temperature sensors (only versions P2S), high pressure manual reset, low pressure automatic reset, compressor thermal protection, air fan, thermal protection, pressure transducer (used to optimize the defrost cycle and to adjust the fan speed depending on ambient conditions), flow switch. All units in HA and HE versions are also fitted with a temperature probe sensor with "Energy Saving" function, supplied in a separate plastic box, which can be used to stop the pump use during periods of stand-by, when the water temperature reaches the set point. Doing this the power consumption of the unit is strongly reduced. The probe sensor must be positioned in the hydraulic compensator present at the screening technique. The domestic hot water circuit (only versions P2S) is already equipped with this probe, but it must be installed in the user circuit.

## VERSIONS

### HA/XL HE/XL Super low noise version

All HA and HE units in XL super low noise version are supplied, as standard, with the latest 'Floating Frame' technology that completely isolates the compressors from the main casing, thereby eliminating vibration and noise from this source. The 'Floating Frame' is a special vibration and acoustic damping system that consists of a base plate and acoustic enclosure that houses the compressors. The base plate is separated from the supporting frame of the unit by soft steel springs that have a high damping power. Within the enclosure, the compressors are mounted on rubber shock absorbers on the floating base plate. The enclosure is manufactured from galvanized steel sandwich panels that have a micro-perforated inner skin and a core of 30 mm thick, high density (25 kg/m<sup>3</sup>). The entire arrangement provides a double damping system and acoustic attenuation. The compressor refrigerant pipes are connected to the refrigerant circuit through "anaconda" flexible connections. Flexible connections are also used on the water pipework within the unit. The combination of these systems results in an overall noise reduction in the region of 6-8 dB(A).

### VERSION HH

HH heating only versions are available in the P2U and P2S configuration only.

### Version RV

This version uses 2 hydraulic connections and is able to produce hot water in winter and cold water in summer. The unit is combined with a 2-pipe system.

### SA Version

Standard efficiency version, according to current standard. Unit equipped with AC fans.

### SE Version

Standard efficiency version, according to current standard. Unit equipped with EC fans.

### HA Version

High efficiency version, according to current standard. Unit equipped with AC fans.

### HE Version

High efficiency version, according to current standard. Unit equipped with EC fans.

### Version LS

This version includes the complete acoustic insulation of the unit with compressor jackets and insulating material made with high density media and the interposition of heavy bitumen layer.

### P2U Version

This is a two pipe version that can produce hot water for heating (HH heating only) and hot or cold water in the RV version. The RV is used with two pipe water based change-over systems. It is not able to produce domestic hot water.

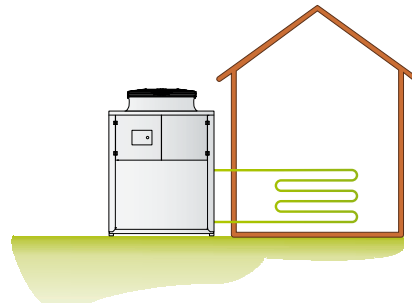

### P2S Version

This is a two pipe version that can, in addition to producing hot water for heating (HH version) and hot and cold water in the RV version can also generate domestic hot water. The controller has dual heating set points (heating and DHW) and can also control a three port diverting valve that directs the DHW to the cylinder. DHW production has priority irrespective of the mode of operation of the unit. The unit is normally used with two pipe water based change-over systems.

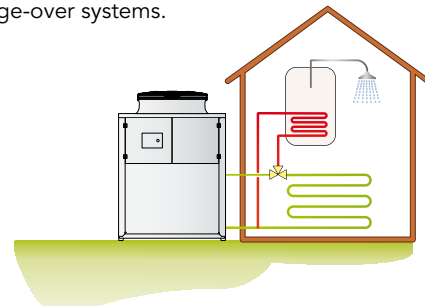

## OPERATION LIMITS

(SA/SE versions)

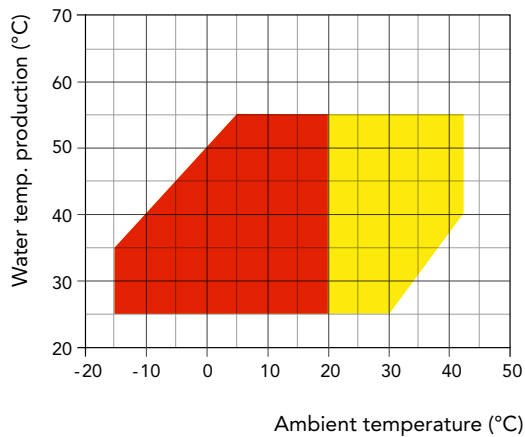

(HA/HE versions)

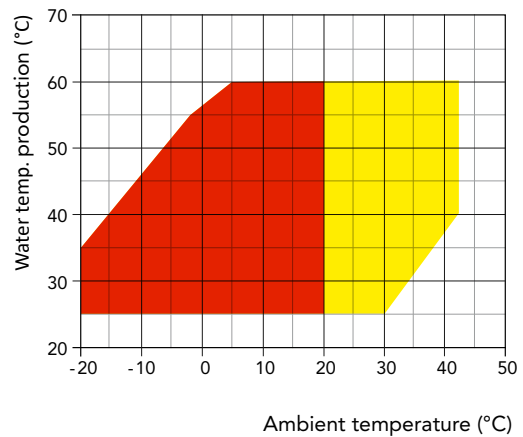

(RV versions Only)

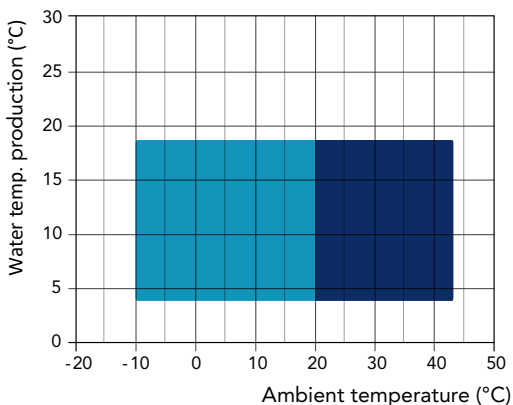

- Heating mode
- Heating mode with head pressure control (DCCF)
- Cooling with head pressure control (DCCF)
- Cooling mode

LHA SA-SE/HH-RV	LHA HA-HE /HH-RV	P2S/P2U	242 252	292 302	402	412	432	492	592	602	702	802	902	1002	1202
Flow switch			●	●	●	●	●	●	●	●	●	●	●	●	●
"Floating frame" Technology - LS Version			-	-	-	-	-	-	-	-	-	-	-	-	-
"Floating frame" Technology - XL Version			●	●	●	●	●	●	●	●	●	●	●	●	●
E.C. fans - SA versions	VECE		-	-	-	-	-	-	-	-	-	-	-	-	-
E.C. fans - SE versions	VECE		●	●	●	●	●	●	●	●	●	●	●	●	●
E.C. fans - HA versions	VECE		-	-	-	-	-	-	-	-	-	-	-	-	-
E.C. fans - HE versions	VECE		●	●	●	●	●	●	●	●	●	●	●	●	●
Condensate discharge drip tray with antifreeze heater	BRCA		○	○	○	○	○	○	○	○	○	○	○	○	○
Fans regulation by phase cut	DCCF		X	X	X	X	X	X	X	X	X	X	X	X	X
Antifreeze kit for 2 pipe units	RAEV2		○	○	○	○	○	○	○	○	○	○	○	○	○
Electronic soft starter	DSSE		○	○	○	○	○	○	○	○	○	○	○	○	○
Serial interface card RS485	INSE		●	●	●	●	●	●	●	●	●	●	●	●	●
Rubber anti-vibration mountings	KAVG		○	○	○	○	○	○	○	○	○	○	○	○	○
Remote control panel	PCRL		○	○	○	○	○	○	○	○	○	○	○	○	○
Electronic expansion valve	VTEE		○	○	○	○	○	○	○	○	○	○	○	○	○
Cascade control system via RS485	SGRS		○	○	○	○	○	○	○	○	○	○	○	○	○
Hydraulic kit with one pump with tank	A1ZZU		○	○	○	○	○	○	○	○	○	○	○	○	○
Hydraulic kit with two pumps with tank	A2ZZU		○	○	○	○	○	○	○	○	○	○	○	○	○
Hydraulic kit with one pump without tank	A1NTU		○	○	○	○	○	○	○	○	○	○	○	○	○
Hydraulic kit with two pumps without tank	A2NTU		○	○	○	○	○	○	○	○	○	○	○	○	○

X Necessary for P2S version    ● Standard ○ Optional - Not available  
Optional for P2U version

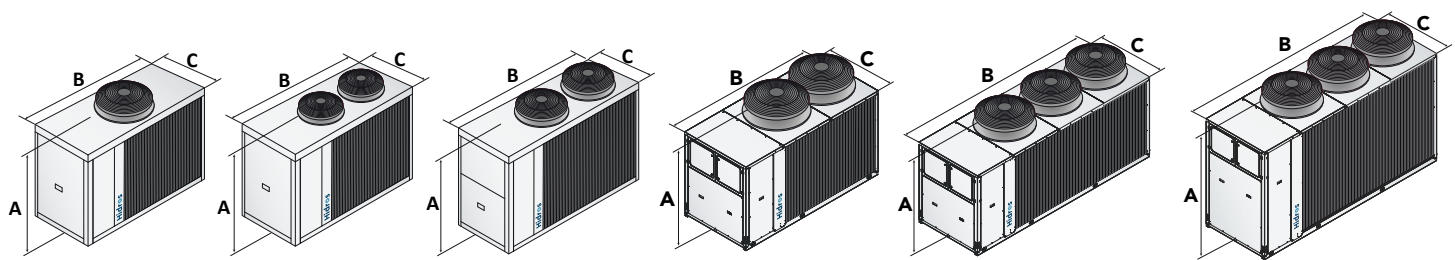

**SA/SE 242 - 292**    **SA/SE 402**    **SA/SE 432 - 492 - 592**    **SA/SE 702 - 802 - 902**    **SA/SE 1002 - 1202 - 1402**    **SA/SE 1802 - 2002**  
**HA/HE LS 242 - 292**    **HA/HE XL 252 - 302**    **HA/HE-LS/XL 412 - 432**    **HA/HE-LS/XL 602 - 702**    **HA/HE-LS/XL 1402 - 1602**    **HA/HE-LS/XL 2302 - 2502**  
 492    802 - 902 - 1002 - 1202    1802- 2002

		242/252	292/302	402	412	432	492	592	602	702	802	902	1002	1202
A (mm)	SA-SE/LS	1500	1500	1500	--	1690	1690	1690	--	1880	1880	1880	1880	1880
B (mm)	SA-SE/LS	1915	1915	1915	--	2400	2400	2400	--	2905	2905	2905	3905	3905
C (mm)	SA-SE/LS	875	875	875	--	1150	1150	1150	--	1150	1150	1150	1150	1150
kg	SA-SE/LS	550	550	560	--	670	700	760	--	880	890	910	1190	1270
A (mm)	HA-HE/LS	1500	1500	--	1690	1690	1690	--	1880	1880	1880	1880	1880	1880
B (mm)	HA-HE/LS	1915	1915	--	2400	2400	2400	--	2905	2905	2905	2905	2905	2905
C (mm)	HA-HE/LS	875	875	--	1150	1150	1150	--	1150	1150	1150	1150	1150	1150
kg	HA-HE/LS	560	560	--	670	690	720	--	1060	1060	1070	1120	1160	1240
A (mm)	HA-HE/XL	1500	1500	--	1690	1690	1690	--	1880	1880	1880	1880	1880	1880
B (mm)	HA-HE/XL	1915	1915	--	2400	2400	2400	--	2905	2905	2905	2905	2905	2905
C (mm)	HA-HE/XL	875	875	--	1150	1150	1150	--	1150	1150	1150	1150	1150	1150
kg	HA-HE/XL	570	570	--	680	710	740	--	1080	1080	1090	1140	1180	1260

LHA SA-SE/HH-RV	LHA HA-HE /HH-RV	P2S/P2U	1402	1602	1802	2002	2302	2502	2504	3004	3204	3504	4004	4504	5004
Flow switch			●	●	●	●	●	●	●	●	●	●	●	●	●
"Floating frame" Technology - LS Version			-	-	-	-	-	-	-	-	-	-	-	-	-
"Floating frame" Technology - XL Version			●	●	●	●	●	●	●	●	●	●	●	●	●
E.C. fans - SA versions	VECE		-	-	-	-	-	-	-	-	-	-	-	-	-
E.C. fans - SE versions	VECE		●	●	●	●	●	●	●	●	●	●	●	●	●
E.C. fans - HA versions	VECE		-	-	-	-	-	-	-	-	-	-	-	-	-
E.C. fans - HE versions	VECE		●	●	●	●	●	●	●	●	●	●	●	●	●
Condensate discharge drip tray with antifreeze heater	BRCA		○	○	○	○	○	○	○	○	○	○	○	○	○
Fans regulation by phase cut	DCCF		X	X	X	X	X	X	X	X	X	X	X	X	X
Antifreeze kit for 2 pipe units	RAEV2		○	○	○	○	○	○	○	○	○	○	○	○	○
Electronic soft starter	DSSE		○	○	○	○	○	○	○	○	○	○	○	○	○
Serial interface card RS485	INSE		●	●	●	●	●	●	●	●	●	●	●	●	●
Rubber anti-vibration mountings	KAVG		○	○	○	○	○	○	○	○	○	○	○	○	○
Remote control panel	PCRL		○	○	○	○	○	○	○	○	○	○	○	○	○
Electronic expansion valve	VTEE		○	○	○	○	○	○	○	○	○	○	○	○	○
Cascade control system via RS485	SGRS		○	○	○	○	○	○	○	○	○	○	○	○	○
Hydraulic kit with one pump with tank	A1ZZU		○	○	○	○	○	○	○	○	○	○	○	○	○
Hydraulic kit with two pumps with tank	A2ZZU		○	○	○	○	○	○	○	○	○	○	○	○	○
Hydraulic kit with one pump without tank	A1NTU		○	○	○	○	○	○	○	○	○	○	○	○	○
Hydraulic kit with two pumps without tank	A2NTU		○	○	○	○	○	○	○	○	○	○	○	○	○

X Necessary for P2S version      ● Standard ○ Optional - Not available  
 Optional for P2U version

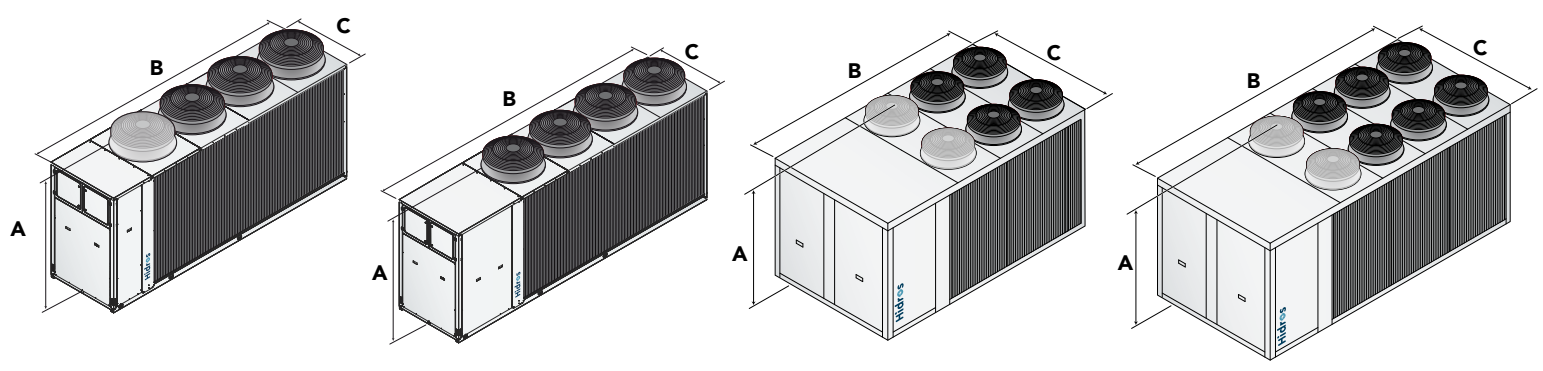

**SA/SE** 2302 - 2502

**SA/SE** 2504 - 3004 - 3204

**SA/SE** 3504 - 4004  
**HA/HE-LS/XL** 2504 - 3004 - 3204 - 3504

**SA/SE** 4504 - 5004  
**HA/HE-LS/XL** 4004 - 4504 - 5004

		1402	1602	1802	2002	2302	2502	2504	3004	3204	3504	4004	4504	5004
A (mm)	SA-SE/LS	1880	1880	2270	2270	2310	2310	2310	2310	2310	2350	2350	2380	2380
B (mm)	SA-SE/LS	3905	3905	3905	3905	4505	4505	5300	5300	5300	4205	4205	4810	4810
C (mm)	SA-SE/LS	1150	1150	1150	1150	1150	1150	1150	1150	1150	2210	2210	2210	2210
kg	SA-SE/LS	1320	1360	1690	1710	1990	2040	2500	2540	2620	3220	3270	3600	3700
A (mm)	HA-HE/LS	1880	1880	1880	1880	2270	2270	2350	2350	2350	2350	2380	2380	2380
B (mm)	HA-HE/LS	3905	3905	3905	3905	3905	3905	4205	4205	4205	4205	4805	4810	4810
C (mm)	HA-HE/LS	1150	1150	1150	1150	1150	1150	2210	2210	2210	2210	2210	2210	2210
kg	HA-HE/LS	1560	1580	1600	1620	1790	1820	3170	3220	3270	3320	3660	3720	3780
A (mm)	HA-HE/XL	1880	1880	1880	1880	2270	2270	2350	2350	2350	2350	2380	2380	2380
B (mm)	HA-HE/XL	3905	3905	3905	3905	3905	3905	4205	4205	4205	4205	4805	4810	4810
C (mm)	HA-HE/XL	1150	1150	1150	1150	1150	1150	2210	2210	2210	2210	2210	2210	2210
kg	HA-HE/XL	1590	1610	1630	1650	1820	1850	3220	3270	3320	3370	3710	3770	3830

# LHE

## HIGH EFFICIENCY AIR TO WATER HEAT PUMPS WITH LOW GWP REFRIGERANT

Heating power from 45 kW to 457 kW

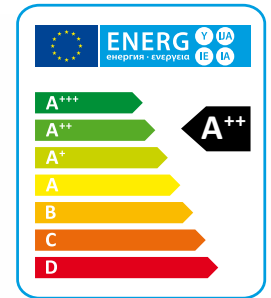

LHE high-efficiency air/water heat pumps are particularly suitable for applications where maximum efficiency in heating mode and a low noise level are required. The units are specifically designed to provide the best efficiency in heating mode; they can operate at outside temperatures down to -20°C and produce water up to a temperature of 60°C.

All sizes are supplied with reverse cycle valve used for winter defrost; the RV versions are also able to produce cold water in summer period (not available for HH versions).

### VERSIONI

- HH** Heating only.
- RV** Reversible heating/cooling.
- HA** High efficiency, AC fans.
- HE** High efficiency, EC fans.
- LS** Low noise.
- XL** Super low noise.
- P2U** 2 pipe systems without domestic hot water production.
- P2S** 2 pipe systems with domestic hot water production by external 3 way valve.





Reversible heating/cooling version (RV)

HA/XL/HH-RV P2U		452	512	682	752	912	1102	1152	1352	1502	1612
Heating capacity (EN14511) <sup>(1)</sup>	kW	45,2	51,0	67,6	73,6	89,9	102,0	112,0	133,0	148,0	160,0
Total input power (EN14511) <sup>(1)</sup>	kW	11,5	13,0	16,2	18,2	22,2	25,0	27,6	32,8	37,9	39,9
COP (EN14511) <sup>(1)</sup>	W/W	3,93	3,92	4,17	4,04	4,05	4,08	4,06	4,05	3,91	4,01
Energy Class <sup>(2)</sup>		A++	A++	A++	A++	A+	A++	A++	A++	A++	A++
SCOP <sup>(2)</sup>	kWh/kWh	3,88	3,97	4,07	4,02	3,79	4,12	4,14	3,98	3,95	4,02
η <sub>s,h</sub> <sup>(2)</sup>	%	152	156	160	158	149	162	163	156	155	158
Cooling capacity (EN14511) <sup>(3)</sup>	kW	37,0	42,5	56,1	59,0	75,3	84,5	93,3	111,0	122,0	132,0
Total input power (EN14511) <sup>(3)</sup>	kW	14,3	16,7	21,7	25,6	26,7	31,0	35,8	38,3	45,4	49,6
EER (EN14511) <sup>(3)</sup>	W/W	2,59	2,54	2,59	2,30	2,82	2,73	2,61	2,90	2,69	2,66
TER (EN14511) <sup>(4)</sup>	W/W	5,58	5,78	6,04	5,82	5,98	5,94	6,04	5,91	5,80	5,92
Sound power <sup>(5)</sup>	dB (A)	72	72	72	73	75	76	78	80	81	81
Sound pressure <sup>(6)</sup>	dB (A)	40	40	40	41	43	44	46	48	49	49
HE/XL/HH-RV P2U		452	512	682	752	912	1102	1152	1352	1502	1612
Heating capacity (EN14511) <sup>(1)</sup>	kW	44,6	51,2	68,2	74,1	89,4	101,0	111,0	132,0	148,0	158,0
Total input power (EN14511) <sup>(1)</sup>	kW	11,0	12,8	16,1	18,1	20,7	23,6	26,2	30,6	35,3	37,5
COP (EN14511) <sup>(1)</sup>	W/W	4,05	4,00	4,24	4,09	4,32	4,28	4,24	4,31	4,19	4,21
Energy Class <sup>(2)</sup>		A++	A++	A++	A++	A++	A++	A++	A++	A++	A++
SCOP <sup>(2)</sup>	kWh/kWh	4,00	4,02	4,19	4,13	4,24	4,35	4,39	4,29	4,27	4,24
η <sub>s,h</sub> <sup>(2)</sup>	%	157	158	165	162	167	171	173	169	168	167
Cooling capacity (EN14511) <sup>(3)</sup>	kW	35,9	42,3	56,0	59,4	73,3	82,1	90,6	108,0	119,0	129,0
Total input power (EN14511) <sup>(3)</sup>	kW	14,2	16,5	21,5	25,0	26,1	30,7	35,4	37,4	44,3	48,6
EER (EN14511) <sup>(3)</sup>	W/W	2,53	2,56	2,60	2,38	2,81	2,67	2,56	2,89	2,69	2,65
TER (EN14511) <sup>(4)</sup>	W/W	6,19	5,78	6,04	5,82	5,98	5,94	6,04	5,91	5,80	5,92
Sound power <sup>(5)</sup>	dB (A)	78	76	76	77	81	83	84	85	84	86
Sound pressure <sup>(6)</sup>	dB (A)	46	44	44	45	49	51	52	53	52	54
Power supply	V/Ph/Hz	400/3/50	400/3/50	400/3/50	400/3/50	400/3/50	400/3/50	400/3/50	400/3/50	400/3/50	400/3/50
Compressors / Circuits	n° / n°	2 / 1	2 / 1	2 / 1	2 / 1	2 / 1	2 / 1	2 / 1	2 / 1	2 / 1	2 / 1
Fans	n°	2	2	2	2	2	2	2	3	3	3
Refrigerant		R454B	R454B	R454B	R454B	R454B	R454B	R454B	R454B	R454B	R454B
Refrigerant charge	kg	10,0	14,5	19,0	19,0	27,0	27,0	27,0	36,0	36,0	36,0
Global warming potential (GWP)		466	466	466	466	466	466	466	466	466	466
Equivalent CO <sub>2</sub> charge	t	4,7	6,8	8,9	8,9	12,6	12,6	12,6	16,8	16,8	16,8
Water tank volume	l	140	140	300	300	300	300	300	500	500	500

HA/XL/HH-RV P2U		1792	2012	2304	2312	2654	2954	3214	3514	3954	4454
Heating capacity (EN14511) <sup>(1)</sup>	kW	181,0	200,0	229,0	227,0	267,0	300,0	320,0	365,0	407,0	456,0
Total input power (EN14511) <sup>(1)</sup>	kW	44,2	49,3	55,9	55,0	66,8	76,6	80,9	92,0	101,0	113,0
COP (EN14511) <sup>(1)</sup>	W/W	4,10	4,06	4,10	4,13	4,00	3,92	3,96	3,97	4,03	4,04
Energy Class <sup>(2)</sup>		A++	A++	A++	A++	A+	A+	A++	A++	A++	A++
SCOP <sup>(2)</sup>	kWh/kWh	4,09	4,09	3,86	4,09	3,82	3,79	3,89	3,88	3,85	3,84
η <sub>s,h</sub> <sup>(2)</sup>	%	161	161	151	161	150	149	153	152	151	151
Cooling capacity (EN14511) <sup>(3)</sup>	kW	154,0	171,0	191	188,0	222,0	247,0	263,0	294,0	342,0	374,0
Total input power (EN14511) <sup>(3)</sup>	kW	58,9	64,0	72,4	72,2	80,1	94,0	103,0	121,0	128,0	145,0
EER (EN14511) <sup>(3)</sup>	W/W	2,61	2,67	2,65	2,60	2,77	2,63	2,55	2,43	2,67	2,58
TER (EN14511) <sup>(4)</sup>	W/W	6,20	6,11	6,01	6,11	5,89	5,77	5,83	5,81	6,76	6,76
Sound power <sup>(5)</sup>	dB (A)	81	83	81	84	83	84	84	84	86	87
Sound pressure <sup>(6)</sup>	dB (A)	49	51	48	51	51	52	52	51	53	54
HE/XL/HH-RV P2U		1792	2012	2304	2312	2654	2954	3214	3514	3954	4454
Heating capacity (EN14511) <sup>(1)</sup>	kW	179,0	199,0	222,0	225,0	260,0	291,0	312,0	352,0	395,0	434,0
Total input power (EN14511) <sup>(1)</sup>	kW	42,5	47,0	52,9	52,9	62,0	71,5	76,0	86,8	95,6	107,0
COP (EN14511) <sup>(1)</sup>	W/W	4,21	4,23	4,20	4,25	4,19	4,07	4,11	4,06	4,13	4,06
Energy Class <sup>(2)</sup>		A++	A++	A++	A++	A++	A++	A++	A++	A++	A++
SCOP <sup>(2)</sup>	kWh/kWh	4,33	4,33	4,37	4,31	4,14	4,18	4,18	4,19	4,20	4,07
η <sub>s,h</sub> <sup>(2)</sup>	%	170	170	172	169	163	164	164	165	165	160
Cooling capacity (EN14511) <sup>(3)</sup>	kW	150,0	165,0	186,0	181,0	218,0	242,0	257,0	284,0	335,0	364,0
Total input power (EN14511) <sup>(3)</sup>	kW	58,7	64,6	71,3	73,4	77,0	91,2	101,0	120,0	125,0	144,0
EER (EN14511) <sup>(3)</sup>	W/W	2,56	2,55	2,61	2,47	2,83	2,65	2,54	2,37	2,68	2,53
TER (EN14511) <sup>(4)</sup>	W/W	6,20	6,11	6,01	6,11	5,89	5,77	5,83	5,81	6,76	6,89
Sound power <sup>(5)</sup>	dB (A)	87	90	87	89	87	87	89	89	92	89
Sound pressure <sup>(6)</sup>	dB (A)	55	57	55	56	55	54	56	57	59	56
Power supply	V/Ph/Hz	400/3/50	400/3/50	400/3/50	400/3/50	400/3/50	400/3/50	400/3/50	400/3/50	400/3/50	400/3/50
Compressors / Circuits	n° / n°	2 / 1	2 / 1	4 / 2	2 / 1	4 / 2	4 / 2	4 / 2	4 / 2	4 / 2	4 / 2
Fans	n°	3	3	4	3	6	6	6	6	8	8
Refrigerant		R454B	R454B	R454B	R454B	R454B	R454B	R454B	R454B	R454B	R454B
Refrigerant charge	kg	45,0	45,0	60,0	60,0	72,0	72,0	72,0	90,0	100,0	100,0
Global warming potential (GWP)		466	466	466	466	466	466	466	466	466	466
Equivalent CO <sub>2</sub> charge	t	20,9	20,9	27,9	27,9	33,6	33,6	33,6	33,6	41,9	46,6
Water tank volume	l	500	500	500	500	500	500	500	500	500	500

Performances are referred to the following conditions:

- (1) Heating: Ambient temperature 7°C DB, 6°C WB, water temperature 30/35°C.
- (2) Average conditions, low temperature, variable - Reg EU 811/2013
- (3) Cooling: ambient air temperature 35°C, evaporator water temperature in/out 12/7 °C (only rv versions).
- (4) TER: Total Energy Ratio - cold circuit 12/7°C, hot circuit 30/35°C.
- (5) Sound power level in accordance with ISO 3744.
- (6) Sound pressure level at 10 mt from the unit in free field conditions in accordance with ISO 3744.





## COMPONENTS

### FRAME

All units are made from hot-galvanised sheet steel, painted with polyurethane powder enamel and stoved at 180°C to provide maximum protection against corrosion. The frame is self-supporting with removable panels. All screws and rivets used are made from stainless steel. The standard colour of the units is RAL9018.

### REFRIGERANT CIRCUIT

The refrigerant circuit is assembled using internationally recognised brand name components with all brazing and welding being performed in accordance with ISO 97/23. The refrigerant utilised is R454B. The refrigerant circuit includes: sight glass, filter drier, electronic expansion valves, 4 way reversing valve, check valves, liquid receiver, liquid separator, schrader valves for maintenance and control, pressure safety device (for compliance with PED regulations).

### COMPRESSORS

The compressors are scroll type, with crankcase resistance and thermal protection, installed in a separate compartment from the airflow in order to reduce noise. When the unit is on stand-by mode, the crankcase heater is always powered. Through the unit's front panel, it is possible to inspect and repair the compressors even when the unit is running.

The compressors used are tandem type. This solution allows a significantly higher efficiency with partial loads compared to the option with independent refrigerant circuits. The control system constantly monitors the discharge temperature of the single compressors.

### SOURCE HEAT EXCHANGER

The source heat exchanger is made from 3/8" copper pipes and 0,1mm at least thick aluminium fins with the tubes being mechanically expanded into the aluminium fins in order to maximise heat transfer. Furthermore, the design guarantees a low air side pressure drop thus enabling the use of low rotation speed (and hence low noise) fans. All heat exchangers are supplied standard with fins hydrophilic coating "Blue Fins".

### USER CIRCUIT HEAT EXCHANGERS

The user heat exchanger is a braze welded, plate type heat exchanger, manufactured from AISI 316 stainless steel. The use of this type of exchanger results in a massive reduction of the refrigerant charge of the unit compared to a traditional shell-in-tube type. A further advantage is a reduction in the overall dimensions of the unit. The exchangers are factory insulated with flexible close cell material and can be fitted with an antifreeze heater (accessory). Each exchanger is fitted with a temperature sensor on the discharge water side for antifreeze protection.

### FANS

The fans are direct drive axial type with aerofoil blades, are statically and dynamically balanced and are supplied complete with a safety fan guard complying with the requirements of EN 60335. They are fixed to the unit frame via rubber anti-vibration mountings. The electric motors, in HA versions are 6 poles type and a phase-cut regulator controls their speed of rotation to increase energy efficiency and allow them to be used over a wider operating range. In the HE versions, the fans are electronic type, with permanent magnet motors with an integrated driver that modulates the speed of rotation. The motors are fitted with integrated thermal overload protection and have a moisture protection rating of IP 54.

### MICROPROCESSORS

All units are supplied as standard with microprocessor controls. The microprocessor controls the following functions: control of the water temperature, antifreeze protection, compressor timing, compressor automatic starting sequence (For multiple compressors), alarm reset.

The control panel is supplied with display showing all operational icons. The microprocessor is set for automatic defrost (when operating in severe ambient conditions) and for summer/ winter change over. The control also manages the integration with other heating sources (electric heaters, boilers, solar panels etc) and both the heating circuit pump and the domestic hot water circuit pump. If required (available as an option), the microprocessor can be configured in order for it to connect to a site BMS system thus enabling remote control and management.

### ELECTRIC ENCLOSURE

The enclosure is manufactured in order to comply with the requirements of the electromagnetic compatibility standards 2014/35/UE and 2014/30/UE. Access to the enclosure is achieved by removing the front panel of the unit. The following components are supplied as standard on all units: main switch, a sequence relay that disables the power supply in the event that the phase sequence is incorrect (scroll compressors can be damaged if they rotate in the wrong direction), thermal overloads (protection of pumps and fans), compressor fuses, control circuit automatic breakers, compressor contactors, fan contactors and pump contactors. The terminal board has volt free contacts for remote ON-OFF, Summer/ winter change over (heat pumps only) and general alarm.

### CONTROL AND PROTECTION DEVICES

All units are standardly equipped with several control and safety devices: water return temperature sensor, installed on the water return pipe of the system, and anti-freeze probe, installed on the water supply pipe to the system high-pressure switch with automatic reset. There are also included a low-pressure automatic reset, pressure transducer (used to optimize the defrosting cycle and modulate the rotation speed of the fans according to external conditions), Freon side safety device, compressor thermal protection, fan thermal protection, flow switch, and external air compensation probe.

### LEAK DETECTOR

When the unit is powered ON, the sensor is warmed up/initialised (duration approx. 1min.).

During this period, the LEDs inside the sensor blink, the refrigerant leakage alarm is notified and the 24Vac auxiliary circuit is switched off. After this period, if in the absence of any further feedback from the sensor, the PLC control is powered up and the unit is ready to operate. If refrigerant leaks occur, the sensor is activated and the power supply to the control PLC is immediately switched off until the sensor indicates the refrigerant is still present.

## VERSION

### HA/XL HE/XL Super low noise version

All XL super silenced units are supplied equipped with a special vibration-damping system consisting of a floating basement placed upon the unit's frame, through the interposition of high-damping steel springs.

The compressors are housed on this floating base and are in turn fixed by means of rubber anti-vibration supports.

The enclosure is manufactured from galvanized steel sandwich panels that have a micro-perforated inner skin and a core of 30 mm thick, high density (25 kg/m<sup>3</sup>) soundproofing mat. The entire arrangement provides a double damping system and acoustic attenuation. The compressor refrigerant pipes are connected to the refrigerant circuit through "anaconda" flexible connections. Flexible connections are also used on the water pipework within the unit. The combination of these systems results in an overall noise reduction in the region of 6-8 dB(A) compared to units in standard configuration.

### HH Version

HH heating only versions are available in the P2U and P2S configuration only.

### RV Version

This version uses 2 hydraulic connections and is able to produce hot water in winter and cold water in summer. The unit is combined with a 2-pipe system.

### HA Version

High efficiency version, according to current standard. Unit equipped with AC fans.

### HE Version

High efficiency version, according to current standard. Unit equipped with EC fans.

### LS Version

This version includes the complete acoustic insulation of the unit with compressor jackets and insulating material made with high density media and the interposition of heavy bitumen layer.

### P2U Version

This is a two pipe version that can produce hot water for heating (HH heating only) and hot or cold water in the RV version. The RV is used with two pipe water based change-over systems. It is not able to produce domestic hot water.

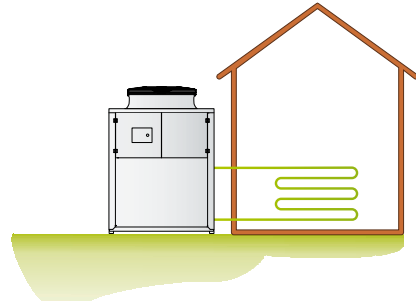

### P2S Version

This is a two pipe version that can, in addition to producing hot water for heating and cold water for cooling, also generate domestic hot water. The controller has dual heating set points (heating and DHW) and can also control a three port diverting valve that directs the DHW to the cylinder. DHW production has priority irrespective of the mode of operation of the unit. The unit is normally used with two pipe water based change-over systems.

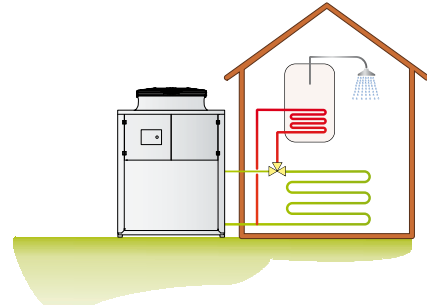

## OPERATION LIMITS

(HA/HE versions)

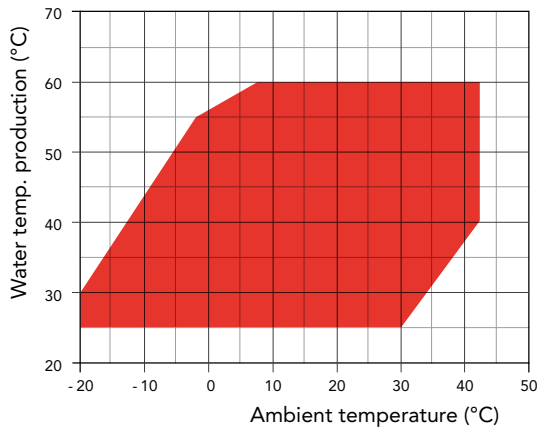

■ Heating mode

(RV versions Only)

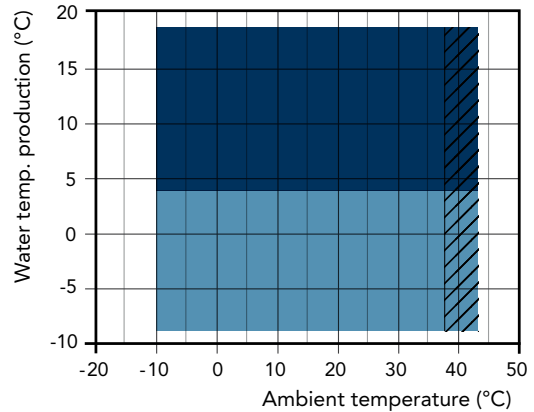

■ Cooling mode

■ Glycol set-up

Possible noise increase for XL versions

## ACCESSORIES

LHE HA-HE /HH-RV		452	512	682	752	912	1102	1152	1352	1502	1612
Flow switch		●	●	●	●	●	●	●	●	●	●
Floating frame technology - LS version		-	-	-	-	-	-	-	-	-	-
Floating frame technology - XL version		●	●	●	●	●	●	●	●	●	●
Hydraulic kit with storage tank and one low-pressure pump	A1LLU	○	○	○	○	○	○	○	○	○	○
Hydraulic kit with one low-pressure pump	A1LPU	○	○	○	○	○	○	○	○	○	○
Hydraulic kit with one pump without tank - user circuit	A1NTU	○	○	○	○	○	○	○	○	○	○
User circuit hydraulic kit, one inverter pump, no tank	A1VSU	○	○	○	○	○	○	○	○	○	○
User circuit hydraulic kit + inverter centrifugal pump	A1VVU	○	○	○	○	○	○	○	○	○	○
Integrated hydraulic kit 1 pump + Water tank	A1ZZU	○	○	○	○	○	○	○	○	○	○
Hydraulic kit with two pumps without tank - user circuit	A2NTU	○	○	○	○	○	○	○	○	○	○
Integrated hydraulic kit 2 pumps + Water tank	A2ZZU	○	○	○	○	○	○	○	○	○	○
Condensate discharge drip tray with antifreeze heater	BRCA	○	○	○	○	○	○	○	○	○	○
4-connection tank and low-pressure pump	BUF4A	○	○	○	○	○	○	○	○	○	○
Fans regulation by phase cut (HA version)	DCCF	●	●	●	●	●	●	●	●	●	●
Refrigerant leakage detector	DFR	●	●	●	●	●	●	●	●	●	●
Electronic soft starter	DSSE	○	○	○	○	○	○	○	○	○	○
Double safety valve	DSV	○	○	○	○	○	○	○	○	○	○
Coil protection grid	GBPE	○	○	○	○	○	○	○	○	○	○
WIFI Application	HIPRO.web	○	○	○	○	○	○	○	○	○	○
Display	HMI.PRO	●	●	●	●	●	●	●	●	●	●
Serial interface card RS485	INSE	●	●	●	●	●	●	●	●	●	●
Rubber vibration dampers	KAVG	○	○	○	○	○	○	○	○	○	○
Spring vibration dampers	KAVM	○	○	○	○	○	○	○	○	○	○
COP internal optimizer kit	KCOP	○	○	○	○	○	○	○	○	○	○
Lifting rings kit	KGS	●	●	●	●	●	●	●	●	●	●
Safety valve ducting aid kit	KCSV	●	●	●	●	●	●	●	●	●	●
Double safety valve ducting aid kit	KCDV	○	○	○	○	○	○	○	○	○	○
Tank antifreeze kit	KPSU	○	○	○	○	○	○	○	○	○	○
User antifreeze kit	KPU	○	○	○	○	○	○	○	○	○	○
Victaulic kit	KVICT	-	-	-	-	-	-	-	-	-	-
Pressure gauges	MAML	○	○	○	○	○	○	○	○	○	○
Remote control panel	PCRL	○	○	○	○	○	○	○	○	○	○
Shut-off valve on compressor discharging side	RDCO	○	○	○	○	○	○	○	○	○	○
Cascade control system via RS485	SGRS	○	○	○	○	○	○	○	○	○	○
DHW probe kit	SOND1	●	●	●	●	●	●	●	●	●	●
E.C. fans - HA versions	VECE	-	-	-	-	-	-	-	-	-	-
E.C. fans - HE versions	VECE	●	●	●	●	●	●	●	●	●	●
Electronic expansion valve	VTEE	●	●	●	●	●	●	●	●	●	●

● Standard ○ Optional – Not available

LHE HA-HE /HH-RV		1792	2012	2304	2312	2654	2954	3214	3514	3954	4454
Flow switch		●	●	●	●	●	●	●	●	●	●
Floating frame technology - LS version		-	-	-	-	-	-	-	-	-	-
Floating frame technology - XL version		●	●	●	●	●	●	●	●	●	●
Hydraulic kit with storage tank and one low-pressure pump	A1LLU	○	○	○	○	○	○	○	○	○	○
Hydraulic kit with one low-pressure pump	A1LPU	○	○	○	○	○	○	○	○	○	○
Hydraulic kit with one pump without tank - user circuit	A1NTU	○	○	○	○	○	○	○	○	○	○
User circuit hydraulic kit, one inverter pump, no tank	A1VSU	○	○	○	○	○	○	○	○	○	○
User circuit hydraulic kit + inverter centrifugal pump	A1VVU	○	○	○	○	○	○	○	○	○	○
Integrated hydraulic kit 1 pump + Water tank	A1ZZU	○	○	○	○	○	○	○	○	○	○
Hydraulic kit with two pumps without tank - user circuit	A2NTU	○	○	○	○	○	○	○	○	○	○
Integrated hydraulic kit 2 pumps + Water tank	A2ZZU	○	○	○	○	○	○	○	○	○	○
Condensate discharge drip tray with antifreeze heater	BRCA	○	○	○	○	○	○	○	○	○	○
4-connection tank and low-pressure pump	BUF4A	○	○	○	○	○	○	○	○	○	○
Fans regulation by phase cut (HA version)	DCCF	●	●	●	●	●	●	●	●	●	●
Refrigerant leakage detector	DFR	●	●	●	●	●	●	●	●	●	●
Electronic soft starter	DSSE	○	○	○	○	○	○	○	○	○	○
Double safety valve	DSV	○	○	○	○	○	○	○	○	○	○
Coil protection grid	GBPE	○	○	○	○	○	○	○	○	○	○
WIFI Application	HIPRO.web	○	○	○	○	○	○	○	○	○	○
Display	HMI.PRO	●	●	●	●	●	●	●	●	●	●
Serial interface card RS485	INSE	●	●	●	●	●	●	●	●	●	●
Rubber vibration dampers	KAVG	○	○	○	○	○	○	○	○	○	○
Spring vibration dampers	KAVM	○	○	○	○	○	○	○	○	○	○
COP internal optimizer kit	KCOP	○	○	○	○	○	○	○	○	○	○
Lifting rings kit	KGS	●	●	●	●	●	●	●	●	●	●
Safety valve ducting aid kit	KCSV	●	●	●	●	●	●	●	●	●	●
Double safety valve ducting aid kit	KCDV	○	○	○	○	○	○	○	○	○	○
Tank antifreeze kit	KPSU	○	○	○	○	○	○	○	○	○	○
User antifreeze kit	KPU	○	○	○	○	○	○	○	○	○	○
Victaulic kit	KVICT	●	●	●	●	●	●	●	●	●	●
Pressure gauges	MAML	○	○	○	○	○	○	○	○	○	○
Remote control panel	PCRL	○	○	○	○	○	○	○	○	○	○
Shut-off valve on compressor discharging side	RDCO	○	○	○	○	○	○	○	○	○	○
Cascade control system via RS485	SGRS	○	○	○	○	○	○	○	○	○	○
DHW probe kit	SOND1	●	●	●	●	●	●	●	●	●	●
E.C. fans - HA versions	VECE	-	-	-	-	-	-	-	-	-	-
E.C. fans - HE versions	VECE	●	●	●	●	●	●	●	●	●	●
Electronic expansion valve	VTEE	●	●	●	●	●	●	●	●	●	●

● Standard ○ Optional - Not available



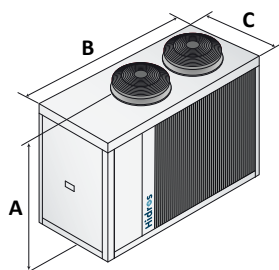

F1

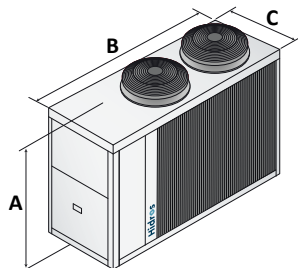

F2

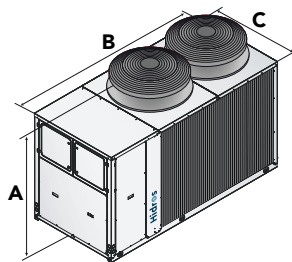

F3

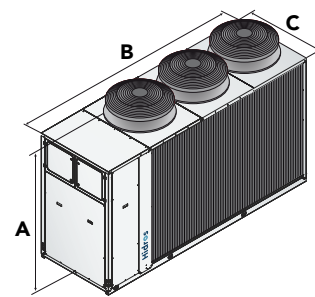

F4

	452	512	682	752	912	1102	1152	1352	1502	1612
A (mm)	1673	1673	1839	1839	1918	1918	1918	1918	1918	1918
B (mm)	2400	2400	3000	3000	3000	3000	3000	4295	4295	4295
C (mm)	1265	1265	1265	1265	1265	1265	1265	1265	1265	1265
Kg	650	658	884	890	1100	1108	1110	1688	1714	1722
<b>FRAME</b>	<b>F1</b>	<b>F1</b>	<b>F2</b>	<b>F2</b>	<b>F3</b>	<b>F3</b>	<b>F3</b>	<b>F4</b>	<b>F4</b>	<b>F4</b>

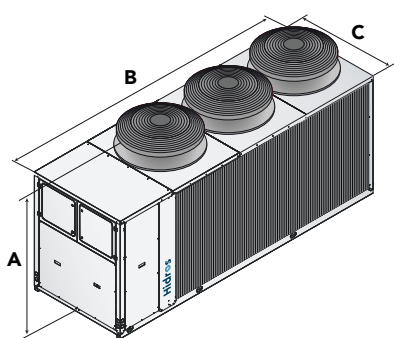

F5

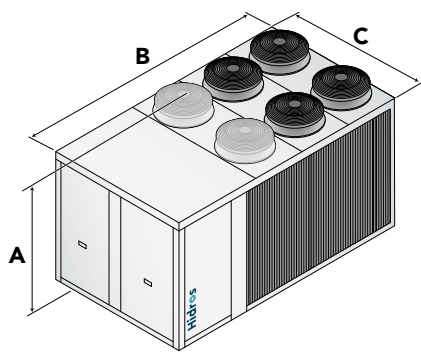

F6

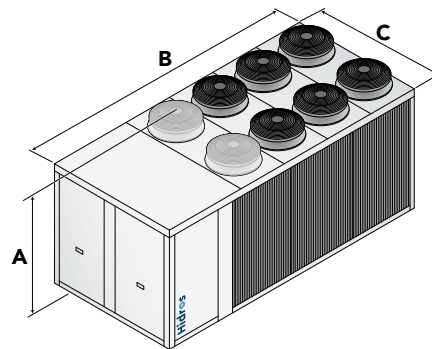

F7

	1792	2012	2304	2312	2654	2954	3214	3514	3954	4454
A (mm)	1918	2287	2378	2287	2378	2378	2378	2378	2378	2378
B (mm)	4295	4296	4515	4296	4515	4515	4515	4515	5557	5557
C (mm)	1265	1265	2310	1265	2310	2310	2310	2310	2310	2310
Kg	1776	1762	1778	3262	3348	3438	3438	3508	3658	3686
<b>FRAME</b>	<b>F4</b>	<b>F5</b>	<b>F6</b>	<b>F5</b>	<b>F6</b>	<b>F6</b>	<b>F6</b>	<b>F6</b>	<b>F7</b>	<b>F7</b>

# LZT

## HIGH EFFICIENCY AIR TO WATER HEAT PUMPS WITH E.V.I. COMPRESSORS

Heating power from 23 kW to 218 kW

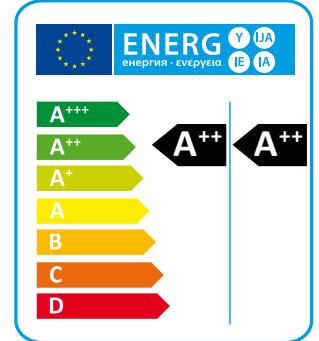

The LZT series of high efficiency heat pumps has been specifically designed for use with radiant floor heating systems or those applications where it is necessary to have maximum efficiency when heating.

They have been optimized on heating mode, are able to produce water up to 65°C and can operate down to -20°C ambient temperature.

All versions are supplied with reverse cycle valve used for winter defrost; the HH version is suitable for use in those countries that have support schemes for use of heat pump technology for heating. The RV versions are also able to produce cold water. The HH heating only versions is factory set and locked to operate only in heating mode whilst.

The noise in XL and NN versions is extremely low thanks to the use of a special floating vibration damping system which allows a noise reduction of about 6-8 dB(A).

### VERSIONS

- HH** Heating only.
- RV** Reversible heating/cooling.
- SA** Standard efficiency, AC fans.
- SE** Standard efficiency, EC fans.
- HA** High efficiency, AC fans.
- HE** High efficiency, EC fans.
- LS** Low noise.
- XL** Super low noise.
- NN** Ultra low noise.
- P2U** 2 pipe systems without domestic hot water production.
- P2S** 2 pipe systems with domestic hot water production by external 3 way valve.

Heating only version (HH)

SA/LS/HH - P2S/P2U		242	292	432	492	592	752	852
Heating capacity (EN14511) <sup>(1)</sup>	kW	23,7	28,3	42,1	50,9	55,0	67,8	74,5
Total input power (EN14511) <sup>(1)</sup>	kW	5,5	6,8	10,3	12,3	13,4	16,3	18,3
COP (EN14511) <sup>(1)</sup>	W/W	4,31	4,16	4,11	4,14	4,12	4,16	4,07
Energy Class in low temperature <sup>(2)</sup>		A+	A+	A+	A+	A+	A+	A+
SCOP low temperature <sup>(2)</sup>	kWh/kWh	3,75	3,77	3,39	3,33	3,49	3,70	3,62
η <sub>s,h</sub> low temperature <sup>(2)</sup>	%	147	148	133	130	137	145	142
Energy Class in medium temperature <sup>(2)</sup>		A+	A+	A+	A+	A+	A+	A+
SCOP medium temperature <sup>(2)</sup>	kWh/kWh	3,04	3,07	2,89	2,87	2,93	3,06	3,03
η <sub>s,h</sub> medium temperature <sup>(2)</sup>	%	119	120	112	112	114	119	118
Sound power <sup>(3)</sup>	dB (A)	78	78	79	80	80	80	80
Sound pressure <sup>(4)</sup>	dB (A)	46	46	47	48	48	48	48
SE/LS/HH - P2S/P2U		242	292	432	492	592	752	852
Heating capacity (EN14511) <sup>(1)</sup>	kW	23,7	28,3	42,1	50,5	55,2	67,8	74,7
Total input power (EN14511) <sup>(1)</sup>	kW	5,3	6,7	9,9	12,8	13,8	16,1	18,2
COP (EN14511) <sup>(1)</sup>	W/W	4,47	4,22	4,25	3,95	4,00	4,21	4,10
Energy Class in low temperature <sup>(2)</sup>		A++	A++	A+	A+	A+	A+	A+
SCOP low temperature <sup>(2)</sup>	kWh/kWh	3,95	3,87	3,58	3,45	3,59	3,79	3,68
η <sub>s,h</sub> low temperature <sup>(2)</sup>	%	155	152	140	135	141	149	144
Energy Class in medium temperature <sup>(2)</sup>		A+	A+	A+	A+	A+	A+	A+
SCOP medium temperature <sup>(2)</sup>	kWh/kWh	3,17	3,13	3,02	2,99	3,02	3,13	3,10
η <sub>s,h</sub> medium temperature <sup>(2)</sup>	%	124	122	118	116	118	122	121
Sound power <sup>(3)</sup>	dB (A)	78	78	79	80	80	80	80
Sound pressure <sup>(4)</sup>	dB (A)	46	46	47	48	48	48	48
Power supply	V/Ph/Hz	400/3+N/50	400/3+N/50	400/3/50	400/3/50	400/3/50	400/3/50	400/3/50
Compressors / Circuits	n° / n°	2 / 1	2 / 1	2 / 1	2 / 1	2 / 1	2 / 1	2 / 1
Fans	n°	1	1	2	2	2	2	2
Refrigerant		R410A	R410A	R410A	R410A	R410A	R410A	R410A
Refrigerant charge	kg	10,0	10,0	10,0	12,0	12,0	18,0	19,0
Global warming potential (GWP)		2088	2088	2088	2088	2088	2088	2088
Equivalent CO <sub>2</sub> charge	t	20,88	20,88	20,88	25,05	25,05	37,58	39,67
Water tank volume	l	100	100	100	100	100	300	300

SA/LS/HH - P2S/P2U		1002	1202	1454	1654	1854	2154
Heating capacity (EN14511) <sup>(1)</sup>	kW	88,5	102,5	145,3	162,9	180,2	205,4
Total input power (EN14511) <sup>(1)</sup>	kW	21,1	25,8	35,2	41,2	43,6	52,9
COP (EN14511) <sup>(1)</sup>	W/W	4,21	3,98	4,13	3,96	4,13	3,88
Energy Class in low temperature <sup>(2)</sup>		A+	A+	A+	A+	A+	A+
SCOP low temperature <sup>(2)</sup>	kWh/kWh	3,61	3,60	3,44	3,42	3,43	3,42
η <sub>s,h</sub> low temperature <sup>(2)</sup>	%	141	141	135	134	134	134
Energy Class in medium temperature <sup>(2)</sup>		A+	A+	A+	A+	A+	A+
SCOP medium temperature <sup>(2)</sup>	kWh/kWh	3,01	2,99	2,85	2,90	2,92	2,95
η <sub>s,h</sub> medium temperature <sup>(2)</sup>	%	117	117	111	113	114	115
Sound power <sup>(3)</sup>	dB (A)	80	80	87	87	88	89
Sound pressure <sup>(4)</sup>	dB (A)	48	48	55	55	56	57
SE/LS/HH - P2S/P2U		1002	1202	1454	1654	1854	2154
Heating capacity (EN14511) <sup>(1)</sup>	kW	88,2	102,5	146,0	164,3	181,3	208,1
Total input power (EN14511) <sup>(1)</sup>	kW	20,7	25,4	33,6	39,03	41,91	50,66
COP (EN14511) <sup>(1)</sup>	W/W	4,26	4,03	4,35	4,21	4,33	4,11
Energy Class in low temperature <sup>(2)</sup>		A+	A+	A+	A+	A+	A+
SCOP low temperature <sup>(2)</sup>	kWh/kWh	3,69	3,70	3,63	3,57	3,69	3,63
η <sub>s,h</sub> low temperature <sup>(2)</sup>	%	145	145	142	140	145	142
Energy Class in medium temperature <sup>(2)</sup>		A+	A+	A+	A+	A+	A+
SCOP medium temperature <sup>(2)</sup>	kWh/kWh	3,10	3,06	2,95	2,99	3,06	3,07
η <sub>s,h</sub> medium temperature <sup>(2)</sup>	%	121	120	115	117	120	120
Sound power <sup>(3)</sup>	dB (A)	80	80	86	87	88	89
Sound pressure <sup>(4)</sup>	dB (A)	48	48	54	55	56	57
Power supply	V/Ph/Hz	400/3/50	400/3/50	400/3/50	400/3/50	400/3/50	400/3/50
Compressors / Circuits	n° / n°	2 / 1	2 / 1	4/2	4/2	4/2	4/2
Fans	n°	3	4	4	4	4	4
Refrigerant		R410A	R410A	R410A	R410A	R410A	R410A
Refrigerant charge	kg	23,0	23,0	45,0	45,0	50,0	50,0
Global warming potential (GWP)		2088	2088	2088	2088	2088	2088
Equivalent CO <sub>2</sub> charge	t	48,02	48,02	93,96	93,96	104,40	104,40
Water tank volume	l	300	300	500	500	500	500

Performances are referred to the following conditions:

(1) Heating: Ambient temperature 7°C DB, 6°C WB, water temperature 30/35°C.

(2) Average conditions, variable - Reg EU 811/2013

(3) Sound power level in accordance with ISO 3744.

(4) Sound pressure level at 10 mt from the unit in free field conditions in accordance with ISO 3744.

Heating only version (HH)

HA/LS/HH - P2S/P2U		242	292	432	492	602	752	852
Heating capacity (EN14511) <sup>(1)</sup>	kW	23,8	29,4	41,6	51,2	58,0	66,7	80,8
Total input power (EN14511) <sup>(1)</sup>	kW	5,3	6,8	9,7	12,4	13,0	15,6	19,6
COP (EN14511) <sup>(1)</sup>	W/W	4,51	4,31	4,29	4,12	4,45	4,29	4,13
Energy Class in low temperature <sup>(2)</sup>		A++	A++	A+	A+	A++	A++	A+
SCOP low temperature <sup>(2)</sup>	kWh/kWh	3,96	3,89	3,63	3,553	3,94	3,95	3,76
η <sub>s,h</sub> low temperature <sup>(2)</sup>	%	155	153	142	139	155	155	147
Energy Class in medium temperature <sup>(2)</sup>		A+	A+	A+	A+	A++	A+	A+
SCOP medium temperature <sup>(2)</sup>	kWh/kWh	3,18	3,15	2,99	2,98	3,21	3,16	3,01
η <sub>s,h</sub> medium temperature <sup>(2)</sup>	%	124	123	117	116	126	123	117
Sound power <sup>(3)</sup>	dB (A)	78	78	78	79	80	80	83
Sound pressure <sup>(4)</sup>	dB (A)	46	46	46	47	48	48	51
HE/LS/HH - P2S/P2U		242	292	432	492	602	752	852
Heating capacity (EN14511) <sup>(1)</sup>	kW	24,0	29,5	41,8	50,3	58,3	66,9	81,3
Total input power (EN14511) <sup>(1)</sup>	kW	5,2	6,7	9,5	12,2	12,8	15,3	18,9
COP (EN14511) <sup>(1)</sup>	W/W	4,61	4,38	4,40	4,12	4,56	4,37	4,31
Energy Class in low temperature <sup>(2)</sup>		A++	A++	A++	A++	A++	A++	A++
SCOP low temperature <sup>(2)</sup>	kWh/kWh	4,10	3,96	3,87	3,83	4,08	4,06	3,83
η <sub>s,h</sub> low temperature <sup>(2)</sup>	%	161	156	152	150	160	159	150
Energy Class in medium temperature <sup>(2)</sup>		A++	A++	A+	A+	A++	A++	A+
SCOP medium temperature <sup>(2)</sup>	kWh/kWh	3,25	3,21	3,12	3,15	3,29	3,23	3,07
η <sub>s,h</sub> medium temperature <sup>(2)</sup>	%	127	125	122	123	129	126	120
Sound power <sup>(3)</sup>	dB (A)	78	78	78	79	80	80	83
Sound pressure <sup>(4)</sup>	dB (A)	46	46	46	47	48	48	51
Power supply	V/Ph/Hz	400/3+N/50	400/3+N/50	400/3/50	400/3/50	400/3/50	400/3/50	400/3/50
Compressors / Circuits	n° / n°	2 / 1	2 / 1	2 / 1	2 / 1	2 / 1	2 / 1	2 / 1
Fans	n°	1	1	2	2	2	2	2
Refrigerant		R410A	R410A	R410A	R410A	R410A	R410A	R410A
Refrigerant charge	kg	10,0	10,0	14,5	12,0	18,0	23,0	23,0
Global warming potential (GWP)		2088	2088	2088	2088	2088	2088	2088
Equivalent CO <sub>2</sub> charge	t	20,88	20,88	30,27	25,05	37,58	48,02	48,02
Water tank volume	l	100	100	100	100	300	300	300

HA/LS/HH - P2S/P2U		1002	1202	1454	1654	1854	2154
Heating capacity (EN14511) <sup>(1)</sup>	kW	88,4	102,5	145,6	163,7	181,9	210,2
Total input power (EN14511) <sup>(1)</sup>	kW	21,4	25,3	35,2	40,7	43,8	52,2
COP (EN14511) <sup>(1)</sup>	W/W	4,13	4,05	4,14	4,02	4,16	4,02
Energy Class in low temperature <sup>(2)</sup>		A+	A+	A+	A+	A+	A+
SCOP low temperature <sup>(2)</sup>	kWh/kWh	3,80	3,78	3,74	3,65	3,79	3,78
η <sub>s,h</sub> low temperature <sup>(2)</sup>	%	149	148	147	143	149	148
Energy Class in medium temperature <sup>(2)</sup>		A+	A+	A+	A+	A+	A+
SCOP medium temperature <sup>(2)</sup>	kWh/kWh	3,05	3,06	3,05	3,03	3,12	3,16
η <sub>s,h</sub> medium temperature <sup>(2)</sup>	%	119	120	119	118	122	123
Sound power <sup>(3)</sup>	dB (A)	83	83	84	85	85	85
Sound pressure <sup>(4)</sup>	dB (A)	51	51	52	53	53	53
HE/LS/HH - P2S/P2U		1002	1202	1454	1654	1854	2154
Heating capacity (EN14511) <sup>(1)</sup>	kW	88,5	102,7	145,2	163,2	181,3	209,6
Total input power (EN14511) <sup>(1)</sup>	kW	20,6	24,6	33,4	38,9	41,9	50,5
COP (EN14511) <sup>(1)</sup>	W/W	4,31	4,17	4,35	4,19	4,33	4,15
Energy Class in low temperature <sup>(2)</sup>		A++	A++	A++	A++	A++	A++
SCOP low temperature <sup>(2)</sup>	kWh/kWh	3,85	3,84	3,88	3,88	3,89	3,89
η <sub>s,h</sub> low temperature <sup>(2)</sup>	%	151	151	152	152	153	153
Energy Class in medium temperature <sup>(2)</sup>		A+	A+	A+	A+	A+	A+
SCOP medium temperature <sup>(2)</sup>	kWh/kWh	3,14	3,13	3,10	3,15	3,17	3,19
η <sub>s,h</sub> medium temperature <sup>(2)</sup>	%	123	122	121	123	124	124
Sound power <sup>(3)</sup>	dB (A)	83	83	84	85	85	85
Sound pressure <sup>(4)</sup>	dB (A)	51	51	52	53	53	53
Power supply	V/Ph/Hz	400/3/50	400/3/50	400/3/50	400/3/50	400/3/50	400/3/50
Compressors / Circuits	n° / n°	2 / 1	2 / 1	4/2	4/2	4/2	4/2
Fans	n°	2	2	3	3	3	3
Refrigerant		R410A	R410A	R410A	R410A	R410A	R410A
Refrigerant charge	kg	27,0	27,0	45,0	45,0	50,0	50,0
Global warming potential (GWP)		2088	2088	2088	2088	2088	2088
Equivalent CO <sub>2</sub> charge	t	56,37	56,37	93,96	93,96	104,40	104,40
Water tank volume	l	300	300	500	500	500	500

Performances are referred to the following conditions:

(1) Heating: Ambient temperature 7°C DB, 6°C WB, water temperature 30/35°C.

(2) Average conditions, variable - Reg EU 811/2013

(3) Sound power level in accordance with ISO 3744.

(4) Sound pressure level at 10 mt from the unit in free field conditions in accordance with ISO 3744.

Heating only version (HH)

HA/XL/HH - P2S/P2U		252	302	432	492	602	752	852
Heating capacity (EN14511) <sup>(1)</sup>	kW	24,0	29,6	41,1	48,9	57,4	65,5	80,1
Total input power (EN14511) <sup>(1)</sup>	kW	5,5	7,0	9,5	12,1	12,9	15,2	18,4
COP (EN14511) <sup>(1)</sup>	W/W	4,40	4,24	4,35	4,04	4,46	4,31	4,35
Energy Class in low temperature <sup>(2)</sup>		A++	A++	A++	A++	A++	A++	A++
SCOP low temperature <sup>(2)</sup>	kWh/kWh	3,83	3,84	3,84	3,83	4,03	4,01	3,83
η <sub>s,h</sub> low temperature <sup>(2)</sup>	%	150	151	151	150	158	158	150
Energy Class in medium temperature <sup>(2)</sup>		A+	A+	A+	A+	A++	A+	A+
SCOP medium temperature <sup>(2)</sup>	kWh/kWh	3,05	3,13	3,11	3,14	3,27	3,20	3,13
η <sub>s,h</sub> medium temperature <sup>(2)</sup>	%	119	122	121	122	128	125	122
Sound power <sup>(3)</sup>	dB (A)	72	72	73	74	74	74	74
Sound pressure <sup>(4)</sup>	dB (A)	40	40	41	42	42	42	42
HE/XL/HH - P2S/P2U		252	302	432	492	602	752	852
Heating capacity (EN14511) <sup>(1)</sup>	kW	24,0	30,0	41,2	49,2	57,4	65,6	79,9
Total input power (EN14511) <sup>(1)</sup>	kW	5,2	6,8	9,2	11,8	12,6	15,1	17,8
COP (EN14511) <sup>(1)</sup>	W/W	4,64	4,39	4,49	4,16	4,57	4,35	4,49
Energy Class in low temperature <sup>(2)</sup>		A++	A++	A++	A++	A++	A++	A++
SCOP low temperature <sup>(2)</sup>	kWh/kWh	4,10	3,87	4,00	3,84	4,21	4,16	4,04
η <sub>s,h</sub> low temperature <sup>(2)</sup>	%	161	152	157	151	165	163	159
Energy Class in medium temperature <sup>(2)</sup>		A++	A+	A++	A++	A++	A++	A++
SCOP medium temperature <sup>(2)</sup>	kWh/kWh	3,24	3,14	3,24	3,16	3,38	3,29	3,26
η <sub>s,h</sub> medium temperature <sup>(2)</sup>	%	127	123	127	123	132	129	127
Sound power <sup>(3)</sup>	dB (A)	71	72	73	74	73	73	74
Sound pressure <sup>(4)</sup>	dB (A)	39	40	41	42	41	41	42
Power supply	V/Ph/Hz	400/3+N/50	400/3+N/50	400/3/50	400/3/50	400/3/50	400/3/50	400/3/50
Compressors / Circuits	n° / n°	2 / 1	2 / 1	2 / 1	2 / 1	2 / 1	2 / 1	2 / 1
Fans	n°	2	2	2	2	2	2	2
Refrigerant		R410A	R410A	R410A	R410A	R410A	R410A	R410A
Refrigerant charge	kg	10,0	10,0	14,5	12,0	18,0	23,0	23,0
Global warming potential (GWP)		2088	2088	2088	2088	2088	2088	2088
Equivalent CO <sub>2</sub> charge	t	20,88	20,88	30,27	25,05	37,58	48,02	48,02
Water tank volume	l	100	100	100	100	300	300	300

HA/XL/HH - P2S/P2U		1002	1202	1454	1654	1854	2154
Heating capacity (EN14511) <sup>(1)</sup>	kW	87,3	100,7	147,8	166,9	187,4	218,2
Total input power (EN14511) <sup>(1)</sup>	kW	20,0	23,8	33,5	38,7	43,1	51,3
COP (EN14511) <sup>(1)</sup>	W/W	4,37	4,23	4,41	4,31	4,35	4,25
Energy Class in low temperature <sup>(2)</sup>		A++	A++	A++	A++	A++	A++
SCOP low temperature <sup>(2)</sup>	kWh/kWh	3,91	3,84	3,93	3,90	3,88	3,88
η <sub>s,h</sub> low temperature <sup>(2)</sup>	%	153	151	154	153	152	152
Energy Class in medium temperature <sup>(2)</sup>		A++	A+	A+	A+	A+	A+
SCOP medium temperature <sup>(2)</sup>	kWh/kWh	3,21	3,18	3,16	3,17	3,10	3,13
η <sub>s,h</sub> medium temperature <sup>(2)</sup>	%	126	124	123	124	121	122
Sound power <sup>(3)</sup>	dB (A)	75	75	79	79	80	80
Sound pressure <sup>(4)</sup>	dB (A)	43	43	47	47	48	48
HE/XL/HH - P2S/P2U		1002	1202	1454	1654	1854	2154
Heating capacity (EN14511) <sup>(1)</sup>	kW	87,2	100,7	147,6	166,6	187,6	218,2
Total input power (EN14511) <sup>(1)</sup>	kW	19,4	23,5	32,3	37,6	41,2	49,5
COP (EN14511) <sup>(1)</sup>	W/W	4,49	4,29	4,57	4,43	4,55	4,41
Energy Class in low temperature <sup>(2)</sup>		A++	A++	A++	A++	A++	A++
SCOP low temperature <sup>(2)</sup>	kWh/kWh	4,06	3,93	4,10	4,00	3,94	3,92
η <sub>s,h</sub> low temperature <sup>(2)</sup>	%	160	154	161	157	154	154
Energy Class in medium temperature <sup>(2)</sup>		A++	A++	A++	A++	A++	A++
SCOP medium temperature <sup>(2)</sup>	kWh/kWh	3,33	3,25	3,28	3,29	3,28	3,28
η <sub>s,h</sub> medium temperature <sup>(2)</sup>	%	130	127	128	129	128	128
Sound power <sup>(3)</sup>	dB (A)	75	75	79	79	80	80
Sound pressure <sup>(4)</sup>	dB (A)	43	43	47	47	48	48
Power supply	V/Ph/Hz	400/3/50	400/3/50	400/3/50	400/3/50	400/3/50	400/3/50
Compressors / Circuits	n° / n°	2 / 1	2 / 1	4/2	4/2	4/2	4/2
Fans	n°	2	2	4	4	6	6
Refrigerant		R410A	R410A	R410A	R410A	R410A	R410A
Refrigerant charge	kg	27,0	27,0	50,0	50,0	55,0	55,0
Global warming potential (GWP)		2088	2088	2088	2088	2088	2088
Equivalent CO <sub>2</sub> charge	t	56,37	56,37	104,40	104,40	114,84	114,84
Water tank volume	l	300	300	500	500	500	500

Performances are referred to the following conditions:

(1) Heating: Ambient temperature 7°C DB, 6°C WB, water temperature 30/35°C.

(2) Average conditions, variable - Reg EU 811/2013

(3) Sound power level in accordance with ISO 3744.

(4) Sound pressure level at 10 mt from the unit in free field conditions in accordance with ISO 3744.

## Heating only version (HH)

HE/NN/HH - P2S/P2U		252	312	452	502	602	752	852
Heating capacity (EN14511) <sup>(1)</sup>	kW	23,4	30,5	41,1	54,2	60,7	70,4	79,5
Total input power (EN14511) <sup>(1)</sup>	kW	5,0	6,4	8,8	11,7	12,4	14,7	17,41
COP (EN14511) <sup>(1)</sup>	W/W	4,69	4,75	4,69	4,64	4,89	4,78	4,56
Energy Class in low temperature <sup>(2)</sup>		A++	A++	A++	A++	A++	A++	A++
SCOP low temperature <sup>(2)</sup>	kWh/kWh	4,30	4,35	4,23	4,10	4,37	4,40	4,22
$\eta_{s,h}$ low temperature <sup>(2)</sup>	%	169	171	166	161	172	173	166
Energy Class in medium temperature <sup>(2)</sup>		A++	A++	A++	A++	A++	A++	A++
SCOP medium temperature <sup>(2)</sup>	kWh/kWh	3,34	3,48	3,42	3,34	3,47	3,45	3,38
$\eta_{s,h}$ medium temperature <sup>(2)</sup>	%	131	136	134	131	136	135	132
Sound power <sup>(3)</sup>	dB (A)	68	69	71	71	71	72	72
Sound pressure <sup>(4)</sup>	dB (A)	36	37	39	39	39	40	40
Power supply	V/Ph/Hz	400/3+N/50	400/3/50	400/3/50	400/3/50	400/3/50	400/3/50	400/3/50
Compressors / Circuits	n° / n°	2 / 1	2 / 1	2 / 1	2 / 1	2 / 1	2 / 1	2 / 1
Fans	n°	2	2	2	2	2	2	2
Refrigerant		R410A	R410A	R410A	R410A	R410A	R410A	R410A
Refrigerant charge	kg	10,0	10,0	18,0	23,0	18,0	23,0	23,0
Global warming potential (GWP)		2088,0	2088	2088	2088	2088	2088	2088
Equivalent CO <sub>2</sub> charge	t	20,88	20,88	37,58	48,02	37,58	48,02	48,02

HE/NN/HH - P2S/P2U		1002	1202	1454	1654	1854	2154
Heating capacity (EN14511) <sup>(1)</sup>	kW	90,3	104,9	146,7	165,1	184,7	214,0
Total input power (EN14511) <sup>(1)</sup>	kW	18,6	22,1	31,5	36,6	40,0	48,0
COP (EN14511) <sup>(1)</sup>	W/W	4,87	4,75	4,66	4,51	4,62	4,46
Energy Class in low temperature <sup>(2)</sup>		A++	A++	A++	A++	A++	A++
SCOP low temperature <sup>(2)</sup>	kWh/kWh	4,42	4,31	4,31	4,15	4,23	4,12
$\eta_{s,h}$ low temperature <sup>(2)</sup>	%	174	169	169	163	166	162
Energy Class in medium temperature <sup>(2)</sup>		A++	A++	A++	A++	A++	A++
SCOP medium temperature <sup>(2)</sup>	kWh/kWh	3,52	3,50	3,41	3,40	3,47	3,42
$\eta_{s,h}$ medium temperature <sup>(2)</sup>	%	138	137	134	133	136	134
Sound power <sup>(3)</sup>	dB (A)	72	72	74	74	75	75
Sound pressure <sup>(4)</sup>	dB (A)	40	40	42	42	43	43
Power supply	V/Ph/Hz	400/3/50	400/3/50	400/3/50	400/3/50	400/3/50	400/3/50
Compressors / Circuits	n° / n°	2 / 1	2 / 1	4/2	4/2	4/2	4/2
Fans	n°	3	3	4	4	6	6
Refrigerant		R410A	R410A	R410A	R410A	R410A	R410A
Refrigerant charge	kg	36,0	36,0	50,0	50,0	55,0	55,0
Global warming potential (GWP)		2088	2088	2088	2088	2088	2088
Equivalent CO <sub>2</sub> charge	t	75,16	75,16	104,40	104,40	114,84	114,84

Performances are referred to the following conditions:

(1) Heating: Ambient temperature 7°C DB, 6°C WB, water temperature 30/35°C.

(2) Average conditions, variable - Reg EU 811/2013

(3) Sound power level in accordance with ISO 3744.

(4) Sound pressure level at 10 mt from the unit in free field conditions in accordance with ISO 3744.

Reversible heating/cooling version (RV)

SA/LS/RV - P2S/P2U		242	292	432	492	592	752	852
Heating capacity (EN14511) <sup>(1)</sup>	kW	23,7	28,3	42,1	50,9	55,0	67,8	74,5
Total input power (EN14511) <sup>(1)</sup>	kW	5,5	6,8	10,3	12,3	13,4	16,3	18,3
COP (EN14511) <sup>(1)</sup>	W/W	4,31	4,16	4,11	4,14	4,12	4,16	4,07
Energy Class in low temperature <sup>(2)</sup>		A+	A+	A+	A+	A+	A+	A+
SCOP low temperature <sup>(2)</sup>	kWh/kWh	3,75	3,77	3,39	3,33	3,49	3,70	3,62
η <sub>s,h</sub> low temperature <sup>(2)</sup>	%	147	148	133	130	137	145	142
Energy Class in medium temperature <sup>(2)</sup>		A+	A+	A+	A+	A+	A+	A+
SCOP medium temperature <sup>(2)</sup>	kWh/kWh	3,04	3,07	2,89	2,87	2,93	3,06	3,03
η <sub>s,h</sub> medium temperature <sup>(2)</sup>	%	119	120	112	112	114	119	118
Cooling capacity (EN14511) <sup>(3)</sup>	kW	22,5	29,5	36,4	46,1	53,6	61,6	74,3
Total input power (EN14511) <sup>(3)</sup>	kW	7,1	9,1	12,9	16,4	19,3	22,3	25,5
EER (EN14511) <sup>(3)</sup>	W/W	3,15	3,24	2,82	2,80	2,78	2,76	2,91
Sound power <sup>(4)</sup>	dB (A)	78	78	79	80	80	80	80
Sound pressure <sup>(5)</sup>	dB (A)	46	46	47	48	48	48	48
SE/LS/RV - P2S/P2U		242	292	432	492	592	752	852
Heating capacity (EN14511) <sup>(1)</sup>	kW	23,7	28,3	42,1	50,5	55,2	67,8	74,7
Total input power (EN14511) <sup>(1)</sup>	kW	5,3	6,7	9,9	12,8	13,8	16,1	18,2
COP (EN14511) <sup>(1)</sup>	W/W	4,47	4,22	4,25	3,95	4,00	4,21	4,10
Energy Class in low temperature <sup>(2)</sup>		A++	A++	A+	A+	A+	A+	A+
SCOP low temperature <sup>(2)</sup>	kWh/kWh	3,95	3,87	3,58	3,45	3,59	3,79	3,68
η <sub>s,h</sub> low temperature <sup>(2)</sup>	%	155	152	140	135	141	149	144
Energy Class in medium temperature <sup>(2)</sup>		A+	A+	A+	A+	A+	A+	A+
SCOP medium temperature <sup>(2)</sup>	kWh/kWh	3,17	3,13	3,02	2,99	3,02	3,13	3,10
η <sub>s,h</sub> medium temperature <sup>(2)</sup>	%	124	122	118	116	118	122	121
Cooling capacity (EN14511) <sup>(3)</sup>	kW	22,65	29,92	36,5	46,43	53,75	61,94	74,64
Total input power (EN14511) <sup>(3)</sup>	kW	7,1	9,0	12,8	16,2	19,2	21,9	25,4
EER (EN14511) <sup>(3)</sup>	W/W	3,19	3,32	2,86	2,86	2,81	2,83	2,94
Sound power <sup>(4)</sup>	dB (A)	78	78	79	80	80	80	80
Sound pressure <sup>(5)</sup>	dB (A)	46	46	47	48	48	48	48
Power supply	V/Ph/Hz	400/3+N/50	400/3+N/50	400/3/50	400/3/50	400/3/50	400/3/50	400/3/50
Compressors / Circuits	n° / n°	2 / 1	2 / 1	2 / 1	2 / 1	2 / 1	2 / 1	2 / 1
Fans	n°	1	1	2	2	2	2	2
Refrigerant		R410A	R410A	R410A	R410A	R410A	R410A	R410A
Refrigerant charge	kg	10,0	10,0	10,0	12,0	12,0	18,0	19,0
Global warming potential (GWP)		2088	2088	2088	2088	2088	2088	2088
Equivalent CO <sub>2</sub> charge	t	20,88	20,88	20,88	25,05	25,05	37,58	39,67
Water tank volume	l	100	100	100	100	100	300	300

SA/LS/RV - P2S/P2U		1002	1202	1454	1654	1854	2154
Heating capacity (EN14511) <sup>(1)</sup>	kW	88,5	102,5	145,3	162,9	180,2	205,4
Total input power (EN14511) <sup>(1)</sup>	kW	21,1	25,8	35,2	41,2	43,6	52,9
COP (EN14511) <sup>(1)</sup>	W/W	4,21	3,98	4,13	3,96	4,13	3,88
Energy Class in low temperature <sup>(2)</sup>		A+	A+	A+	A+	A+	A+
SCOP low temperature <sup>(2)</sup>	kWh/kWh	3,61	3,60	3,44	3,42	3,43	3,42
η <sub>s,h</sub> low temperature <sup>(2)</sup>	%	141	141	135	134	134	134
Energy Class in medium temperature <sup>(2)</sup>		A+	A+	A+	A+	A+	A+
SCOP medium temperature <sup>(2)</sup>	kWh/kWh	3,01	2,99	2,85	2,90	2,92	2,95
η <sub>s,h</sub> medium temperature <sup>(2)</sup>	%	117	117	111	113	114	115
Cooling capacity (EN14511) <sup>(3)</sup>	kW	77,9	90,4	125,8	142,0	155,1	177,9
Total input power (EN14511) <sup>(3)</sup>	kW	26,9	32,6	44,1	51,7	55,3	68,6
EER (EN14511) <sup>(3)</sup>	W/W	2,89	2,77	2,85	2,75	2,80	2,59
Sound power <sup>(4)</sup>	dB (A)	80	80	87	87	88	89
Sound pressure <sup>(5)</sup>	dB (A)	48	48	55	55	56	57
SE/LS/RV - P2S/P2U		1002	1202	1454	1654	1854	2154
Heating capacity (EN14511) <sup>(1)</sup>	kW	88,2	102,5	146,0	164,3	181,3	208,1
Total input power (EN14511) <sup>(1)</sup>	kW	20,7	25,4	33,6	39,03	41,91	50,66
COP (EN14511) <sup>(1)</sup>	W/W	4,26	4,03	4,35	4,21	4,33	4,11
Energy Class in low temperature <sup>(2)</sup>		A+	A+	A+	A+	A+	A+
SCOP low temperature <sup>(2)</sup>	kWh/kWh	3,69	3,70	3,63	3,57	3,69	3,63
η <sub>s,h</sub> low temperature <sup>(2)</sup>	%	145	145	142	140	145	142
Energy Class in medium temperature <sup>(2)</sup>		A+	A+	A+	A+	A+	A+
SCOP medium temperature <sup>(2)</sup>	kWh/kWh	3,10	3,06	2,95	2,99	3,06	3,07
η <sub>s,h</sub> medium temperature <sup>(2)</sup>	%	121	120	115	117	120	120
Cooling capacity (EN14511) <sup>(3)</sup>	kW	78,1	90,9	126,4	143,1	156,3	179,3
Total input power (EN14511) <sup>(3)</sup>	kW	25,0	32,1	41,7	49,5	53,5	66,1
EER (EN14511) <sup>(3)</sup>	W/W	3,13	2,83	3,03	2,89	2,92	2,71
Sound power <sup>(4)</sup>	dB (A)	80	80	86	87	88	89
Sound pressure <sup>(5)</sup>	dB (A)	48	48	54	55	56	57
Power supply	V/Ph/Hz	400/3/50	400/3/50	400/3/50	400/3/50	400/3/50	400/3/50
Compressors / Circuits	n° / n°	2 / 1	2 / 1	4/2	4/2	4/2	4/2
Fans	n°	3	4	4	4	4	4
Refrigerant		R410A	R410A	R410A	R410A	R410A	R410A
Refrigerant charge	kg	23,0	23,0	45,0	45,0	50,0	50,0
Global warming potential (GWP)		2088	2088	2088	2088	2088	2088
Equivalent CO <sub>2</sub> charge	t	48,02	48,02	93,96	93,96	104,40	104,40
Water tank volume	l	300	300	500	500	500	500

Performances are referred to the following conditions:

(1) Heating: Ambient temperature 7°C DB, 6°C WB, water temperature 30/35°C.

(2) Average conditions, variable - Reg EU 811/2013

(3) Cooling: ambient air temperature 35°C, evaporator water temperature in/out 12/7 °C.

(4) Sound power level in accordance with ISO 3744.

(5) Sound pressure level at 10 mt from the unit in free field conditions in accordance with ISO 3744.

Reversible heating/cooling version (RV)

L7

HA/LS/RV - P2S/P2U		242	292	432	492	602	752	852
Heating capacity (EN14511) <sup>(1)</sup>	kW	23,8	29,4	41,6	51,2	58,0	66,7	80,8
Total input power (EN14511) <sup>(1)</sup>	kW	5,3	6,8	9,7	12,4	13,0	15,6	19,6
COP (EN14511) <sup>(1)</sup>	W/W	4,51	4,31	4,29	4,12	4,45	4,29	4,13
Energy Class in low temperature <sup>(2)</sup>		A++	A++	A+	A+	A++	A++	A+
SCOP low temperature <sup>(2)</sup>	kWh/kWh	3,96	3,89	3,63	3,55	3,94	3,95	3,76
η <sub>s,h</sub> low temperature <sup>(2)</sup>	%	155	153	142	139	155	155	147
Energy Class in medium temperature <sup>(2)</sup>		A+	A+	A+	A+	A++	A+	A+
SCOP medium temperature <sup>(2)</sup>	kWh/kWh	3,18	3,15	2,99	2,98	3,21	3,16	3,01
η <sub>s,h</sub> medium temperature <sup>(2)</sup>	%	124	123	117	116	126	123	117
Cooling capacity (EN14511) <sup>(3)</sup>	kW	22,9	30,1	37,5	46,7	52,8	62,5	71,6
Total input power (EN14511) <sup>(3)</sup>	kW	7,0	9,0	12,7	16,1	18,1	21,6	24,6
EER (EN14511) <sup>(3)</sup>	W/W	3,25	3,36	2,97	2,90	2,91	2,89	2,91
Sound power <sup>(4)</sup>	dB (A)	78	78	78	79	80	80	83
Sound pressure <sup>(5)</sup>	dB (A)	46	46	46	47	48	48	51
HE/LS/RV - P2S/P2U		242	292	432	492	602	752	852
Heating capacity (EN14511) <sup>(1)</sup>	kW	24,0	29,5	41,8	50,3	58,3	66,9	81,3
Total input power (EN14511) <sup>(1)</sup>	kW	5,2	6,7	9,5	12,2	12,8	15,3	18,9
COP (EN14511) <sup>(1)</sup>	W/W	4,61	4,38	4,40	4,12	4,56	4,37	4,31
Energy Class in low temperature <sup>(2)</sup>		A++	A++	A++	A++	A++	A++	A++
SCOP low temperature <sup>(2)</sup>	kWh/kWh	4,10	3,96	3,87	3,83	4,08	4,06	3,83
η <sub>s,h</sub> low temperature <sup>(2)</sup>	%	161	156	152	150	160	159	150
Energy Class in medium temperature <sup>(2)</sup>		A++	A++	A+	A+	A++	A++	A+
SCOP medium temperature <sup>(2)</sup>	kWh/kWh	3,25	3,21	3,12	3,15	3,29	3,23	3,07
η <sub>s,h</sub> medium temperature <sup>(2)</sup>	%	127	125	122	123	129	126	120
Cooling capacity (EN14511) <sup>(3)</sup>	kW	22,9	30,2	37,5	45,6	52,9	62,5	71,6
Total input power (EN14511) <sup>(3)</sup>	kW	7,0	8,8	12,7	16,7	17,9	21,3	24,4
EER (EN14511) <sup>(3)</sup>	W/W	3,27	3,42	2,96	2,73	2,95	2,64	2,94
Sound power <sup>(4)</sup>	dB (A)	78	78	78	79	80	80	83
Sound pressure <sup>(5)</sup>	dB (A)	46	46	46	47	48	48	51
Power supply	V/Ph/Hz	400/3+N/50	400/3+N/50	400/3/50	400/3/50	400/3/50	400/3/50	400/3/50
Compressors / Circuits	n° / n°	2 / 1	2 / 1	2 / 1	2 / 1	2 / 1	2 / 1	2 / 1
Fans	n°	1	1	2	2	2	2	2
Refrigerant		R410A	R410A	R410A	R410A	R410A	R410A	R410A
Refrigerant charge	kg	10,0	10,0	14,5	12,0	18,0	23,0	23,0
Global warming potential (GWP)		2088	2088	2088	2088	2088	2088	2088
Equivalent CO <sub>2</sub> charge	t	20,88	20,88	30,27	25,05	37,58	48,02	48,02
Water tank volume	l	100	100	100	100	300	300	300
HA/LS/RV - P2S/P2U		1002	1202	1454	1654	1854	2154	
Heating capacity (EN14511) <sup>(1)</sup>	kW	88,4	102,5	145,6	163,7	181,9	210,2	
Total input power (EN14511) <sup>(1)</sup>	kW	21,4	25,3	35,2	40,7	43,8	52,2	
COP (EN14511) <sup>(1)</sup>	W/W	4,13	4,05	4,14	4,02	4,16	4,02	
Energy Class in low temperature <sup>(2)</sup>		A+	A+	A+	A+	A+	A+	
SCOP low temperature <sup>(2)</sup>	kWh/kWh	3,80	3,78	3,74	3,65	3,79	3,78	
η <sub>s,h</sub> low temperature <sup>(2)</sup>	%	149	148	147	143	149	148	
Energy Class in medium temperature <sup>(2)</sup>		A+	A+	A+	A+	A+	A+	
SCOP medium temperature <sup>(2)</sup>	kWh/kWh	3,05	3,06	3,05	3,03	3,12	3,16	
η <sub>s,h</sub> medium temperature <sup>(2)</sup>	%	119	120	119	118	122	123	
Cooling capacity (EN14511) <sup>(3)</sup>	kW	78,1	90,2	127,4	143,5	157,8	180,9	
Total input power (EN14511) <sup>(3)</sup>	kW	26,6	32,2	42,4	50,8	53,6	66,5	
EER (EN14511) <sup>(3)</sup>	W/W	2,94	2,80	3,01	2,82	2,94	2,72	
Sound power <sup>(4)</sup>	dB (A)	83	83	84	85	85	85	
Sound pressure <sup>(5)</sup>	dB (A)	51	51	52	53	53	53	
HE/LS/RV - P2S/P2U		1002	1202	1454	1654	1854	2154	
Heating capacity (EN14511) <sup>(1)</sup>	kW	88,5	102,7	145,2	163,2	181,3	209,6	
Total input power (EN14511) <sup>(1)</sup>	kW	20,6	24,6	33,4	38,9	41,9	50,5	
COP (EN14511) <sup>(1)</sup>	W/W	4,31	4,17	4,35	4,19	4,33	4,15	
Energy Class in low temperature <sup>(2)</sup>		A++	A++	A++	A++	A++	A++	
SCOP low temperature <sup>(2)</sup>	kWh/kWh	3,85	3,84	3,88	3,88	3,89	3,89	
η <sub>s,h</sub> low temperature <sup>(2)</sup>	%	151	151	152	152	153	153	
Energy Class in medium temperature <sup>(2)</sup>		A+	A+	A+	A+	A+	A+	
SCOP medium temperature <sup>(2)</sup>	kWh/kWh	3,14	3,13	3,10	3,15	3,17	3,19	
η <sub>s,h</sub> medium temperature <sup>(2)</sup>	%	123	122	121	123	124	124	
Cooling capacity (EN14511) <sup>(3)</sup>	kW	78,2	90,8	126,8	142,8	157,0	180,1	
Total input power (EN14511) <sup>(3)</sup>	kW	26,1	31,3	42,0	50,5	53,4	66,2	
EER (EN14511) <sup>(3)</sup>	W/W	3,00	2,90	3,02	2,83	2,94	2,72	
Sound power <sup>(4)</sup>	dB (A)	83	83	84	85	85	85	
Sound pressure <sup>(5)</sup>	dB (A)	51	51	52	53	53	53	
Power supply	V/Ph/Hz	400/3/50	400/3/50	400/3/50	400/3/50	400/3/50	400/3/50	
Compressors / Circuits	n° / n°	2 / 1	2 / 1	4/2	4/2	4/2	4/2	
Fans	n°	2	2	3	3	3	3	
Refrigerant		R410A	R410A	R410A	R410A	R410A	R410A	
Refrigerant charge	kg	27,0	27,0	45,0	45,0	50,0	50,0	
Global warming potential (GWP)		2088	2088	2088	2088	2088	2088	
Equivalent CO <sub>2</sub> charge	t	56,37	56,37	93,96	93,96	104,40	104,40	
Water tank volume	l	300	300	500	500	500	500	

Performances are referred to the following conditions:

- (1) Heating: Ambient temperature 7°C DB, 6°C WB, water temperature 30/35°C.
- (2) Average conditions, variable - Reg EU 811/2013

- (3) Cooling: ambient air temperature 35°C, evaporator water temperature in/out 12/7 °C.

- (4) Sound power level in accordance with ISO 3744.

- (5) Sound pressure level at 10 mt from the unit in free field conditions in accordance with ISO 3744.



Reversible heating/cooling version (RV)

HA/XL/RV - P2S/P2U		252	302	432	492	602	752	852
Heating capacity (EN14511) <sup>(1)</sup>	kW	24,0	29,6	41,1	48,9	57,4	65,5	80,1
Total input power (EN14511) <sup>(1)</sup>	kW	5,5	7,0	9,5	12,1	12,9	15,2	18,4
COP (EN14511) <sup>(1)</sup>	W/W	4,40	4,24	4,35	4,04	4,46	4,31	4,35
Energy Class in low temperature <sup>(2)</sup>		A++	A++	A++	A++	A++	A++	A++
SCOP low temperature <sup>(2)</sup>	kWh/kWh	3,83	3,84	3,84	3,83	4,03	4,01	3,83
η <sub>s,h</sub> low temperature <sup>(2)</sup>	%	150	151	151	150	158	158	150
Energy Class in medium temperature <sup>(2)</sup>		A+	A+	A+	A+	A++	A+	A+
SCOP medium temperature <sup>(2)</sup>	kWh/kWh	3,05	3,13	3,11	3,14	3,27	3,20	3,13
η <sub>s,h</sub> medium temperature <sup>(2)</sup>	%	119	122	121	122	128	125	122
Cooling capacity (EN14511) <sup>(3)</sup>	kW	22,0	28,3	36,8	45,5	52,1	62,0	71,2
Total input power (EN14511) <sup>(3)</sup>	kW	7,1	9,1	13,2	16,1	18,9	21,9	23,7
EER (EN14511) <sup>(3)</sup>	W/W	3,10	3,13	2,78	2,82	2,75	2,83	3,00
Sound power <sup>(4)</sup>	dB (A)	72	72	73	74	74	74	74
Sound pressure <sup>(5)</sup>	dB (A)	40	40	41	42	42	42	42
HE/XL/RV - P2S/P2U		252	302	432	492	602	752	852
Heating capacity (EN14511) <sup>(1)</sup>	kW	24,0	30,0	41,2	49,2	57,4	65,6	79,9
Total input power (EN14511) <sup>(1)</sup>	kW	5,2	6,8	9,2	11,8	12,6	15,1	17,8
COP (EN14511) <sup>(1)</sup>	W/W	4,64	4,39	4,49	4,16	4,57	4,35	4,49
Energy Class in low temperature <sup>(2)</sup>		A++	A++	A++	A++	A++	A++	A++
SCOP low temperature <sup>(2)</sup>	kWh/kWh	4,10	3,87	4,00	3,84	4,21	4,16	4,04
η <sub>s,h</sub> low temperature <sup>(2)</sup>	%	161	152	157	151	165	163	159
Energy Class in medium temperature <sup>(2)</sup>		A++	A+	A++	A++	A++	A++	A++
SCOP medium temperature <sup>(2)</sup>	kWh/kWh	3,24	3,14	3,24	3,16	3,38	3,29	3,26
η <sub>s,h</sub> medium temperature <sup>(2)</sup>	%	127	123	127	123	132	129	127
Cooling capacity (EN14511) <sup>(3)</sup>	kW	21,0	28,9	37,2	45,7	52,0	62,1	70,6
Total input power (EN14511) <sup>(3)</sup>	kW	7,0	9,1	12,7	16,0	18,8	21,8	24,2
EER (EN14511) <sup>(3)</sup>	W/W	2,98	3,17	2,93	2,85	2,78	2,85	2,92
Sound power <sup>(4)</sup>	dB (A)	71	72	73	74	73	73	74
Sound pressure <sup>(5)</sup>	dB (A)	39	40	41	42	41	41	42
Power supply	V/Ph/Hz	400/3+N/50	400/3+N/50	400/3/50	400/3/50	400/3/50	400/3/50	400/3/50
Compressors / Circuits	n° / n°	2 / 1	2 / 1	2 / 1	2 / 1	2 / 1	2 / 1	2 / 1
Fans	n°	2	2	2	2	2	2	2
Refrigerant		R410A	R410A	R410A	R410A	R410A	R410A	R410A
Refrigerant charge	kg	10,0	10,0	14,5	12,0	18,0	23,0	23,0
Global warming potential (GWP)		2088	2088	2088	2088	2088	2088	2088
Equivalent CO <sub>2</sub> charge	t	20,88	20,88	30,27	25,05	37,58	48,02	48,02
Water tank volume	l	100	100	100	100	300	300	300
HA/XL/RV - P2S/P2U		1002	1202	1454	1654	1854	2154	
Heating capacity (EN14511) <sup>(1)</sup>	kW	87,3	100,7	147,8	166,9	187,4	218,2	
Total input power (EN14511) <sup>(1)</sup>	kW	20,0	23,8	33,5	38,7	43,1	51,3	
COP (EN14511) <sup>(1)</sup>	W/W	4,37	4,23	4,41	4,31	4,35	4,25	
Energy Class in low temperature <sup>(2)</sup>		A++	A++	A++	A++	A++	A++	
SCOP low temperature <sup>(2)</sup>	kWh/kWh	3,91	3,84	3,93	3,90	3,88	3,88	
η <sub>s,h</sub> low temperature <sup>(2)</sup>	%	153	151	154	153	152	152	
Energy Class in medium temperature <sup>(2)</sup>		A++	A+	A+	A+	A+	A+	
SCOP medium temperature <sup>(2)</sup>	kWh/kWh	3,21	3,18	3,16	3,17	3,10	3,13	
η <sub>s,h</sub> medium temperature <sup>(2)</sup>	%	126	124	123	124	121	122	
Cooling capacity (EN14511) <sup>(3)</sup>	kW	77,1	88,7	126,6	143,4	158,7	184,3	
Total input power (EN14511) <sup>(3)</sup>	kW	26,2	32,6	40,9	48,1	49,7	61,3	
EER (EN14511) <sup>(3)</sup>	W/W	2,95	2,72	3,10	2,98	3,19	3,01	
Sound power <sup>(4)</sup>	dB (A)	75	75	79	79	80	80	
Sound pressure <sup>(5)</sup>	dB (A)	43	43	47	47	48	48	
HE/XL/RV - P2S/P2U		1002	1202	1454	1654	1854	2154	
Heating capacity (EN14511) <sup>(1)</sup>	kW	87,2	100,7	147,6	166,6	187,6	218,2	
Total input power (EN14511) <sup>(1)</sup>	kW	19,4	23,5	32,3	37,6	41,2	49,5	
COP (EN14511) <sup>(1)</sup>	W/W	4,49	4,29	4,57	4,43	4,55	4,41	
Energy Class in low temperature <sup>(2)</sup>		A++	A++	A++	A++	A++	A++	
SCOP low temperature <sup>(2)</sup>	kWh/kWh	4,06	3,93	4,10	4,00	3,94	3,92	
η <sub>s,h</sub> low temperature <sup>(2)</sup>	%	160	154	161	157	154	154	
Energy Class in medium temperature <sup>(2)</sup>		A++	A++	A++	A++	A++	A++	
SCOP medium temperature <sup>(2)</sup>	kWh/kWh	3,33	3,25	3,28	3,29	3,28	3,28	
η <sub>s,h</sub> medium temperature <sup>(2)</sup>	%	130	127	128	129	128	128	
Cooling capacity (EN14511) <sup>(3)</sup>	kW	76,9	88,1	126,5	142,7	158,7	184,3	
Total input power (EN14511) <sup>(3)</sup>	kW	26,3	32,9	40,3	48,4	49,7	60,3	
EER (EN14511) <sup>(3)</sup>	W/W	2,92	2,68	3,14	2,95	3,19	3,05	
Sound power <sup>(4)</sup>	dB (A)	75	75	79	79	80	80	
Sound pressure <sup>(5)</sup>	dB (A)	43	43	47	47	48	48	
Power supply	V/Ph/Hz	400/3/50	400/3/50	400/3/50	400/3/50	400/3/50	400/3/50	
Compressors / Circuits	n° / n°	2 / 1	2 / 1	4/2	4/2	4/2	4/2	
Fans	n°	2	2	4	4	6	6	
Refrigerant		R410A	R410A	R410A	R410A	R410A	R410A	
Refrigerant charge	kg	27,0	27,0	50,0	50,0	55,0	55,0	
Global warming potential (GWP)		2088	2088	2088	2088	2088	2088	
Equivalent CO <sub>2</sub> charge	t	56,37	56,37	104,40	104,40	114,84	114,84	
Water tank volume	l	300	300	500	500	500	500	

Performances are referred to the following conditions:

- (1) Heating: Ambient temperature 7°C DB, 6°C WB, water temperature 30/35°C.
- (2) Average conditions, variable - Reg EU 811/2013

- (3) Cooling: ambient air temperature 35°C, evaporator water temperature in/out 12/7 °C.

- (4) Sound power level in accordance with ISO 3744.

- (5) Sound pressure level at 10 mt from the unit in free field conditions in accordance with ISO 3744.

Reversible heating/cooling version (RV)

HE/NN/RV - P2S/P2U		252	312	452	502	602	752	852
Heating capacity (EN14511) <sup>(1)</sup>	kW	23,4	30,5	41,1	54,2	60,7	70,4	79,5
Total input power (EN14511) <sup>(1)</sup>	kW	5,0	6,4	8,8	11,7	12,4	14,7	17,41
COP (EN14511) <sup>(1)</sup>	W/W	4,69	4,75	4,69	4,64	4,89	4,78	4,56
Energy Class in low temperature <sup>(2)</sup>		A++	A++	A++	A++	A++	A++	A++
SCOP low temperature <sup>(2)</sup>	kWh/kWh	4,30	4,35	4,23	4,10	4,37	4,40	4,22
$\eta_{s,h}$ low temperature <sup>(2)</sup>	%	169	171	166	161	172	173	166
Energy Class in medium temperature <sup>(2)</sup>		A++	A++	A++	A++	A++	A++	A++
SCOP medium temperature <sup>(2)</sup>	kWh/kWh	3,34	3,48	3,42	3,34	3,47	3,45	3,38
$\eta_{s,h}$ medium temperature <sup>(2)</sup>	%	131	136	134	131	136	135	132
Cooling capacity (EN14511) <sup>(3)</sup>	kW	22,1	28,5	37,0	46,4	53,3	61,6	72,9
Total input power (EN14511) <sup>(3)</sup>	kW	6,9	9,1	12,6	14,9	16,8	20,9	25,1
EER (EN14511) <sup>(3)</sup>	W/W	3,20	3,15	2,93	3,11	3,18	2,95	2,90
Sound power <sup>(4)</sup>	dB (A)	68	69	71	71	71	72	72
Sound pressure <sup>(5)</sup>	dB (A)	36	37	39	39	39	40	40
Power supply	V/Ph/Hz	400/3+N/50	400/3/50	400/3/50	400/3/50	400/3/50	400/3/50	400/3/50
Compressors / Circuits	n° / n°	2 / 1	2 / 1	2 / 1	2 / 1	2 / 1	2 / 1	2 / 1
Fans	n°	2	2	2	2	2	2	2
Refrigerant		R410A	R410A	R410A	R410A	R410A	R410A	R410A
Refrigerant charge	kg	10,0	10,0	18,0	23,0	18,0	23,0	23,0
Global warming potential (GWP)		2088,0	2088	2088	2088	2088	2088	2088
Equivalent CO <sub>2</sub> charge	t	20,88	20,88	37,58	48,02	37,58	48,02	48,02

HE/NN/RV - P2S/P2U		1002	1202	1454	1654	1854	2154
Heating capacity (EN14511) <sup>(1)</sup>	kW	90,3	104,9	146,7	165,1	184,7	214,0
Total input power (EN14511) <sup>(1)</sup>	kW	18,6	22,1	31,5	36,6	40,0	48,0
COP (EN14511) <sup>(1)</sup>	W/W	4,87	4,75	4,66	4,51	4,62	4,46
Energy Class in low temperature <sup>(2)</sup>		A++	A++	A++	A++	A++	A++
SCOP low temperature <sup>(2)</sup>	kWh/kWh	4,42	4,31	4,31	4,15	4,23	4,12
$\eta_{s,h}$ low temperature <sup>(2)</sup>	%	174	169	169	163	166	162
Energy Class in medium temperature <sup>(2)</sup>		A++	A++	A++	A++	A++	A++
SCOP medium temperature <sup>(2)</sup>	kWh/kWh	3,52	3,50	3,41	3,40	3,47	3,42
$\eta_{s,h}$ medium temperature <sup>(2)</sup>	%	138	137	134	133	136	134
Cooling capacity (EN14511) <sup>(3)</sup>	kW	79,0	91,9	124,7	139,5	156,5	179,9
Total input power (EN14511) <sup>(3)</sup>	kW	24,7	29,8	41,5	50,9	50,8	63,3
EER (EN14511) <sup>(3)</sup>	W/W	3,20	3,08	3,01	2,74	3,08	2,84
Sound power <sup>(4)</sup>	dB (A)	72	72	74	74	75	75
Sound pressure <sup>(5)</sup>	dB (A)	40	40	42	42	43	43
Power supply	V/Ph/Hz	400/3/50	400/3/50	400/3/50	400/3/50	400/3/50	400/3/50
Compressors / Circuits	n° / n°	2 / 1	2 / 1	4/2	4/2	4/2	4/2
Fans	n°	3	3	4	4	6	6
Refrigerant		R410A	R410A	R410A	R410A	R410A	R410A
Refrigerant charge	kg	36,0	36,0	50,0	50,0	55,0	55,0
Global warming potential (GWP)		2088	2088	2088	2088	2088	2088
Equivalent CO <sub>2</sub> charge	t	75,16	75,16	104,40	104,40	114,84	114,84

Performances are referred to the following conditions:

- (1) Heating: Ambient temperature 7°C DB, 6°C WB, water temperature 30/35°C.  
 (2) Average conditions, variable - Reg EU 811/2013

- (3) Cooling: ambient air temperature 35°C, evaporator water temperature in/out 12/7 °C.

- (4) Sound power level in accordance with ISO 3744.

- (5) Sound pressure level at 10 mt from the unit in free field conditions in accordance with ISO 3744.

## What is the E.V.I. Technology (Enhanced Vapour Injection)?

Heat pumps utilise scroll compressors that are equipped with E.V.I. technology, a versatile method of improving system capacity and efficiency. EVI stands for "Economised Vapour Injection."

The technology involves injecting refrigerant vapour into the middle of the compression process, a procedure that significantly boosts capacity and efficiency. Each scroll compressor used in these units is similar to a two-stage compressor with built-in inter-stage cooling. The process begins when a portion of the condenser liquid is extracted and expanded through an expansion valve.

The low temperature liquid/gas mixture produced is injected into a heat exchanger that operates as a sub cooler. Any liquid is evaporated and the vapour produced is superheated.

The superheated vapour is then injected into an intermediate port in the scroll compressor. This cold vapour reduces the temperature of the compressed gas thus enabling the compressor to raise the pressure to levels (and temperatures) beyond that possible with a single stage scroll. The additional sub cooling of the main volume of liquid refrigerant increases the evaporator capacity. This compressor technology generates a larger pressure ratio between condensing and evaporating pressures, with significant performance improvement. Using this technology enables Hidros units to produce hot water up to 65°C and the ability to operate down to -20°C ambient temperature.

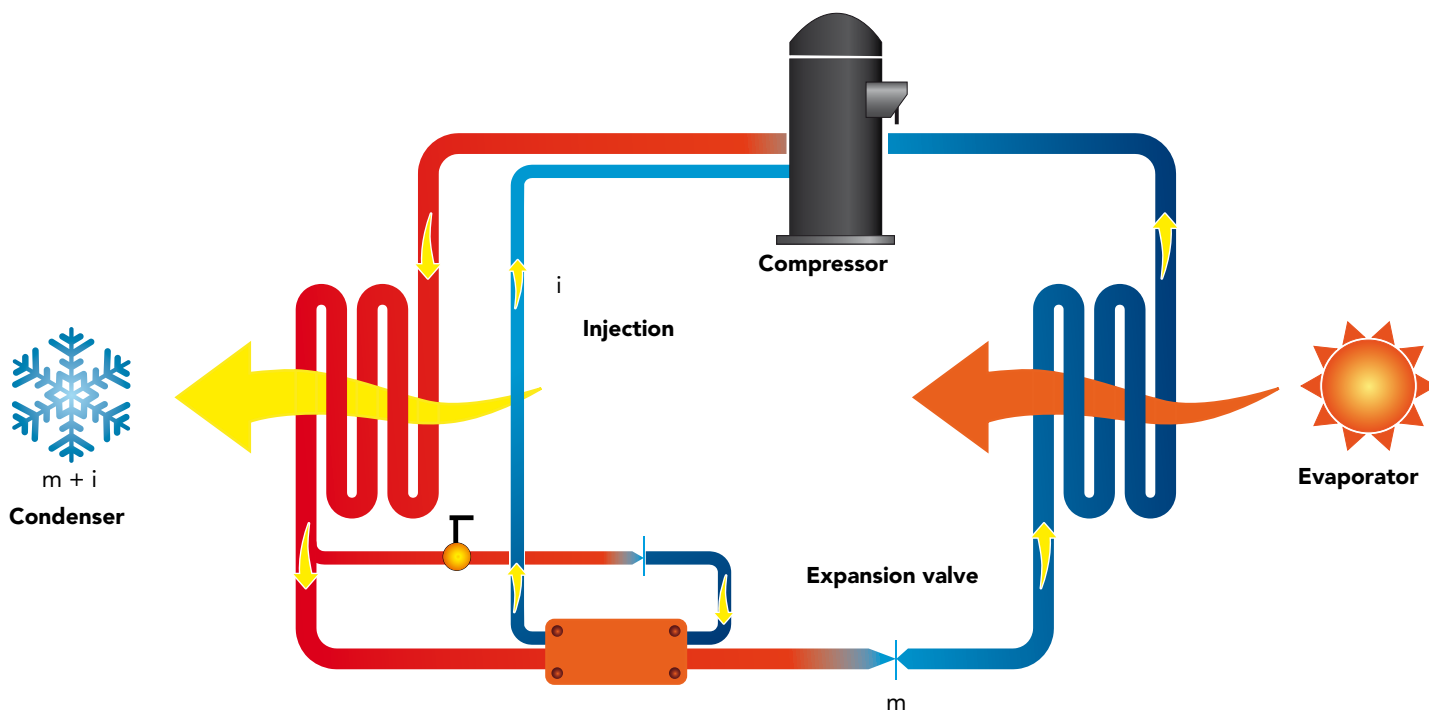
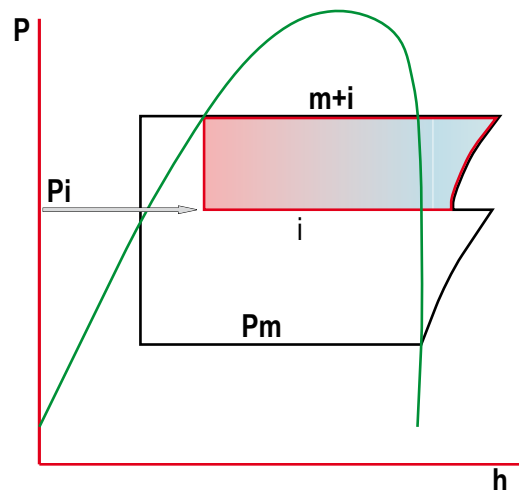

## COMPONENTS

### FRAME

All units are made from hot-galvanised sheet steel, painted with polyurethane powder enamel and stoved at 180°C to provide maximum protection against corrosion. The frame is self-supporting with removable panels. All screws and rivets used are made from stainless steel. The standard colour of the units is RAL9018.

### REFRIGERANT CIRCUIT

The refrigerant utilised is R410A. The refrigerant circuit is assembled using internationally recognised brand name components with all brazing and welding being performed in accordance with ISO 97/23. The refrigerant circuit includes: sight glass, filter drier, two thermal expansion valves (one for cooling mode, one for heating mode) with external equalizer, 4 way reversing valve, check valves, liquid receiver, Schrader valves for maintenance and control, pressure safety device (for compliance with PED regulations). The circuit also includes an AISI316 stainless steel heat exchanger that is used as an economizer plus an additional expansion valve for refrigerant vapour injection.

### COMPRESSORS

Units use scroll compressors that are equipped with E.V.I. technology, a versatile method of improving system capacity and efficiency. EVI stands for "Enhanced Vapour Injection." The technology involves injecting refrigerant vapour into the middle of the compression process, a procedure that significantly boosts capacity and efficiency. Each scroll compressor used in these units is similar to a two-stage compressor with built-in inter-stage cooling. The process begins when a portion of the condenser liquid is extracted and expanded through an expansion valve. The low temperature liquid/gas mixture produced is injected into a heat exchanger that operates as a sub cooler. Any liquid is evaporated and the vapour produced is superheated.

The superheated vapour is then injected into an intermediate port in the scroll compressor. This cold vapour reduces the temperature of the compressed gas thus enabling the compressor to raise the pressure to levels (and temperatures) beyond that possible with a single stage scroll. The additional sub cooling of the main volume of liquid refrigerant increases the evaporator capacity. This compressor technology generates a larger pressure ratio between condensing and evaporating pressures, with significant performance improvement. In all units the compressors are connected in tandem. The compressors are all supplied with a crankcase heater and thermal overload protection by a klixon embedded in the motor winding. They are mounted in a separate enclosure in order to be separated from the air stream thus enabling them to be maintained even if the unit is operating. Access to this enclosure is by the front panel of the unit. The crankcase heater is always powered when the compressor is in stand-by.

### SOURCE HEAT EXCHANGER

The source heat exchanger is made from copper pipes and aluminium fins. Dimensioning of the copper pipes and the aluminium fins is optimized in order to obtain excellent performance. The tubes are mechanically expanded into the fins in order to maximise heat transfer. Furthermore, the design guarantees a low air side pressure drop thus enabling the use of low rotation speed (and hence low noise) fans. All heat exchangers are supplied standard with fins hydrophilic coating.

### USER HEAT EXCHANGERS

The user heat exchanger is a braze welded, plate type heat exchanger, manufactured from AISI 316 stainless steel. The use of this type of exchanger results in a massive reduction of the refrigerant charge of the unit compared to a traditional shell-in-tube type. A further advantage is a reduction in the overall dimensions of the unit. The exchangers are factory insulated with flexible close cell material and can be fitted with an antifreeze

heater (accessory). Each exchanger is fitted with a temperature sensor on the discharge water side for antifreeze protection.

### FANS

The fans are direct drive axial type with aluminium aerofoil blades, are statically and dynamically balanced and are supplied complete with a safety fan guard complying with the requirements of EN 60335. They are fixed to the unit frame via rubber antivibration mountings. In the LS versions the fans are 6 poles type (approx 900 rpm), in the XL versions the fans are 8 poles type (approx 600 rpm), in the NN versions the fans are 12 poles type (approx 450 rpm). The motors are fitted with integrated thermal overload protection and have a moisture protection rating of IP 54.

### MICROPROCESSORS

All units are supplied as standard complete with control panel. The microprocessor controls the following functions: control of the water temperature, antifreeze protection, compressor timing, compressor automatic starting sequence (For multiple compressors), alarm reset.

The control panel is supplied with display showing all operational icons. The microprocessor is set for automatic defrost (when operating in severe ambient conditions) and for summer/ winter change over (only for RV versions).

The control also manages the anti-legionella program, the integration with other heating sources (electric heaters, boilers, solar panels etc), the operation of a three port modulating valve (for diverting to DHW or heating) and both the heating circuit pump and the domestic hot water circuit pump. If required (available as an option), the microprocessor can be configured in order for it to connect to a site BMS system thus enabling remote control and management.

### ELECTRIC ENCLOSURE

The enclosure is manufactured in order to comply with the requirements of the electromagnetic compatibility standards CEE EN60204. Access to the enclosure is achieved by removing the front panel of the unit. The following components are supplied as standard on all units: main switch, a sequence relay that disables the power supply in the event that the phase sequence is incorrect (scroll compressors can be damaged if they rotate in the wrong direction), thermal overloads (protection of pumps and fans), overload switches, control circuit automatic breakers, compressor contactors, automatic switches and pump contactors. The terminal board has volt free contacts for remote ON-OFF, Summer/ winter change over (heat pumps only) and general alarm.

### CONTROL AND PROTECTION DEVICES

All units are supplied with the following controls and protections: user water return temperature sensor, antifreeze protection temperature sensor installed on users water output, domestic hot water supply and return temperature sensors (only versions P2S), high pressure manual reset, low pressure automatic reset, compressor thermal protection, air fan, thermal protection, pressure transducer (used to optimize the defrost cycle and to adjust the fan speed depending on ambient conditions), flow switch. All units are also fitted with a temperature probe sensor with "Energy Saving" function, supplied in a separate plastic box, which can be used to stop the pump use during periods of stand-by, when the water temperature reaches the set point. Doing this the power consumption of the unit is strongly reduced. The probe sensor must be positioned in the hydraulic compensator present at the screening technique. The domestic hot water circuit (only versions P2S) is already equipped with this probe, but it must be installed in the user circuit.

## VERSIONS

### HH Version

HH heating only versions are available in the P2U and P2S configuration only.

### RV Version

This version uses 2 hydraulic connections and is able to produce hot water in winter and cold water in summer. The unit is combined with a 2-pipe system.

### SA Version

Standard efficiency version, according to current standard. Unit equipped with AC fans.

### SE Version

Standard efficiency version, according to current standard. Unit equipped with EC fans.

### HA Version

High efficiency version, according to current standard. Unit equipped with AC fans.

### HE Version

High efficiency version, according to current standard. Unit equipped with EC fans.

### LS Version

This version includes the complete acoustic insulation of the unit with compressor jackets and insulating material made with high density media and the interposition of heavy bitumen layer.

### P2U Version

This is a two pipe version that can produce hot water for heating (HH heating only) and hot or cold water in the RV version. The RV is used with two pipe water based change-over systems. It is not able to produce domestic hot water.

### P2S Version

This is a two pipe version that can, in addition to producing hot water for heating (HH version) and hot and cold water in the RV version can also generate domestic hot water. The controller has dual heating set points (heating and DHW) and can also control a three port diverting valve that directs the DHW to the cylinder. DHW production has priority irrespective of the mode of operation of the unit. The unit is normally used with two pipe water based change-over systems.

### Super low noise and ultra low noise versions XL and NN

All units in XL and NN versions are supplied, as standard, with the latest 'Floating Frame' technology that completely isolates the compressors from the main casing, thereby eliminating vibration and noise from this source. The 'Floating Frame' is a special vibration and acoustic damping system that consists of a base plate and acoustic enclosure that houses the compressors. The base plate is separated from the supporting frame of the unit by soft steel springs that have a high damping power. Within the enclosure, the compressors are mounted on rubber shock absorbers on the floating base plate. The enclosure is manufactured from galvanized steel sandwich panels that have a micro-perforated inner skin and a core of 30 mm thick, high density (25 kg/m<sup>3</sup>). The entire arrangement provides a double damping system and acoustic attenuation. The compressor refrigerant pipes are connected to the refrigerant circuit through "anaconda" flexible connections. Flexible connections are also used on the water pipework within the unit. The combination of these systems results in an overall noise reduction in the region of 6-8 dB(A).

## OPERATION LIMITS

(SA/SE versions)

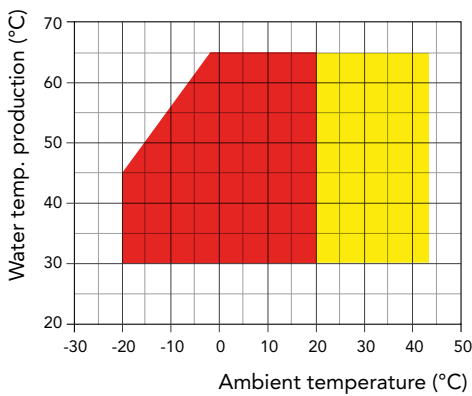

(HA/HE versions)

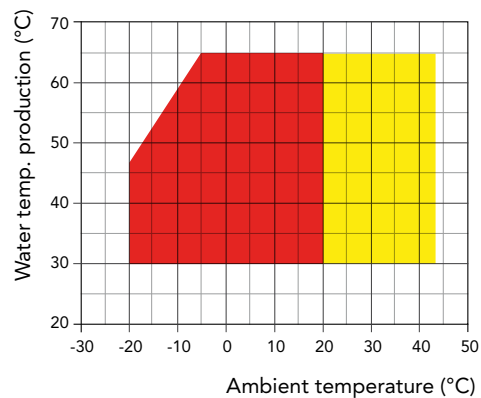

(RV versions Only)

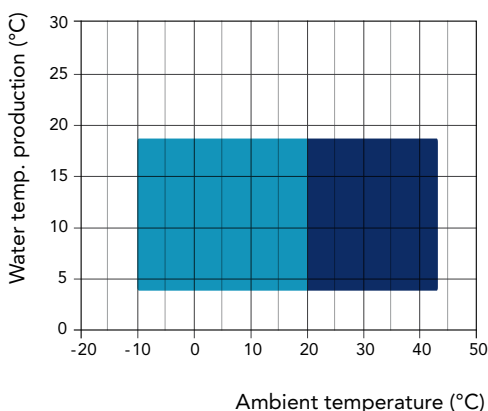

- Heating mode
- Heating mode with head pressure control (DCCF)
- Cooling with head pressure control (DCCF)
- Cooling mode

# ACCESSORIES

LZT

LZT		242 / 252	292 / 302	312	432	452	492	502	592	602
Flow switch		●	●	●	●	●	●	●	●	●
"Floating frame" Technology - LS Version		-	-	-	-	-	-	-	-	-
"Floating frame" Technology - XL - NN Version		●	●	●	●	●	●	●	●	●
E.C. fans - SA/LS versions	VECE	-	-	-	-	-	-	-	-	-
E.C. fans - SE/LS versions	VECE	●	●	●	●	●	●	●	●	●
E.C. fans - HA/LS - HA/XL versions	VECE	-	-	-	-	-	-	-	-	-
E.C. fans - HE/LS - HE/XL - HE/NN versions	VECE	●	●	●	●	●	●	●	●	●
Condensate discharge drip tray with antifreeze heater	BRCA	○	○	○	○	○	○	○	○	○
Cond.pressure control - transducer & EC Fans (only for SE and HE)	VECE	●	●	●	●	●	●	●	●	●
Fans regulation by phase cut (only SA - HA)	DCCF	X	X	X	X	X	X	X	X	X
Antifreeze kit for 2 pipe units	RAEV2	○	○	○	○	○	○	○	○	○
Electronic soft starter	DSSE	○	○	○	○	○	○	○	○	○
Serial interface card RS485	INSE	●	●	●	●	●	●	●	●	●
Rubber anti-vibration mountings	KAVG	○	○	○	○	○	○	○	○	○
Remote control panel	PCRL	○	○	○	○	○	○	○	○	○
Electronic expansion valve	VTEE	○	○	○	○	○	○	○	○	○
Cascade control system via RS485	SGRS	○	○	○	○	○	○	○	○	○
Hydraulic kit with one pump with tank *	A1ZZU	○	○	○	○	○	○	○	○	○
Hydraulic kit with two pumps with tank *	A2ZZU	○	○	○	○	○	○	○	○	○
Hydraulic kit with one pump without tank *	A1NTU	○	○	○	○	○	○	○	○	○
Hydraulic kit with two pumps without tank *	A2NTU	○	○	○	○	○	○	○	○	○

\* Not available for NN versions

X Necessary for P2S version  
Optional for P2U version

● Standard ○ Optional - Not available

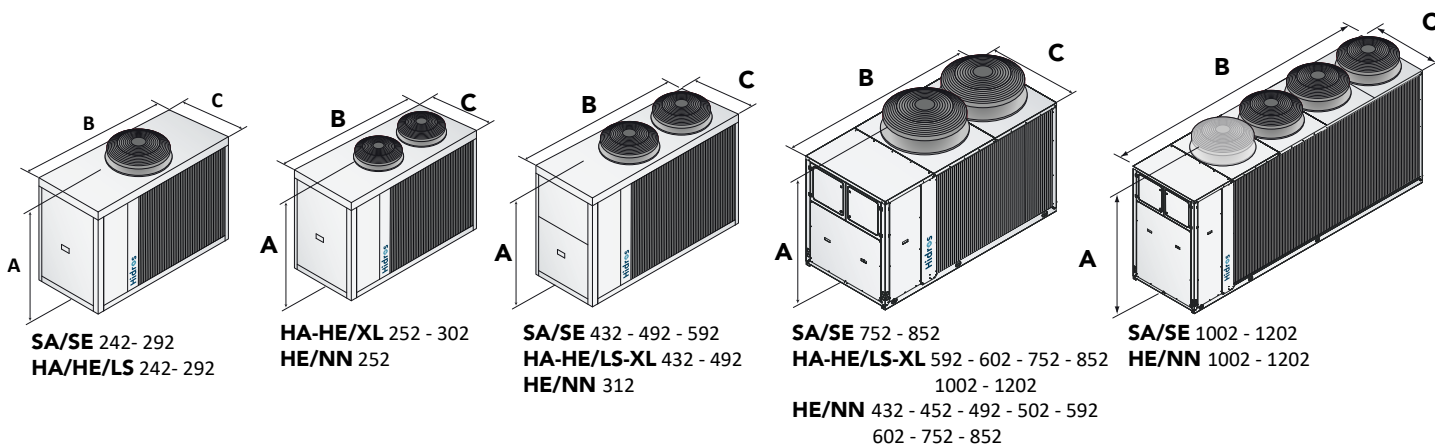

		242/252	292/302	312	432	452	492	502	592	602
A (mm)	SA-SE/LS	1500	1500	--	1690	--	1690	--	1690	--
B (mm)	SA-SE/LS	1915	1915	--	2400	--	2400	--	2400	--
C (mm)	SA-SE/LS	875	875	--	1150	--	1150	--	1150	--
kg	SA-SE/LS	1000	1000	--	1500	--	1500	--	1500	--
A (mm)	HA-HE/LS	1500	1500	--	1690	--	1690	--	--	1820
B (mm)	HA-HE/LS	1915	1915	--	2400	--	2400	--	--	2905
C (mm)	HA-HE/LS	875	875	--	1150	--	1150	--	--	1150
kg	HA-HE/LS	1000	1000	--	1500	--	1500	--	--	1060
A (mm)	HA-HE/XL	1500	1500	--	1690	--	1690	--	--	1820
B (mm)	HA-HE/XL	1915	1915	--	2400	--	2400	--	--	2905
C (mm)	HA-HE/XL	875	875	--	1150	--	1150	--	--	1150
kg	HA-HE/XL	1000	1000	--	1500	--	1500	--	--	1080
A (mm)	HE/NN	1500	--	1690	--	1820	--	1880	--	1880
B (mm)	HE/NN	1915	--	2400	--	2905	--	2905	--	2905
C (mm)	HE/NN	875	--	1150	--	1150	--	1150	--	1150
kg	HE/NN	1000	--	1500	--	1080	--	1100	--	1110

LZT		752	852	1002	1202	1454	1654	1854	2154
Flow switch		●	●	●	●	●	●	●	●
"Floating frame" Technology - LS Version		-	-	-	-	-	-	-	-
"Floating frame" Technology - XL - NN Version		●	●	●	●	●	●	●	●
E.C. fans - SA/LS versions	VECE	-	-	-	-	-	-	-	-
E.C. fans - SE/LS versions	VECE	●	●	●	●	●	●	●	●
E.C. fans - HA/LS - HA/XL versions	VECE	-	-	-	-	-	-	-	-
E.C. fans - HE/LS - HE/XL - HE/NN versions	VECE	●	●	●	●	●	●	●	●
Condensate discharge drip tray with antifreeze heater	BRCA	○	○	○	○	○	○	○	○
Cond.pressure control - transducer & EC Fans (only for SE and HE)	VECE	●	●	●	●	●	●	●	●
Fans regulation by phase cut (only SA - HA)	DCCF	X	X	X	X	X	X	X	X
Antifreeze kit for 2 pipe units	RAEV2	○	○	○	○	○	○	○	○
Electronic soft starter	DSSE	○	○	○	○	○	○	○	○
Serial interface card RS485	INSE	●	●	●	●	●	●	●	●
Rubber anti-vibration mountings	KAVG	○	○	○	○	○	○	○	○
Remote control panel	PCRL	○	○	○	○	○	○	○	○
Electronic expansion valve	VTEE	○	○	○	○	○	○	○	○
Cascade control system via RS485	SGRS	○	○	○	○	○	○	○	○
Hydraulic kit with one pump with tank *	A1ZZU	○	○	○	○	○	○	○	○
Hydraulic kit with two pumps with tank *	A2ZZU	○	○	○	○	○	○	○	○
Hydraulic kit with one pump without tank *	A1NTU	○	○	○	○	○	○	○	○
Hydraulic kit with two pumps without tank *	A2NTU	○	○	○	○	○	○	○	○

\* Not available for NN versions

X Necessary for P2S version  
Optional for P2U version

● Standard ○ Optional - Not available

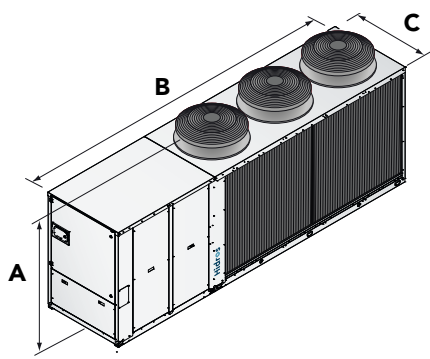

**HA-HE/LS** 1454 - 1654  
1854 - 2154

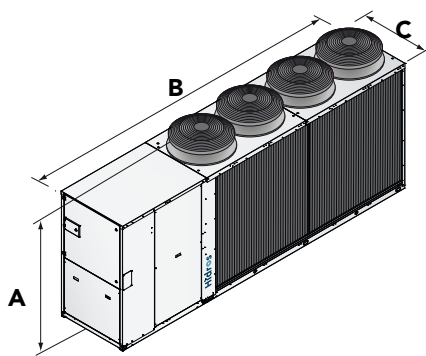

**SA-SE/LS** 1454 - 1654  
1854 - 2154

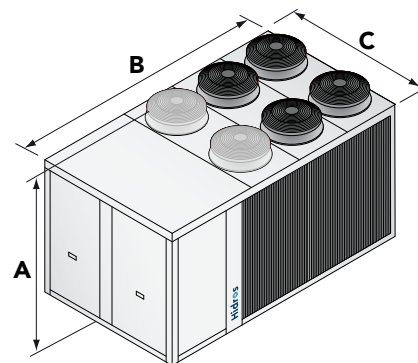

**HA-HE/XL** 1454 - 1654 - 1854 - 2154  
**HE/NN** 1454 - 1654 - 1854 - 2154

		752	852	1002	1202	1454	1654	1854	2154
A (mm)	SA-SE/LS	1880	1880	1890	1890	2310	2310	2310	2310
B (mm)	SA-SE/LS	2905	2905	3905	3905	5300	5300	5300	5300
C (mm)	SA-SE/LS	1150	1150	1150	1150	1150	1150	1150	1150
kg	SA-SE/LS	2000	2000	2000	2000	2500	2540	2580	2620
A (mm)	HA-HE/LS	1880	1880	1880	1880	1895	1895	1895	1895
B (mm)	HA-HE/LS	2905	2905	2905	2905	4695	4695	4695	4695
C (mm)	HA-HE/LS	1150	1150	1150	1150	1150	1150	1150	1150
kg	HA-HE/LS	2000	2000	2000	2000	2580	2640	2720	2760
A (mm)	HA-HE/XL	1880	1880	1880	1880	2350	2350	2350	2350
B (mm)	HA-HE/XL	2905	2905	2905	2905	4205	4205	4205	4205
C (mm)	HA-HE/XL	1150	1145	1150	1150	2210	2210	2210	2210
kg	HA-HE/XL	2000	2000	2000	2000	2500	2540	2580	2620
A (mm)	HE/NN	1880	1880	1890	1890	2350	2350	2350	2350
B (mm)	HE/NN	2905	2905	3905	3905	4205	4205	4205	4205
C (mm)	HE/NN	1150	1145	1150	1150	2210	2210	2210	2210
kg	HE/NN	2000	2000	2000	2000	2750	2800	2840	2890

# LZTi

## HEAT PUMPS AIR/WATER

DC INVERTER COMPRESSOR WITH VAPOR INJECTION (EVI)

Heating power from 7 kW to 19 kW

R410A

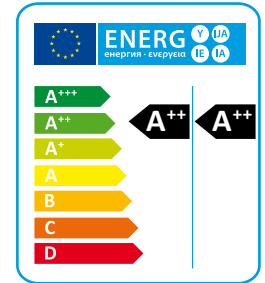

The LZTi series of high efficiency heat pumps has been specifically designed for use with radiant floor heating systems or those applications where it is necessary to have maximum efficiency when heating.

They have been optimized on heating mode, are able to produce water up to 65°C and can operate down to -20°C ambient temperature.

LZTi units are available in 2 or 4 pipe (SW6) versions. Both versions can produce domestic hot water, in the standard LZTi through the activation of an external 3-way-valve and in the SW6 version by means of a separate heat exchanger and hydraulic circuit for the domestic hot water.

All models are supplied as standard with a reversing valve for defrost and cold water production in summer.

### VERSIONS

**STD** 2 pipes reversible standard.

**SW6** 4 pipes unit capable of producing hot and cold water at the same time on two independent hydraulic circuits.



LZTi - LZTi/SW6		09	11	16	21
Heating capacity (EN14511) <sup>(1)</sup>	kW	7,7	9,6	15,0	19,0
Total input power (EN14511) <sup>(1)</sup>	kW	1,8	2,3	3,4	4,5
COP (EN14511) <sup>(1)</sup>	W/W	4,28	4,17	4,41	4,22
Energy Class in low temperature <sup>(2)</sup>		A++	A++	A++	A++
SCOP low temperature <sup>(2)</sup>	kWh/ kWh	4,05	4,08	4,27	4,16
ns,h low temperature <sup>(2)</sup>	%	153,8	155,8	157,3	157,8
Energy Class in medium temperature <sup>(2)</sup>		A+	A+	A++	A++
SCOP medium temperature <sup>(2)</sup>	kWh/ kWh	3,39	3,46	3,61	3,54
ηs,h medium temperature <sup>(2)</sup>	%	132,0	135,0	142,0	139,0
Cooling capacity (EN14511) <sup>(3)</sup>	kW	7,1	8,5	13,5	16,0
Total input power (EN14511) <sup>(3)</sup>	kW	2,3	2,8	4,2	5,1
EER (EN14511) <sup>(3)</sup>	W/W	3,10	3,04	3,21	3,14
Power supply	V/Ph/Hz	230/1/50	230/1/50	400/3+N/50	400/3+N/50
Max input current standard unit	A	21,9	21,9	15,8	15,8
Peak current standard unit	A	31,0	31,0	22,8	22,8
Fans	n°	1	1	2	2
Compressors	n°	1 E.VI. DC inverter	1 E.VI. DC inverter	1 E.VI. DC inverter	1 E.VI. DC inverter
Global warming potential (GWP)		2088	2088	2088	2088
Refrigerant charge	kg	3,3	3,3	4,3	4,3
Equivalent CO <sub>2</sub> charge	t	6,9	6,9	9,0	9,0
Sound power <sup>(4)</sup>	dB (A)	68	68	74	74
Sound pressure <sup>(5)</sup>	dB (A)	40	40	46	46

Performances are referred to the following conditions:

(1) Heating: Ambient temperature 7°C DB, 6°C WB, water temperature 30/35°C.

(2) Average conditions, low temperature, variable - Reg EU 811/2013.

(3) Cooling: ambient temperature 35°C, water temperature 12/7°C.

(4) Sound power level in accordance with ISO 3744.

(5) Sound pressure level at 10 mt from the unit in free field conditions in accordance with ISO 3744.

## COMPONENTS

### FRAME

All units are made from hot-galvanised sheet steel, painted with polyurethane powder enamel and stoved at 180°C to provide maximum protection against corrosion. The frame is self-supporting with removable panels. All screws and rivets used are made from stainless steel.

The standard colour of the units is RAL9018.

### REFRIGERANT CIRCUIT

The refrigerant circuit is made by using components from leading international companies in accordance with ISO 97/23 for the of braze welding processes.

The refrigerant used is R410A.

The refrigerant circuit includes: sight glass, filter drier, electronic expansion valve, 4-way valve, check valves, liquid receiver, Schrader valves for maintenance and control, a safety device (according to PED regulation).

The units are also equipped with plate heat exchanger AISI316 used as economizer circuit and additional thermostatic steam injection.

### COMPRESSORS

The compressors are high-efficiency scroll type, variable-speed modulation capability through DC inverter, supplied with a special design that increases the efficiency of the refrigeration cycle under conditions of very low ambient temperature.

The units are equipped with an economizer and a steam injection system, a versatile method to improve the capacity and efficiency of the system.

The technology of steam injection, consists into injecting the refrigerant vapor in the middle of the compression process, to increase significantly the capabilities and efficiencies too.

The compressors are equipped with an innovative electric motor permanent magnet brushless DC inverter-driven, high-efficiency, are all equipped with electrical resistance and thermal overload protection.

### SOURCE HEAT EXCHANGER

The source heat exchanger is made from 3/8" copper pipes and 0,1mm thick aluminium fins with the tubes being mechanically expanded into the aluminium fins in order to maximise heat transfer. Furthermore, the design guarantees a low air side pressure drop thus enabling the use of low rotation speed (and hence low noise) fans.

### USER HEAT EXCHANGERS

The user heat exchanger is a braze welded, plate type heat exchanger, manufactured from AISI 316 stainless steel. Utilisation of this type of exchanger results in a massive reduction of the refrigerant charge of the unit compared to a traditional shell-in-tube type. A further advantage is a reduction in the overall dimensions of the unit.

The exchangers are factory insulated with flexible close cell material and can be fitted with an antifreeze heater (accessory). Each exchanger is fitted with a temperature sensor on the discharge water side for antifreeze protection.

### HIGH EFFICIENCY AXIAL FANS

High efficiency E.C. axial fans, supplied with Brushless DC electric motors electronically commutated (E.C. motors) able to grants the highest energy efficiency class, according to the latest EU specifications, with the result of substantial energy consumption reduction for ventilation and noise reduction thanks to the new ultra efficient blade profiling. The fans are statically and dynamically balanced and supplied complete with a safety fan guard complying with the requirements of EN 60335. The fans are installed using a special steel profiled beam who minimize all vibrations transmitted to the frame and can modulate their speed till very low values, reducing in this way the electrical consumptions and the noise level during most of their operation. On all units we can control evaporating/condensing pressure by reading the pressure transducer and the continuous modulation of the EC fans rotation speed. The motors have a moisture protection rating of IP 54.

## MICROPROCESSORS

All units are supplied as standard with microprocessor controls. The microprocessor controls the following functions: control of the water temperature, antifreeze protection, compressor timing, compressor automatic starting sequence (For multiple compressors), alarm reset. The control panel is supplied with display showing all operational icons. The microprocessor is set for automatic defrost (when operating in severe ambient conditions) and for summer/ winter change over.

The control also manages the anti-legionella program, the integration with other heating sources (electric heaters, boilers, solar panels etc), the operation of a three port modulating valve (for diverting to DHW or heating) and both the heating circuit pump and the domestic hot water circuit pump. If required (available as an option), the microprocessor can be configured in order for it to connect to a site BMS system thus enabling remote control and management. The Hidros technical department can discuss and evaluate, in conjunction with the customer, solutions using MODBUS protocols.

## ELECTRIC ENCLOSURE

The enclosure is manufactured in order to comply with the requirements of the electromagnetic compatibility standards CEE EN60204. Access to the enclosure is achieved by removing the front panel of the unit. The following components are supplied as standard on all units: main switch, a sequence relay that disables the power supply in the event that the phase sequence is incorrect (scroll compressors can be damaged if they rotate in the wrong direction), thermal overloads (protection of pumps and fans), compressor fuses, control circuit automatic breakers, compressor contactors, fan contactors and pump contactors. The terminal board has volt free contacts for remote ON-OFF, Summer/ winter change over (heat pumps only) and general alarm.

## CONTROL AND PROTECTION DEVICES

All units are supplied with the following controls and protections: user water return temperature sensor, antifreeze protection temperature sensor installed on users water output, domestic hot water supply and return temperature sensors (only versions SW6), high pressure manual reset, low pressure automatic reset, compressor thermal protection, air fan, thermal protection, pressure transducer (used to optimize the defrost cycle and to adjust the fan speed depending on ambient conditions), flow switch. All units are also fitted with a temperature probe sensor with "Energy Saving" function, supplied in a separate plastic box, which can be used to stop the pump use during periods of stand-by, when the water temperature reaches the set point. Doing this the power consumption of the unit is strongly reduced.

## NOISE REDUCTION

All units are supplied, as standard, with the latest 'Floating Frame' technology that completely isolates the compressors from the main casing, thereby eliminating vibration and noise from this source. The 'Floating Frame' is a special vibration and acoustic damping system that consists of a base plate and acoustic enclosure that houses the compressors. The base plate is separated from the supporting frame of the unit by soft steel springs that have a high damping power. Within the enclosure, the compressors are mounted on rubber shock absorbers on the floating base plate. The enclosure is manufactured from galvanized steel sandwich panels that have a micro-perforated inner skin and a core of 30 mm thick, high density (25 kg/m<sup>3</sup>). The entire arrangement provides a double damping system and acoustic attenuation. The compressor refrigerant pipes are connected to the refrigerant circuit through "anaconda" flexible connections. Flexible connections are also used on the water pipework within the unit. The combination of these systems results in an overall noise reduction in the region of 6-8 dB(A).

## VERSIONS

### Unit with independent domestic hot water production (SW6)

This version is fitted with an additional heat exchanger, used as condenser, to produce domestic hot water irrespective of the operation mode of the unit. The activation of the additional heat exchanger is performed automatically by the microprocessor control when the domestic hot water temperature, measured by the sensor, is lower than the required set point. If, during the summer months, the unit is operating on cooling, this version can produce hot and cold water simultaneously. This version is equipped with return and supply domestic hot water sensors and an advanced control panel with specific software for management of the system priorities.

## OPERATION LIMITS

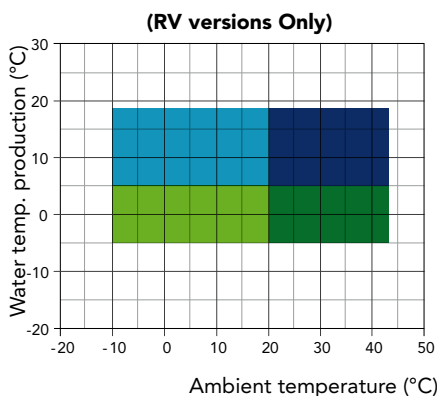
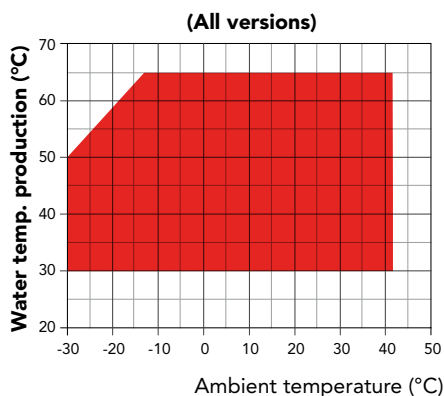

- Heating mode
- Cooling with head pressure control
- Cooling mode
- Cooling with head pressure control and glycol
- Cooling with glycol

## VERSIONS

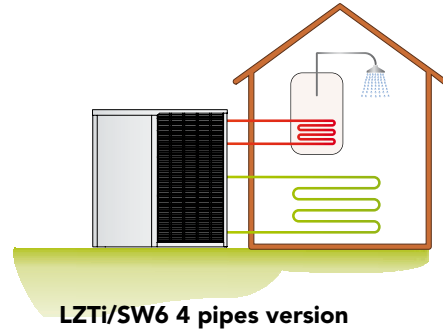
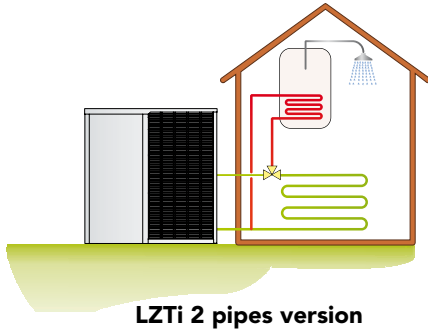

LZTi - LZTi/SW6		09	11	16	21
Main switch		●	●	●	●
Compressor automatic switch		●	●	●	●
Flow switch		●	●	●	●
Fans regulation by phase cut	DCCF	●	●	●	●
Fresh air temperature probe for set-point compensation	SOND	●	●	●	●
Specific software for operation priorities		●	●	●	●
Remote ON/OFF digital input		●	●	●	●
Summer/Winter digital input		●	●	●	●
Floating frame technology		●	●	●	●
Condensate discharge drip tray with antifreeze heater	BRCA	●	●	●	●
Electronic Expansion Valve	VTEE	●	●	●	●
Electronic Soft starter	DSSE	●	●	●	●
Remotable control panel		●	●	●	●
High efficiency fans		●	●	●	●
E1NT Hydraulic kit (pump only)	E1NT	○	○	○	○
Rubber anti-vibration mountings.	KAVG	○	○	○	○
Antifreeze kit	RAES	○	○	○	○
Serial interface card RS485 with MODBUS protocol	INSE	●	●	●	●

● Standard, ○ Optional, – Not available.

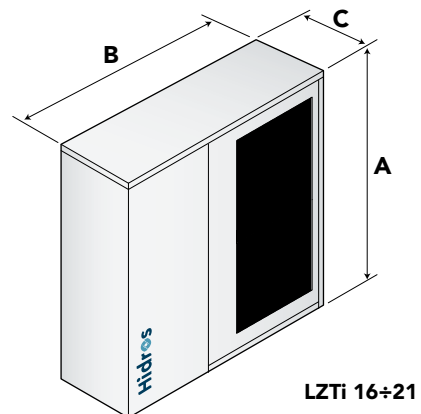
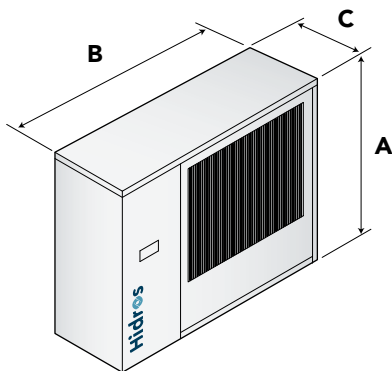

Mod.	A (mm)	B (mm)	C (mm)	kg
<b>09</b>	1250	1370	555	180
<b>11</b>	1250	1370	555	180

Mod.	A (mm)	B (mm)	C (mm)	kg
<b>16</b>	1450	1600	555	212
<b>21</b>	1450	1600	555	212

# WZT

## HIGH EFFICIENCY AIR TO WATER SPLIT SYSTEM HEAT PUMPS WITH E.V.I. COMPRESSORS

Heating capacity from 24 kW to 102 kW

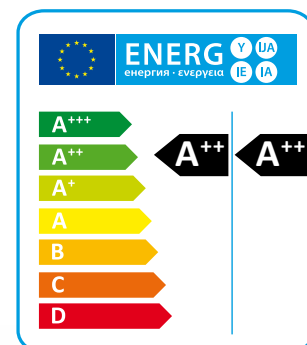

The air source high efficiency heat pumps WZT series, in the NN configuration, are particularly suitable for those applications where it is necessary to have maximum efficiency in heating mode and a noise level extremely low and, for this purpose, are provided in two sections, linked together by refrigerant lines, installing the compressor in the internal section. The units have been designed specifically to have the best possible efficiency, they may operate down to ambient temperatures of -20°C and produce hot water up to 65°C. The units are available in 2-pipe (P2S, P2U), version 2 + 2 pipe (P4S), and in version 4 pipe (P4U).

The units P2U are not able to produce sanitary hot water, the P2S versions are able to produce domestic hot water through the activation of an external 3-way valve (not supplied), while P4S versions and P4U too are able to produce hot water regardless of the mode unit is operating, through the activation of a specific refrigerating circuit. All models are equipped with reverse cycle valve for winter defrost mode, RV versions are also able to produce cold water in summer (not available for HH version).

The noise level is extremely contained thanks to the use

of a special floating system vibration damping that enables a reduction in terms of noise about 6-8 db (A) of compressors side and the fans in the combination with the specific number of turns extremely low (about 450 rpm).

### VERSIONS

- HH** Heating only.
- RV** Reversible heating/cooling.
- HE** High efficiency, EC fans.
- NN** Ultra low noise.
- P2U** 2 pipe systems without domestic hot water production.
- P2S** 2 pipe systems with domestic hot water production by external 3 way valve.
- P4U** 4 pipe systems heating/cooling.
- P4S** 2+2 pipe systems with domestic hot water production.

## TECHNICAL DATA

### Heating only version (HH)

HE/NN/HH		252	302	452	502	602	752	852	1002	1202
Heating capacity (EN14511) <sup>(1) *</sup>	kW	24,1	29,9	44,0	53,7	59,7	69,5	80,5	87,8	101,8
Total input power (EN14511) <sup>(1) *</sup>	kW	5,0	6,4	9,0	11,9	12,5	15,1	17,4	19,0	22,9
COP (EN14511) <sup>(1) *</sup>	W/W	4,86	4,66	4,91	4,50	4,78	4,61	4,63	4,62	4,44
Energy Class in low temperature <sup>(2) *</sup>		A++	A++	A++	A++	A++	A++	A++	A++	A++
SCOP low temperature <sup>(2) *</sup>	kWh/kWh	4,36	4,22	4,17	3,87	4,23	4,19	4,12	4,16	4,06
$\eta_{s,h}$ low temperature <sup>(2) *</sup>	%	171,4	165,6	163,8	151,6	166,1	164,6	161,9	163,3	159,3
Energy Class in medium temperature <sup>(2) *</sup>		A++	A++	A++	A++	A++	A++	A++	A++	A++
SCOP medium temperature <sup>(2) *</sup>	kWh/kWh	3,51	3,49	3,45	3,31	3,49	3,45	3,43	3,43	3,42
$\eta_{s,h}$ medium temperature <sup>(2) *</sup>	%	137,50	136,7	134,8	129,4	136,6	134,9	134,1	134,1	133,7
Nominal waterflow	l/h	4150	5148	7573	9228	10267	11951	13853	15095	17510
Power supply	V/Ph/Hz	400/3/50	400/3/50	400/3/50	400/3/50	400/3/50	400/3/50	400/3/50	400/3/50	400/3/50
Max input current standard unit	A	18,7	22,3	32,5	38,3	43,1	53,2	66,2	68,0	76,8
Peak current standard unit	A	61,1	81,4	117,5	147,7	140,2	167,2	207,7	209,0	209,0
Outdoor unit with single heat exchanger max airflow	m <sup>3</sup> /h	9000	9000	10000	16000	21000	21000	32000	32000	32000
Compressors / Circuits	n°/n°	2/1	2/1	2/1	2/1	2/1	2/1	2/1	2/1	2/1
Global warming potential (GWP)		2088	2088	2088	2088	2088	2088	2088	2088	2088
Refrigerant charge <sup>(7)</sup>	kg	9,0	9,0	14,5	23,0	23,0	27,0	36,0	36,0	36,0
Equivalent CO <sub>2</sub> charge	t	18,79	18,79	30,27	48,02	48,02	56,37	75,16	75,16	75,16
Sound power indoor unit <sup>(4)</sup>	dB (A)	67	68	69	69	69	69	71	71	71
Sound pressure indoor unit <sup>(5)</sup>	dB (A)	51	52	53	53	53	53	54	54	54
Sound power outdoor unit - single heat exchanger <sup>(4)</sup>	dB (A)	69	69	70	--	--	--	--	--	--
Sound power outdoor unit - single heat exchanger <sup>(6)</sup>	dB (A)	37	37	38	--	--	--	--	--	--
Sound power outdoor unit - double heat exchanger <sup>(4)</sup>	dB (A)	--	--	--	70	70	70	72	72	72
Sound power outdoor unit - double heat exchanger <sup>(6)</sup>	dB (A)	--	--	--	38	38	38	40	40	40

### Reversible heating/cooling version (RV)

HE/NN/RV		252	302	452	502	602	752	852	1002	1202
Heating capacity (EN14511) <sup>(1) *</sup>	kW	24,1	29,9	44,0	53,7	59,7	69,5	80,5	87,8	101,8
Total input power (EN14511) <sup>(1) *</sup>	kW	5,0	6,4	9,0	11,9	12,5	15,1	17,4	19,0	22,9
COP (EN14511) <sup>(1) *</sup>	W/W	4,86	4,66	4,91	4,50	4,78	4,61	4,63	4,62	4,44
Energy Class in low temperature <sup>(2) *</sup>		A++	A++	A++	A++	A++	A++	A++	A++	A++
SCOP low temperature <sup>(2) *</sup>	kWh/kWh	4,36	4,22	4,17	3,87	4,23	4,19	4,12	4,16	4,06
$\eta_{s,h}$ low temperature <sup>(2) *</sup>	%	171,4	165,6	163,8	151,6	166,1	164,6	161,9	163,3	159,3
Energy Class in medium temperature <sup>(2) *</sup>		A++	A++	A++	A++	A++	A++	A++	A++	A++
SCOP medium temperature <sup>(2) *</sup>	kWh/kWh	3,51	3,49	3,45	3,31	3,49	3,45	3,43	3,43	3,42
$\eta_{s,h}$ medium temperature <sup>(2) *</sup>	%	137,50	136,7	134,8	129,4	136,6	134,9	134,1	134,1	133,7
Nominal waterflow	l/h	4150	5148	7573	9228	10267	11951	13853	15095	17510
Cooling capacity (EN14511) <sup>(3) *</sup>	kW	19,6	24,1	34,8	42,7	49,7	57,6	66,0	73,1	84,4
Total input power (EN14511) <sup>(3) *</sup>	kW	6,7	9,3	11,5	14,8	16,6	20,5	23,0	24,8	30,6
EER (EN14511) <sup>(3) *</sup>	W/W	2,93	2,59	3,04	2,89	3,00	2,81	2,87	2,95	2,76
Power supply	V/Ph/Hz	400/3/50	400/3/50	400/3/50	400/3/50	400/3/50	400/3/50	400/3/50	400/3/50	400/3/50
Max input current standard unit	A	18,7	22,3	32,5	38,3	43,1	53,2	66,2	68,0	76,8
Peak current standard unit	A	61,1	81,4	117,5	147,7	140,2	167,2	207,7	209,0	209,0
Outdoor unit with single heat exchanger max airflow	m <sup>3</sup> /h	9000	9000	10000	16000	21000	21000	32000	32000	32000
Compressors / Circuits	n°/n°	2/1	2/1	2/1	2/1	2/1	2/1	2/1	2/1	2/1
Global warming potential (GWP)		2088	2088	2088	2088	2088	2088	2088	2088	2088
Refrigerant charge <sup>(7)</sup>	kg	9,0	9,0	14,5	23,0	23,0	27,0	36,0	36,0	36,0
Equivalent CO <sub>2</sub> charge	t	18,79	18,79	30,27	48,02	48,02	56,37	75,16	75,16	75,16
Sound power indoor unit <sup>(4)</sup>	dB (A)	67	68	69	69	69	69	71	71	71
Sound pressure indoor unit <sup>(5)</sup>	dB (A)	51	52	53	53	53	53	54	54	54
Sound power outdoor unit - single heat exchanger <sup>(4)</sup>	dB (A)	69	69	70	--	--	--	--	--	--
Sound power outdoor unit - single heat exchanger <sup>(6)</sup>	dB (A)	37	37	38	--	--	--	--	--	--
Sound power outdoor unit - double heat exchanger <sup>(4)</sup>	dB (A)	--	--	--	70	70	70	72	72	72
Sound power outdoor unit - double heat exchanger <sup>(6)</sup>	dB (A)	--	--	--	38	38	38	40	40	40

Performances are referred to the following conditions:

(1) Heating: Ambient temperature 7°C DB, 6°C WB, water temperature 30/35°C.

(2) Average conditions, variable - Reg EU 811/2013

(3) Cooling: ambient temperature 35°C, water temperature 12/7°C (RV versions only).

(4) Sound power level in accordance with ISO 3744.

(5) Sound pressure level at 1 mt from the unit in free field conditions, in accordance with ISO 3744.

(6) Sound pressure level at 10 mt from the unit in free field conditions, in accordance with ISO 3744.

(7) Without refrigerant lines content

\* Data referred to outdoor unit with single heat exchanger.

## COMPONENTS

### FRAME

All WZT units are made from hot-galvanised sheet steel, painted with polyurethane powder enamel and stoved at 180°C to provide maximum protection against corrosion. The frame is self-supporting with removable panels. All screws and rivets used are made from stainless steel. The standard colour of the units is RAL 9018.

### REFRIGERANT CIRCUIT

The refrigerant utilised is R410A. The refrigerant circuit is assembled using internationally recognised brand name components with all brazing and welding being performed in accordance with ISO 97/23. The refrigerant circuit includes: sight glass, filter drier, two thermal expansion valves (one for cooling mode, one for heating mode) with external equalizer, 4 way reversing valve, check valves, liquid receiver, Schrader valves for maintenance and control, pressure safety device (for compliance with PED regulations). The circuit also includes an AISI316 stainless steel heat exchanger that is used as an economizer plus an additional expansion valve for refrigerant vapour injection.

### COMPRESSORS

Scroll compressors equipped with E.V.I. technology, a versatile method of improving system capacity and efficiency. E.V.I. stands for "Economised Vapour Injection." The technology involves injecting refrigerant vapour into the middle of the compression process, a procedure that significantly boosts capacity and efficiency. Each scroll compressor used in these units is similar to a two-stage compressor with built-in inter-stage cooling. The process begins when a portion of the condenser liquid is extracted and expanded through an expansion valve. The low temperature liquid/gas mixture produced is injected into a heat exchanger that operates as a sub cooler. Any liquid is evaporated and the vapour produced is superheated.

The superheated vapour is then injected into an intermediate port in the scroll compressor. This cold vapour reduces the temperature of the compressed gas thus enabling the compressor to raise the pressure to levels (and temperatures) beyond that possible with a single stage scroll. The additional sub cooling of the main volume of liquid refrigerant increases the evaporator capacity. This compressor technology generates a larger pressure ratio between condensing and evaporating pressures, with significant performance improvement. The compressors are connected in tandem, they are all supplied with a crankcase heater and thermal overload protection by a klixon embedded in the motor winding. They are mounted in a separate enclosure in order to be separated from the air stream thus enabling them to be maintained even if the unit is operating. Access to this enclosure is by the front panel of the unit. The crankcase heater is always powered when the compressor is in stand-by.

### SOURCE HEAT EXCHANGER

The source heat exchanger is made from 3/8" copper pipes and 0.1mm thick aluminium fins with the tubes being mechanically expanded into the aluminium fins in order to maximise heat transfer. Furthermore, the design guarantees a low air side pressure drop thus enabling the use of low rotation speed (and hence low noise) fans.

### USER HEAT EXCHANGERS

The user heat exchanger is a braze welded, plate type heat exchanger, manufactured from AISI 316 stainless steel. Utilisation of this type of exchanger results in a massive reduction of the refrigerant charge of the unit compared to a traditional shell-in-tube type. A further advantage is a reduction in the overall dimensions of the unit.

The exchangers are factory insulated with flexible close cell material and can be fitted with an antifreeze heater (accessory). Each exchanger is fitted with a temperature sensor on the discharge water side for antifreeze protection.

### FANS

The fans are axial type with high performance aerofoil blades, the impeller is made of galvanized sheet galvanized, painted with polyurethane powder, to ensure a high protection in aggressive and severe environments. The impeller mounted directly on DC-brushless motor with external rotor, to ensure ideal cooling of the engine and a total absence of losses of the transmission. Impeller dynamically balanced in class 6.3 according to ISO 1940. Engine brushless-DC permanent magnet high efficiency electronic switching unit (driver) separate. Continuous speed variation with voltage signal 0-10 V, PFC integrated protection "burn out" (excessive drop in voltage), fully IP54 driver, serial interface with Modbus RTU communication protocol. The maximum rotation speed of the motor is 450 rpm to guarantee an extremely low noise level.

### MICROPROCESSORS

All units are supplied as standard with microprocessor controls. The microprocessor controls the following functions: control of the water temperature, antifreeze protection, compressor timing, compressor automatic starting sequence (For multiple compressors), alarm reset. The control panel is supplied with display showing all operational icons. The microprocessor is set for automatic defrost (when operating in severe ambient conditions) and for summer/winter change over. The control also manages the anti-legionella program, the integration with other heating sources (electric heaters, boilers, solar panels etc), the operation of a three port modulating valve (for diverting to DHW or heating) and both the heating circuit pump and the domestic hot water circuit pump. If required (available as an option), the microprocessor can be configured in order for it to connect to a site BMS system thus enabling remote control and management. The technical department can discuss and evaluate, in conjunction with the customer, solutions using MODBUS protocols.

### ELECTRIC ENCLOSURE

The enclosure is manufactured in order to comply with the requirements of the electromagnetic compatibility standards CEE EN60204. Access to the enclosure is achieved by removing the front panel of the unit. The following components are supplied as standard on all units: main switch, thermal overloads (protection of pumps and fans), compressor fuses, control circuit automatic breakers, compressor contactors, fan contactors and pump contactors.

The terminal board has volt free contacts for remote ON-OFF, Summer/Winter change over and general alarm.

For all three phase units, a sequence relay that disables the power supply in the event that the phase sequence is incorrect (scroll compressors can be damaged if they rotate in the wrong direction), is fitted as standard.

### CONTROL AND PROTECTION DEVICES

All units are supplied with the following control and protection devices: Return user water temperature sensor, antifreeze protection sensor installed on the user outlet water temperature, return and supply, high pressure switch with manual reset, low pressure switch with automatic reset, high pressure safety

valve, compressor thermal overload protection, fans thermal overload protection, pressure transducer (used to optimize the defrost cycle and the fan speed depending on the ambient conditions), flow switch.

## VERSIONS

### P2U Version

This is a two pipe version that can produce hot water for heating and cold water for cooling. The unit is used with two pipe water based change-over systems. It is not able to produce domestic hot water.

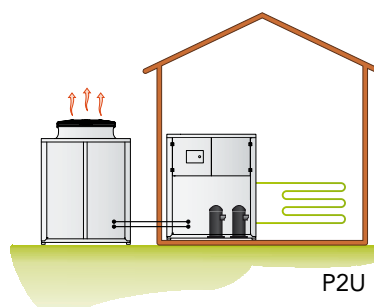

### P2S Version

This is a two pipe version that can, in addition to producing hot water for heating and cold water for cooling, also generate domestic hot water. The controller has dual heating set points (heating and DHW) and can also control a three port diverting valve that directs the DHW to the cylinder. DHW production has priority irrespective of the mode of operation of the unit. The unit is normally used with two pipe water based change-over systems.

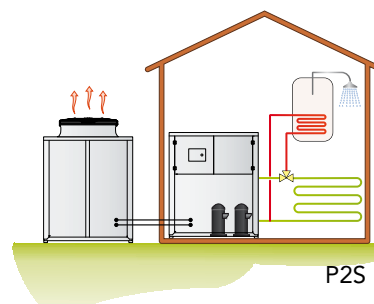

### P4S Version

This is a four pipe version that can produce hot water for heating, cold water for cooling and domestic hot water in all operational modes using an independent water circuit. When cooling, DHW generation is by heat recovery. This unit is normally used with two pipe water based change-over systems with the DHW circuit being separate.

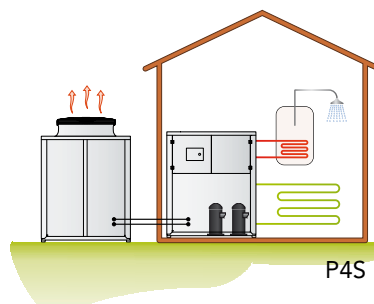

### P4U Version

This is a four pipe version that provides a modern approach to four pipe water based systems. Instead of using a boiler and chiller, this unit can generate hot water in one circuit, cold water in the other circuit either individually or simultaneously. When operating in simultaneous mode the heating capacity is equal to the cooling duty plus the power input to the compressors. The operating efficiency in this mode is extremely high. Domestic hot water production for this version is not available.

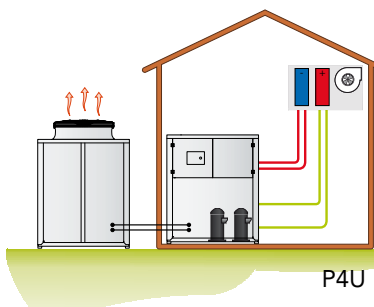

### Noise Reduction

All units are supplied, as standard, with the latest 'Floating Frame' technology that completely isolates the compressors from the main casing, thereby eliminating vibration and noise from this source. The 'Floating Frame' is a special vibration and acoustic damping system that consists of a base plate and acoustic enclosure that houses the compressors. The base plate is separated from the supporting frame of the unit by soft steel springs that have a high damping power. Within the enclosure, the compressors are mounted on rubber shock absorbers on the floating base plate. The enclosure is manufactured from galvanized steel sandwich panels that have a micro-perforated inner skin and a core of 30 mm thick, high density (25 kg/m<sup>3</sup>). The entire arrangement provides a double damping system and acoustic attenuation. The compressor refrigerant pipes are connected to the refrigerant circuit through "anaconda" flexible connections. Flexible connections are also used on the water pipework within the unit. The combination of these systems results in an overall noise reduction in the region of 6-8 dB(A).

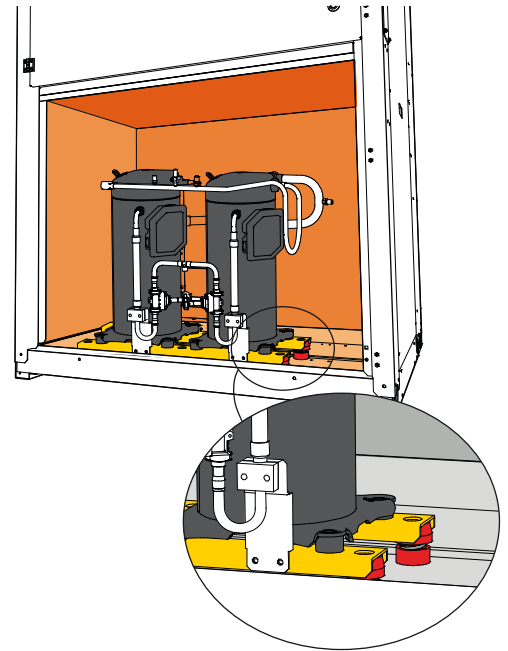

### OPERATION LIMITS

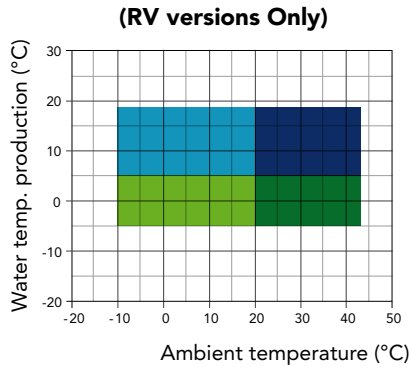
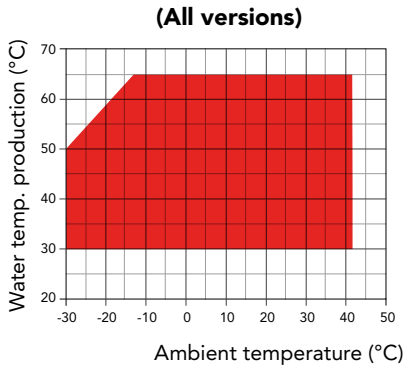

- Heating mode
- Cooling with head pressure control
- Cooling mode
- Cooling with head pressure control and glycol
- Cooling with glycol

### ACCESSORIES

WZT/NN		252	302	452	502	602	752	852	1002	1202
Main switch		●	●	●	●	●	●	●	●	●
Compressor automatic switch		●	●	●	●	●	●	●	●	●
Flow switch		●	●	●	●	●	●	●	●	●
Evap/cond pressure control by transducer and fan speed control		●	●	●	●	●	●	●	●	●
Fresh air temperature probe for set-point compensation		●	●	●	●	●	●	●	●	●
Specific software for operation priorities		●	●	●	●	●	●	●	●	●
Remote ON/OFF digital input		●	●	●	●	●	●	●	●	●
Summer/Winter digital input		●	●	●	●	●	●	●	●	●
Floating frame technology		●	●	●	●	●	●	●	●	●
Condensate tray with anti-freeze heater (outdoor section)	BRCA	●	●	●	●	●	●	●	●	●
E.C. fans - HE versions	VECE	●	●	●	●	●	●	●	●	●
Cascade control system via RS485	SGRS	○	○	○	○	○	○	○	○	○
Rubber anti-vibration mountings	KAVG	○	○	○	○	○	○	○	○	○
Evaporator antifreeze heater	RAEV2/4	○	○	○	○	○	○	○	○	○
Electronic soft starter	DSSE	○	○	○	○	○	○	○	○	○
Remote control panel	PCRL	○	○	○	○	○	○	○	○	○
Serial interface card RS485	INSE	●	●	●	●	●	●	●	●	●
Electronic thermostatic valve	VTEE	○	○	○	○	○	○	○	○	○

● Standard, ○ Optional, – Not Available.



**WZT - Indoor unit**

Mod.	A(mm)	B(mm)	C(mm)	kg
252	1600	800	1150	510
302	1600	800	1150	515
452	1600	800	1150	535
502	1600	800	1150	560
602	1600	800	1150	580
752	1600	800	1150	585
852	1600	800	1150	590
1002	1600	800	1150	600
1202	1600	800	1150	600

**Matching with outdoor unit**

Mod.
1
2
3
4
4
5
5
6
6

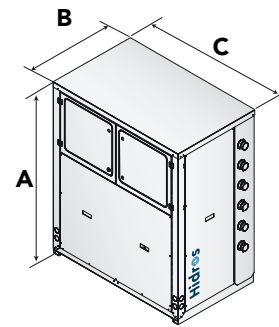

**EVV - Outdoor unit with single heat exchanger and vertical airflow**

Mod.	Fans (n°)	A(mm)	B(mm)	C(mm)	kg
1	2	1680	1615	875	242
2	2	1680	1615	875	263
3	2	1880	2115	1145	310

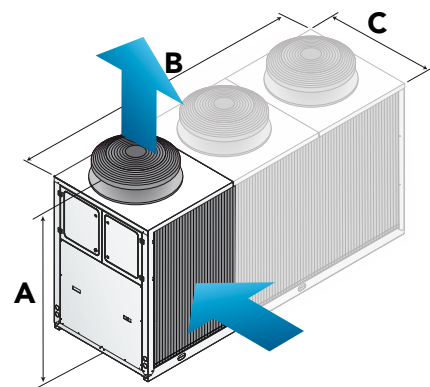

**EVR - Outdoor unit with double heat exchanger and vertical airflow**

Mod.	Fans (n°)	A(mm)	B(mm)	C(mm)	kg
4	2	1880	2115	1145	406
5	2	1880	2115	1145	425
6	3	1880	3115	1145	406

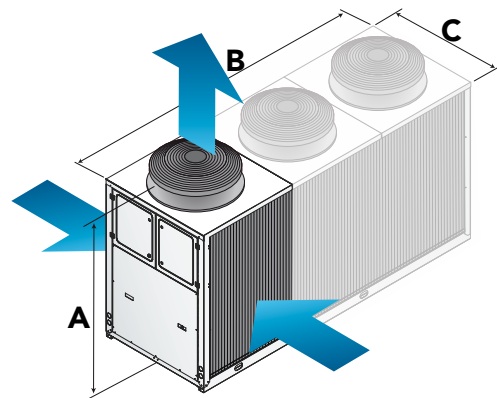

Heating capacity from 7 kW to 45 kW

R410A

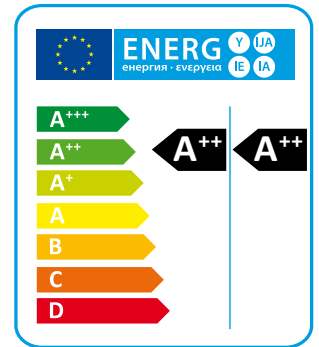

WZA heat pumps are particularly suitable for applications that utilise well water or ground source probes. These units have been designed for use with radiant heating systems or those applications where it is necessary to have maximum efficiency when heating. They have been optimized on heating mode and are able to produce water up to 60°C.

WZA heat pumps are available in several versions. The most simple is a 2 pipe unit that can provide heating only. By fitting an external 3 port valve the unit can provide either heating or domestic hot water. There is also a 4 pipe unit that produces domestic hot water in a separate hydraulic circuit and can generate this irrespective of whether the unit is in heating or cooling mode.

Differing versions and a wide range of accessories, enable the optimal solution to be selected.

### VERSIONS

- HH** Standard, heating only.
- RV** Reversible heating/cooling.
- P2U** 2 pipe systems without domestic hot water production.
- P4S** 2+2 pipe systems with domestic hot water production.
- PO** Unit designed for well water.
- GE** Unit designed for geothermal probe.

## TECHNICAL DATA

WZA - WZA/RV		06	08	12	16	20	24	33	40
Heating capacity (EN14511) <sup>(1)</sup>	kW	7,7	9,9	13,6	17,2	22,8	26,9	34,0	44,7
Input power (EN14511) <sup>(1)</sup>	kW	1,3	1,6	2,1	2,7	3,8	4,3	5,6	7,7
COP (EN14511) <sup>(1)</sup>	W/W	5,89	6,06	6,26	6,18	6,01	6,13	6,06	5,77
Energy Class in low temperature <sup>(2)</sup>		A++	A++	A++	A++	A++	A++	A++	A++
SCOP low temperature <sup>(2)</sup>	kWh/kWh	5,41	5,68	5,66	5,67	5,69	6,07	6,03	5,79
η <sub>s,h</sub> low temperature <sup>(2)</sup>	%	208,4	219,2	218,3	218,8	219,7	234,8	233,0	223,4
Energy Class in medium temperature <sup>(2)</sup>		A++	A++	A++	A++	A++	A++	A++	A++
SCOP medium temperature <sup>(2)</sup>	kWh/kWh	4,21	4,31	4,38	4,44	4,39	4,80	4,82	4,69
η <sub>s,h</sub> medium temperature <sup>(2)</sup>	%	160,5	164,4	167,1	169,6	167,6	184,1	184,9	179,4
Cooling capacity (EN14511) <sup>(3)</sup>	kW	5,5	7,1	9,9	12,6	16,7	19,8	25,3	33,4
Input power (EN14511) <sup>(3)</sup>	kW	1,4	1,8	2,4	3,0	4,1	4,8	6,0	8,2
EER (EN14511) <sup>(3)</sup>	W/W	3,78	3,88	4,14	4,16	4,06	4,13	4,16	4,04
Power supply	V/Ph/Hz	230/1/50	230/1/50	230/1/50	400/3+N/50	400/3+N/50	400/3+N/50	400/3+N/50	400/3+N/50
Peak current	A	60,0	83,0	51,5	62,0	75,0	58,9	71,7	88,0
Maximum input current	A	12,8	17,1	7,4	9,7	13,0	14,8	19,4	26,0
Compressors / Circuits	n°/n°	1 / 1	1 / 1	1 / 1	1 / 1	1 / 1	2 / 1	2 / 1	2 / 1
Refrigerant		R410A	R410A	R410A	R410A	R410A	R410A	R410A	R410A
Global warming potential (GWP)		2088	2088	2088	2088	2088	2088	2088	2088
Refrigerant charge	kg	2,2	2,2	2,9	2,9	4,6	4,6	5,0	5,5
Equivalent CO <sub>2</sub> charge	t	4,6	4,6	6,0	6,0	9,6	9,6	10,4	11,4
Sound power <sup>(4)</sup>	dB (A)	62	63	65	67	69	71	75	77
Sound pressure <sup>(5)</sup>	dB (A)	48	49	50	52	54	56	60	62

Performances are referred to the following conditions:

(1) Heating: User water temperature 30/35°C; Source water temperature 10/7°C.

(2) Variable - Reg EU 811/2013

(3) Cooling: User water temperature 12/7°C, Source water temperature 30/35°C.

(4) Sound power level in accordance with ISO 3744.

(5) Sound pressure level at 1 mt from the unit in free field conditions in accordance with ISO 3744.

## COMPONENTS

### FRAME

All units are made from hot-galvanised sheet steel, painted with polyurethane powder enamel and stoved at 180°C to provide maximum protection against corrosion. The frame is self-supporting with removable panels. All screws and rivets used are made from stainless steel.

### REFRIGERANT CIRCUIT

The refrigerant utilised is R410A. The refrigerant circuit is assembled using internationally recognised brand name components with all brazing and welding being performed in accordance with ISO 97/23. Each refrigerant circuit is totally independent from the other with the result that any fault or alarm condition on one circuit does not influence the other. The refrigerant circuit includes: sight glass, filter drier, electronic expansion valve, Schrader valves for maintenance and control and pressure safety device (for compliance with PED regulations).

### COMPRESSORS

The compressors used are a high performance scroll type that incorporates a special scroll design which enhances the efficiency of the refrigerant cycle when the source temperature is low. The compressors are all supplied with a crankcase heater and thermal overload protection by a klixon embedded in the motor winding. They are mounted in a separate enclosure thus enabling them to be maintained even if the unit is operating. Access

to this enclosure is via the front panel of the unit. The crankcase heater is always powered when the compressor is in stand-by.

### SOURCE SIDE HEAT EXCHANGERS

The source side heat exchanger is a braze welded, plate type heat exchanger, manufactured from AISI 316 stainless steel. It has a single water side circuit. Utilisation of this type of exchanger results in a massive reduction of the refrigerant charge of the unit compared to a traditional shell-in-tube type and increases the efficiency of the refrigerant cycle at part loads. The source heat exchangers are factory insulated with flexible close cell material and are provided with a temperature sensor for antifreeze protection.

### USER SIDE HEAT EXCHANGERS

The user side heat exchanger is a braze welded, plate type heat exchanger, manufactured from AISI 316 stainless steel. It has a single water side circuit. All units are supplied with a sub-cooler to enhance the performance of the refrigerant cycle. The user heat exchangers are factory insulated with flexible close cell material.

### MICROPROCESSORS

All units are supplied as standard with microprocessor controls. The microprocessor controls the following functions: control of the water temperature, antifreeze protection, compressor timing, compressor automatic starting sequence, alarm reset, volt free contact for remote general alarm, alarms and op-

eration LED's. If required (available as an option), the microprocessor can be configured in order for it to connect to a site BMS system thus enabling remote control and management. The Hidros technical department can discuss and evaluate, in conjunction with the customer, solutions using MODBUS protocols.

**ELECTRIC ENCLOSURE**

The enclosure is manufactured in order to comply with the requirements of the electromagnetic compatibility standards CEE EN60204. Access to the enclosure is achieved by removing the front panel of the unit. The following components are supplied as standard on all units: main switch, thermal overloads (protection of pumps), compressor fuses, control circuit automatic breakers, compressor contactors, fan contactors and pumps contactors.

The terminal board has volt free contacts for remote ON-OFF, Summer/Winter change over (reversible type only) and general alarm. For all three phase units, a sequence relay that disables the power supply in the event that the phase sequence is incorrect (scroll compressors can be damaged if they rotate in the wrong direction), is fitted as standard.

**CONTROL AND PROTECTION DEVICES**

All units are supplied with the following control and protection devices: Return and supply user heat exchanger sensors, return and supply source heat exchanger sensors, high pressure switch with manual reset, low pressure switch with automatic reset, high pressure safety valve, compressor thermal overload protection,

pump thermal overload protection, high and low pressure transducers, differential pressure switch on source and user circuit.

**HYDRAULIC KIT**

All units are supplied as standard with built-in hydraulic kit so configured:

User circuit: includes the inverter water pump, expansion vessel, filling connection, water drain and the water flow safety device (differential pressure switch). Source circuit: includes the inverter water pump, the water flow safety device (differential pressure switch), filling connection, water drain and expansion vessel. Domestic hot water circuit: includes the inverter water pump controlled by the microprocessor.

**ELECTRONIC THERMOSTATIC VALVE**

All the units are equipped with an electronic thermostatic valve, in order to optimise the functioning of the cooling circuit and to maximise the energy efficiency of the system in all operating conditions that can be implemented on the system.

**VERSIONS**

**WZA/HH**

Version for heating only applications.

**WZA/RV 2 pipes version**

This version is capable of cooling during summer operation by using a 4 way reversing valve in the refrigerant circuit.

**WZA/RV/P4S 4 pipes version**

This version is supplied with 4 pipes on the user side and is able to produce simultaneously, hot and cold water on 2 independent hydraulic circuits. On this version, the domestic hot water.

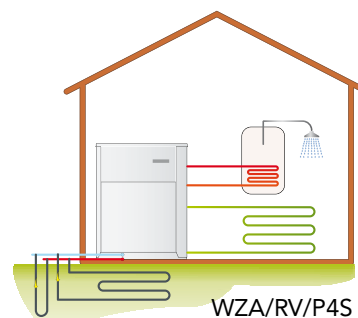
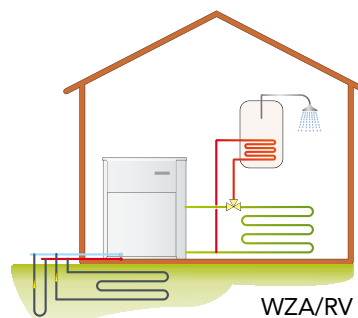

## ACCESSORIES

WZA - WZA/RV		06	08	12	16	20	24	33	40
Main switch		●	●	●	●	●	●	●	●
Microprocessor control		●	●	●	●	●	●	●	●
Water pumps ( source, user, domestic hot water pump)		●	●	●	●	●	●	●	●
Low noise version LS [-4dB(A) of STD]	LS00	○	○	○	○	○	○	○	○
Electronic soft starter	DSSE	○	○	○	○	○	○	○	○
Rubber anti-vibration mountings	KAVG	●	●	●	●	●	●	●	●
Remote control panel	PCRL	○	○	○	○	○	○	○	○
Serial interface card RS485	INSE	●	●	●	●	●	●	●	●

● Standard, ○ Optional, – Not available.

## OPERATION LIMITS

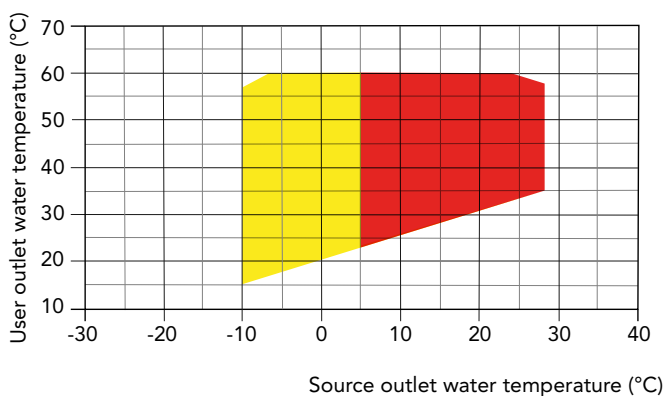

- Heating
- Heating with glycol source circuit

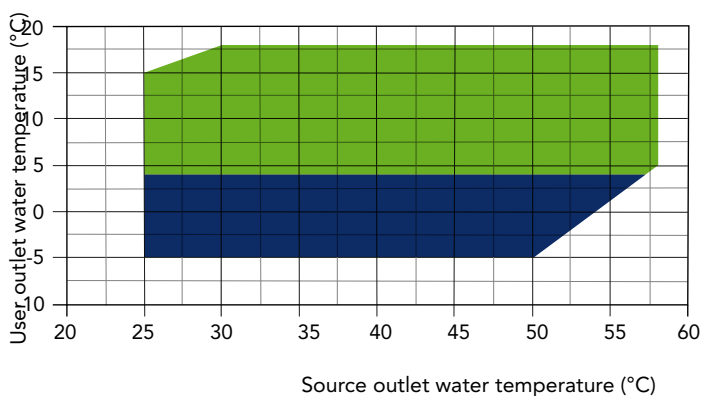

- Cooling
- Cooling with glycol user circuit

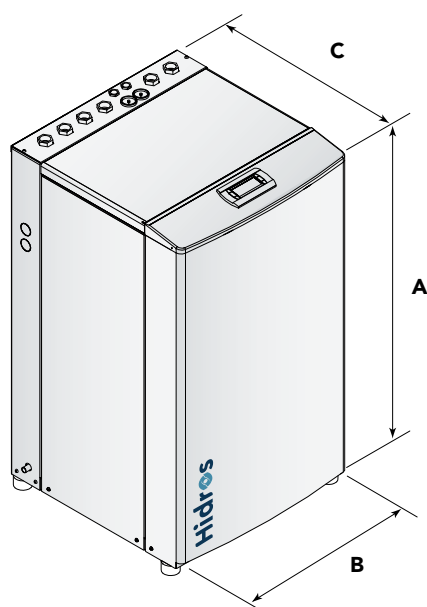

Mod.	A (mm)	B (mm)	C (mm)	kg
06	970	620	575	146
08	970	620	575	153
12	1050	620	650	169
16	1050	620	650	195
20	1050	620	650	215
24	1040	800	880	262
33	1040	800	880	302
40	1040	800	880	320

Heating capacity from 52 kW to 440 kW

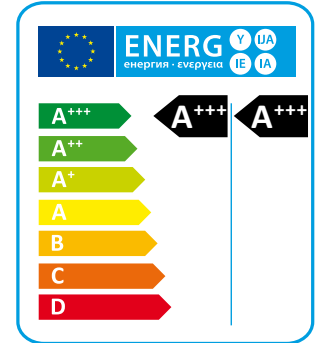

WHA heat pumps are particularly suitable for applications that utilise ground source probes. These units have been designed for use with radiant floor heating systems or those applications where it is necessary to have maximum efficiency when heating. They have been optimized on heating mode and are able to produce water up to 60°C. WHA heat pumps are available in several versions. The most simple is a 2 pipe unit that can provide heating only. By fitting an external 3 port valve the unit can provide either heating or domestic hot water. There is also a 4 pipe unit that produces domestic hot water in a separate hydraulic circuit and can generate this irrespective of whether the unit is in heating or cooling mode. All the WHA units are also available in Free Cooling (FC) versions which provide low energy cooling by simply using the cool water that is available from either the ground source probes or the well water.

Differing versions and a wide range of accessories, enable the optimal solution to be selected.

### VERSIONS

- Standard, heating only.
- RV** Reversible heating/cooling.
- SW5** Heating only + domestic hot water circuit.
- RV/SW6** Reversible version heating/cooling with independent DHW circuit.
- FC** Free cooling version (available in all versions).

## TECHNICAL DATA

Heating only version (HH)

HH		039	045	050	060	070	080	090	110	120
Heating capacity (EN14511) <sup>(1)</sup>	kW	51,7	59,0	71,2	80,0	92,5	105,9	120,8	136,1	152,0
Input power (EN14511) <sup>(1)</sup>	kW	9,8	11,0	12,5	14,3	16,9	19,4	22,2	24,9	28,3
COP (EN14511) <sup>(1)</sup>	W/W	5,27	5,36	5,69	5,59	5,47	5,45	5,44	5,46	5,37
Energy Class in low temperature <sup>(2)</sup>		A+++	A+++	A+++	A+++	A+++	A+++	A+++	A+++	A+++
SCOP low temperature <sup>(2)</sup>	kWh/kWh	5,21	5,52	5,51	5,77	5,60	5,50	5,44	5,44	5,46
η <sub>s,h</sub> low temperature <sup>(2)</sup>	%	200,4	212,8	212,5	222,9	215,8	212,0	209,4	209,5	210,5
Energy Class in medium temperature <sup>(2)</sup>		A+++	A+++	A+++	A+++	A+++	A+++	A+++	A+++	A+++
SCOP medium temperature <sup>(2)</sup>	kWh/kWh	4,32	4,50	4,51	4,67	4,54	4,51	4,45	4,47	4,48
η <sub>s,h</sub> medium temperature <sup>(2)</sup>	%	164,6	171,8	172,4	178,6	173,4	172,4	170,0	170,8	171,1
Power supply	V/Ph/Hz	400/3/50	400/3/50	400/3/50	400/3/50	400/3/50	400/3/50	400/3/50	400/3/50	400/3/50
Peak current	A	111,0	132,0	140,0	143,0	199,0	208,0	259,0	265,0	312,0
Max input current	A	32,0	42,0	44,0	50,0	59,0	68,0	74,0	80,0	88,5
Compressors / Circuits	n°/n°	2/1	2/1	2/1	2/1	2/1	2/1	2/1	2/1	2/1
Capacity steps	n°	2	2	2	2	2	2	2	2	2
Global warming potential (GWP)		2088	2088	2088	2088	2088	2088	2088	2088	2088
Refrigerant charge	kg	4,3	4,3	5,0	5,0	6,0	6,5	8,0	11,0	11,0
Equivalent CO <sub>2</sub> charge	t	9,0	9,0	10,4	10,4	12,5	13,6	16,7	23,0	23,0
Sound power <sup>(4)</sup>	dB(A)	71	77	77	78	79	80	83	85	87
Sound pressure <sup>(5)</sup>	dB(A)	55	61	61	62	63	64	66	68	70

HH		130	152	162	190	210	240	260	300	320
Heating capacity (EN14511) <sup>(1)</sup>	kW	169,2	195,0	222,1	243,8	271,3	306,9	342,2	390,9	439,4
Input power (EN14511) <sup>(1)</sup>	kW	31,6	36,8	41,0	45,1	51,0	57,3	63,6	72,5	81,4
COP (EN14511) <sup>(1)</sup>	W/W	5,35	5,29	5,41	5,40	5,32	5,35	5,38	5,39	5,39
Energy Class in low temperature <sup>(2)</sup>		A+++	A+++	A+++	A+++	A+++	A+++	A+++	A+++	A+++
SCOP low temperature <sup>(2)</sup>	kWh/kWh	5,42	5,49	5,64	5,47	5,45	5,47	5,51	5,55	5,49
η <sub>s,h</sub> low temperature <sup>(2)</sup>	%	208,8	211,7	217,6	210,6	209,9	210,6	212,5	214,1	211,6
Energy Class in medium temperature <sup>(2)</sup>		A+++	A+++	A+++	A+++	A+++	A+++	A+++	A+++	A+++
SCOP medium temperature <sup>(2)</sup>	kWh/kWh	4,50	4,53	4,62	4,53	4,54	4,55	4,58	4,60	4,59
η <sub>s,h</sub> medium temperature <sup>(2)</sup>	%	171,8	173,0	176,7	173,2	173,5	173,9	175,0	175,8	175,4
Power supply	V/Ph/Hz	400/3/50	400/3/50	400/3/50	400/3/50	400/3/50	400/3/50	400/3/50	400/3/50	400/3/50
Peak current	A	320,5	358,5	375,4	333,0	345,0	400,5	417,5	472,4	506,2
Max input current	A	97,0	113,9	130,8	148,0	160,0	177,0	194,0	227,8	261,6
Compressors / Circuits	n°/n°	2/1	2/1	2/1	4/2	4/2	4/2	4/2	4/2	4/2
Capacity steps	n°	2	2	2	4	4	4	4	4	4
Global warming potential (GWP)		2088	2088	2088	2088	2088	2088	2088	2088	2088
Refrigerant charge	kg	15,0	15,0	15,0	16,0	16,0	19,0	19,0	30,0	30,0
Equivalent CO <sub>2</sub> charge	t	31,3	31,3	31,3	33,4	33,4	39,7	39,7	62,6	62,6
Sound power <sup>(4)</sup>	dB(A)	88	88	88	86	88	90	91	91	91
Sound pressure <sup>(5)</sup>	dB(A)	71	71	71	69	71	73	74	74	74

Performances are referred to the following conditions:

(1) Heating: user water temperature 30/35°C, source water temperature 10/7°C.

(2) Average conditions, variable - Reg EU 811/2013

(3) Sound power level in accordance with ISO 3744. Operation mode 1, without water pumps.

(4) Sound pressure level at 1 mt from the unit in free field conditions in accordance with ISO 3744. Operation mode 1, without water pumps.

Reversible heating/cooling version (RV)

RV		039	045	050	060	070	080	090	110	120
Heating capacity (EN14511) <sup>(1)</sup>	kW	51,7	59,0	71,2	80,0	92,5	105,9	120,8	136,1	152,0
Input power (EN14511) <sup>(1)</sup>	kW	9,8	11,0	12,5	14,3	16,9	19,4	22,2	24,9	28,3
COP (EN14511) <sup>(1)</sup>	W/W	5,27	5,36	5,69	5,59	5,47	5,45	5,44	5,46	5,37
Energy Class in low temperature <sup>(2)</sup>		A+++	A+++	A+++	A+++	A+++	A+++	A+++	A+++	A+++
SCOP low temperature <sup>(2)</sup>	kWh/kWh	5,21	5,52	5,51	5,77	5,60	5,50	5,44	5,44	5,46
η <sub>s,h</sub> low temperature <sup>(2)</sup>	%	200,4	212,8	212,5	222,9	215,8	212,0	209,4	209,5	210,5
Energy Class in medium temperature <sup>(2)</sup>		A+++	A+++	A+++	A+++	A+++	A+++	A+++	A+++	A+++
SCOP medium temperature <sup>(2)</sup>	kWh/kWh	4,32	4,50	4,51	4,67	4,54	4,51	4,45	4,47	4,48
η <sub>s,h</sub> medium temperature <sup>(2)</sup>	%	164,6	171,8	172,4	178,6	173,4	172,4	170,0	170,8	171,1
Cooling capacity (EN14511) <sup>(3)</sup>	kW	42,9	49,0	60,3	67,4	77,5	88,9	101,3	114,3	126,9
Total input power (EN14511) <sup>(3)</sup>	kW	10,0	11,3	12,9	14,7	17,4	19,9	22,7	25,5	29,0
EER (EN14511) <sup>(3)</sup>	W/W	4,29	4,33	4,67	4,58	4,45	4,46	4,46	4,48	4,37
Free Cooling capacity <sup>(4)</sup>	kW	22,8	22,9	36,0	36,3	36,6	49,3	71,0	72,4	73,5
Power supply	V/Ph/Hz	400/3/50	400/3/50	400/3/50	400/3/50	400/3/50	400/3/50	400/3/50	400/3/50	400/3/50
Peak current	A	111,0	132,0	140,0	143,0	199,0	208,0	259,0	265,0	312,0
Max input current	A	32,0	42,0	44,0	50,0	59,0	68,0	74,0	80,0	88,5
Compressors / Circuits	n°/n°	2/1	2/1	2/1	2/1	2/1	2/1	2/1	2/1	2/1
Capacity steps	n°	2	2	2	2	2	2	2	2	2
Global warming potential (GWP)		2088	2088	2088	2088	2088	2088	2088	2088	2088
Refrigerant charge	kg	5,0	5,0	7,0	7,0	7,5	9,0	10,0	15,0	15,0
Equivalent CO <sub>2</sub> charge	t	10,4	10,4	14,6	14,6	15,7	18,8	20,9	31,3	31,3
Sound power <sup>(5)</sup>	dB(A)	71	77	77	78	79	80	83	85	87
Sound pressure <sup>(6)</sup>	dB(A)	55	61	61	62	63	64	66	68	70

RV		130	152	162	190	210	240	260	300	320
Heating capacity (EN14511) <sup>(1)</sup>	kW	169,2	195,0	222,1	243,8	271,3	306,9	342,2	390,9	439,4
Input power (EN14511) <sup>(1)</sup>	kW	31,6	36,8	41,0	45,1	51,0	57,3	63,6	72,5	81,4
COP (EN14511) <sup>(1)</sup>	W/W	5,35	5,29	5,41	5,40	5,32	5,35	5,38	5,39	5,39
Energy Class in low temperature <sup>(2)</sup>		A+++	A+++	A+++	A+++	A+++	A+++	A+++	A+++	A+++
SCOP low temperature <sup>(2)</sup>	kWh/kWh	5,42	5,49	5,64	5,47	5,45	5,47	5,51	5,55	5,49
η <sub>s,h</sub> low temperature <sup>(2)</sup>	%	208,8	211,7	217,6	210,6	209,9	210,6	212,5	214,1	211,6
Energy Class in medium temperature <sup>(2)</sup>		A+++	A+++	A+++	A+++	A+++	A+++	A+++	A+++	A+++
SCOP medium temperature <sup>(2)</sup>	kWh/kWh	4,50	4,53	4,62	4,53	4,54	4,55	4,58	4,60	4,59
η <sub>s,h</sub> medium temperature <sup>(2)</sup>	%	171,8	173,0	176,7	173,2	173,5	173,9	175,0	175,8	175,4
Cooling capacity (EN14511) <sup>(3)</sup>	kW	141,2	163,6	187,4	205,1	226,9	257,3	287,4	328,1	368,5
Total input power (EN14511) <sup>(3)</sup>	kW	32,3	37,8	42,2	46,3	52,4	58,8	65,2	74,3	83,4
EER (EN14511) <sup>(3)</sup>	W/W	4,37	4,32	4,44	4,43	4,33	4,37	4,40	4,41	4,41
Free Cooling capacity <sup>(4)</sup>	kW	74,1	93,1	94,0	128,2	129,6	130,9	163,0	164,4	203,0
Power supply	V/Ph/Hz	400/3/50	400/3/50	400/3/50	400/3/50	400/3/50	400/3/50	400/3/50	400/3/50	400/3/50
Peak current	A	320,5	358,5	375,4	333,0	345,0	400,5	417,5	472,4	506,2
Max input current	A	97,0	113,9	130,8	148,0	160,0	177,0	194,0	227,8	261,6
Compressors / Circuits	n°/n°	2/1	2/1	2/1	4/2	4/2	4/2	4/2	4/2	4/2
Capacity steps	n°	2	2	2	4	4	4	4	4	4
Global warming potential (GWP)		2088	2088	2088	2088	2088	2088	2088	2088	2088
Refrigerant charge	kg	15,0	15,0	15,0	20,0	20,0	30,0	30,0	34,0	34,0
Equivalent CO <sub>2</sub> charge	t	31,3	31,3	31,3	41,8	41,8	62,6	62,6	71,0	71,0
Sound power <sup>(5)</sup>	dB(A)	88	88	88	86	88	90	91	91	91
Sound pressure <sup>(6)</sup>	dB(A)	71	71	71	69	71	73	74	74	74

Performances are referred to the following conditions:

(1) Heating: user water temperature 30/35°C, source water temperature 10/7°C.

(2) Average conditions, variable - Reg EU 811/2013

(3) Cooling: user water temperature 12/7°C, source water temperature 30/35°C.

(4) Free Cooling: user water temperature 10°C, source water temperature 20°C, compressors OFF.

(5) Sound power level in accordance with ISO 3744. Operation mode 1, without water pumps.

(6) Sound pressure level at 1 mt from the unit in free field conditions in accordance with ISO 3744. Operation mode 1, without water pumps.



## COMPONENTS

### FRAME

All units are made from hot-galvanised sheet steel, painted with polyurethane powder enamel and stoved at 180°C to provide maximum protection against corrosion. The frame is self-supporting with removable panels. All screws and rivets used are made from stainless steel. The standard colour of the units is RAL 9018.

### REFRIGERANT CIRCUIT

The refrigerant utilised is R410A. The refrigerant circuit is assembled using internationally recognised brand name components with all brazing and welding being performed in accordance with ISO 97/23. Each refrigerant circuit is totally independent from the other with the result that any fault or alarm condition on one circuit does not influence the other.

The refrigerant circuit includes: sight glass, filter drier, thermal expansion valve with external equalizer, Schrader valves for maintenance and control and pressure safety device (for compliance with PED regulations).

### COMPRESSORS

The compressors used are a high performance scroll type that incorporates a special scroll design which enhances the efficiency of the refrigerant cycle when the source temperature is low. The compressors are all supplied with a crankcase heater and thermal overload protection by a klixon embedded in the motor winding. They are mounted in a separate enclosure thus enabling them to be maintained even if the unit is operating. Access to this enclosure is via the front panel of the unit. The crankcase heater is always powered when the compressor is in stand-by.

### SOURCE HEAT EXCHANGER

Source heat exchanger are braze-welded plates and are made of stainless steel AISI 316. From size 039 to size 162 are single-circuit, from size 190 are all double circuit cross-flow. The use of this type of exchangers greatly reduces the refrigerant charge of the unit compared to the conventional shell and tube evaporators, and increases the efficiency of the refrigerant loads. The heat exchangers are factory insulated with flexible close cell material and are protected by a temperature sensor used as antifreeze protection kit.

### USER EXCHANGER

The user side heat exchanger is a braze welded, plate type heat exchanger, manufactured from AISI 316 stainless steel. From size 039 to size 162 they have a single water side circuit, from the size 190 they are double circuit, "cross flow" type. All units are supplied with a sub-cooler to enhance the performance of the refrigerant cycle. The user heat exchangers are factory insulated with flexible close cell material.

### MICROPROCESSORS

All units are supplied as standard with microprocessor controls. The microprocessor controls the following functions: control of the water temperature, antifreeze protection, compressor timing, compressor automatic starting sequence, alarm reset, volt free contact for remote general alarm, alarms and operation LED's. If required (available as an option), the microprocessor can be configured in order for it to connect to a site BMS system thus enabling remote control and management. The technical department can discuss and evaluate, in conjunction with the customer, solutions using MODBUS protocols.

### ELECTRIC ENCLOSURE

The enclosure is manufactured in order to comply with the requirements of the electromagnetic compatibility standards CEE EN60204. Access to the enclosure is achieved by removing the front panel of the unit. The following components are supplied as standard on all units: main switch, thermal overloads (protection of pumps and fans), compressor fuses, control circuit automatic breakers, compressor contactors, fan contactors and pump contactors. The terminal board has volt free contacts for remote ON-OFF, Summer/Winter change over (reversible type only) and general alarm. For all three phase units, a sequence relay that disables the power supply in the event that the phase sequence is incorrect (scroll compressors can be damaged if they rotate in the wrong direction), is fitted as standard.

### CONTROL AND PROTECTION DEVICES

All units are supplied with the following control and protection devices: Return and supply user heat exchanger sensors, return and supply source heat exchanger sensors, high pressure switch with manual reset, low pressure switch with automatic reset, high pressure safety valve, compressor thermal overload protection, pump thermal overload protection (when present), source heat exchanger flow switch.



### HYDRAULIC KIT

all units can be supplied with water pump circulation kit installed on Source, User or Recovery circuit.

## VERSIONS

### WHA/RV 2 Pipe version

This version is capable of cooling during summer operation by using a 4 way reversing valve in the refrigerant circuit.

### WHA/RV/SW6 4 Pipe version

This version has 4 pipes on the user side and is able to produce simultaneously, hot and cold water on 2 independent hydraulic circuits. The domestic hot water production is independent of the operation mode of the unit.

### Versione free cooling

These versions, in addition to the characteristics described above, can produce cold water during summer operation using the cold water available from the source ground probes. All free cooling versions are supplied with an intermediate heat exchanger and a 3 way valve which modulates the water flow to the user circuit depending on the required user cold water temperature. During free cooling mode the compressors may be off or will operate partially to augment the free cooling available.

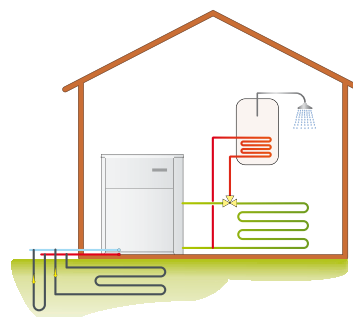

WHA/RV

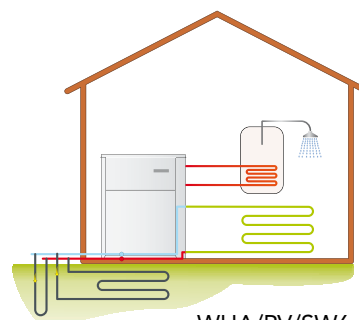

WHA/RV/SW6

## CONFIGURATIONS \*

MOD.	P2	P4	P2+FC	P4+FC	P2+A	P4+A
39	F1	F1	F1	F1	F3	F4
45	F1	F1	F1	F1	F3	F4
50	F1	F1	F1	F1	F3	F4
60	F1	F1	F1	F1	F3	F4
70	F1	F1	F1	F1	F3	F4
80	F1	F1	F1	F1	F3	F4
90	F2	F2	F2	F2	F3	F4
110	F2	F2	F2	F2	F3	F4
120	F2	F2	F2	F2	F3	F4
130	F2	F2	F2	F2	F3	F4
152	F2	F2	F2	F2	F3	F4
162	F2	F2	F2	F2	F3	F4
190	F4	F4	F5	F5	F5	F5
210	F4	F4	F5	F5	F5	F5
240	F4	F4	F5	F5	F5	F5
260	F4	F4	F5	F5	F5	F5
300	F4	F4	F5	F5	F5	F5
320	F4	F4	F5	F5	F5	F5

\* Please contact sales office

### LEGEND

<b>P2</b>	2 pipe system	<b>P4</b>	4 pipe system with Free Cooling
<b>P4</b>	4 pipe system	<b>P2+A</b>	2 pipe system with hydraulic kit
<b>P2+FC</b>	2 pipe system with Free Cooling	<b>P4+A</b>	4 pipe system with hydraulic kit

# ACCESSORIES

WHA		039÷080	090÷110	120÷162	190÷260	300÷320
Main switch		●	●	●	●	●
Microprocessor control		●	●	●	●	●
Remote ON/OFF digital input		●	●	●	●	●
Summer/Winter digital input		●	●	●	●	●
LS low noise version [-4dB(A) of STD]	LS00	○	○	○	○	○
Electronic Soft starter	DSSE	○	○	○	○	○
Rubber anti-vibration mountings	KAVG	○	○	○	○	○
Spring anti-vibration mountings	KAVM	○	○	○	○	○
Refrigerant circuit pressure gauges	MAML	○	○	○	○	○
Liquid line solenoid valve	VSLI	○	○	○	○	○
Remote control panel	PCRL	○	○	○	○	○
Serial interface card RS485 with MODBUS protocol	INSE	●	●	●	●	●
2 way modulating to control source water consumption	V2M0	○	○	○	○	○
Electronic thermostatic valve	VTEE	○	○	○	○	○
Hydraulic kit with one pump without tank - user circuit	A1NTU	○	○	○	○	○
Hydraulic kit with one pump without tank - source circuit	A1NTS	○	○	○	○	○
Hydraulic kit with one pump without tank - recovery circuit	A1NTR	○	○	○	○	○
Hydraulic kit with two pumps without tank - user circuit	A2NTU	○	○	○	○	○
Hydraulic kit with two pumps without tank - source circuit	A2NTS	○	○	○	○	○
Hydraulic kit with two pumps without tank - recovery circuit	A2NTR	○	○	○	○	○

● Standard, ○ Optional, – Not available.

## OPERATION LIMITS

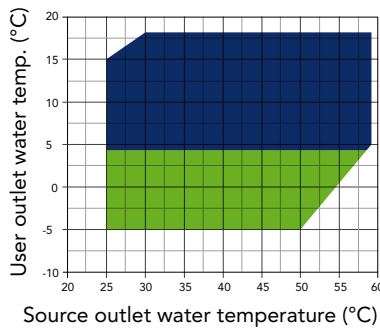
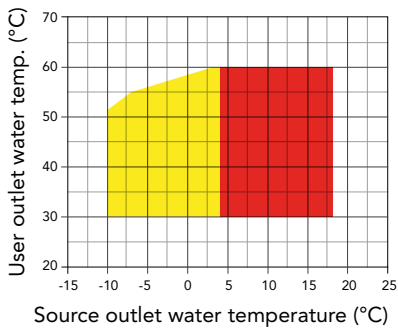

- Heating
  - Heating with glycol source circuit
  - Cooling
  - Cooling with glycol user circuit
- Operating limits with 5°C Δt

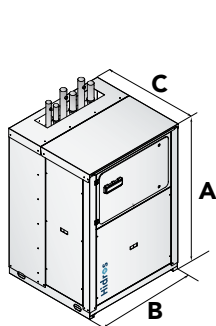

Frame 1

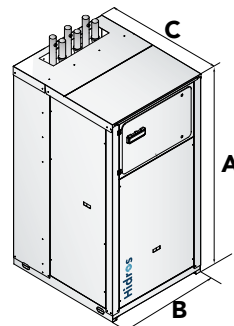

Frame 2

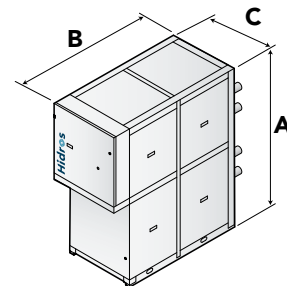

Frame 3

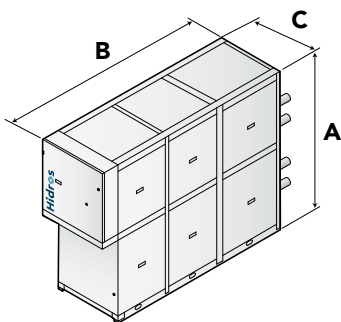

Frame 4

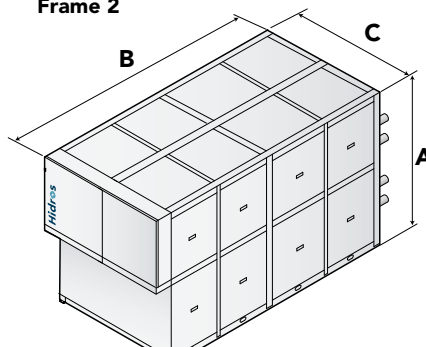

Frame 5

Mod.	A (mm)	B (mm)	C (mm)
F1	1566	1101	1005
F2	1986	1101	1255
F3	1900	2170	800
F4	1900	3120	800
F5	1730	3030	1600

Heating capacity from 39 kW to 302 kW

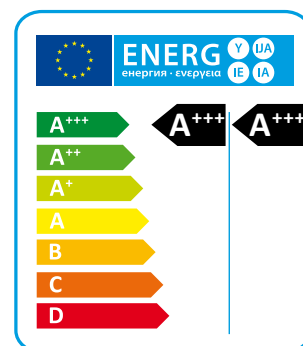

WHK heat pumps are particularly suitable for applications that use source energy at medium or high temperatures. These units have been designed to produce water at high or very high temperature for applications where it is necessary to have maximum efficiency in heating. The units are available in heating only mode and can produce water up to 78°C (HT version). A wide range of accessories allows you to choose the optimal solution.

### VERSIONS

- HH** Standard, heating only.
- LT** Low source/user temperature.
- HT** High source/user temperature.
- LS** Low noise.
- XL** Super low noise.
- P2U** 2 pipe systems without domestic hot water production.

## TECHNICAL DATA

WHK LT/XL/HH - P2U		312	412	612	712	912	1212	1412	1804	2304	2604
Heating capacity (EN14511) <sup>(1)</sup>	kW	38,8	46,0	58,4	70,3	88,4	109,9	136,5	176,9	219,5	273,2
Input power (EN14511) <sup>(1)</sup>	kW	8,2	9,4	11,8	14,8	18,8	23,1	27,9	37,2	45,7	55,3
COP (EN14511) <sup>(1)</sup>	W/W	4,73	4,85	4,93	4,76	4,70	4,75	4,88	4,75	4,80	4,94
Energy Class in low temperature <sup>(2)</sup>		A+++	A+++	A+++	A+++	A+++	A+++	A+++	A+++	A+++	A+++
SCOP low temperature <sup>(2)</sup>	kWh/kWh	4,85	5,00	5,16	5,00	5,08	5,17	5,36	5,29	5,38	5,56
η <sub>s,h</sub> low temperature <sup>(2)</sup>	%	185,9	192,1	198,2	191,8	195,3	198,9	206,3	203,4	207,0	214,4
Energy Class in medium temperature <sup>(2)</sup>		A++	A++	A++	A++	A++	A++	A++	A++	A++	A++
SCOP medium temperature <sup>(2)</sup>	kWh/kWh	4,07	4,19	4,28	4,18	4,16	4,22	4,35	4,27	4,34	4,47
η <sub>s,h</sub> medium temperature <sup>(2)</sup>	%	154,8	159,6	163,0	159,0	158,3	160,9	165,9	162,8	165,6	170,7
Power supply	V/Ph/Hz	400/3/50	400/3/50	400/3/50	400/3/50	400/3/50	400/3/50	400/3/50	400/3/50	400/3/50	400/3/50
Maximum input current	A	128,7	137,6	168,0	209,0	266,0	324,0	372,5	348,0	428,0	497,5
Peak current	A	35,4	39,2	56,0	70,0	82,0	104,0	125,0	164,0	208,0	250,0
Compressors / Circuits	n°/n°	2/1	2/1	2/1	2/1	2/1	2/1	2/1	4/2	4/2	4/2
Capacity steps	n°	2	2	2	2	2	2	2	4	4	4
Refrigerant		R134a	R134a	R134a	R134a	R134a	R134a	R134a	R134a	R134a	R134a
Global warming potential (GWP)		1430	1430	1430	1430	1430	1430	1430	1430	1430	1430
Refrigerant charge	kg	2,0	2,0	3,0	3,0	4,0	5,0	6,0	8,5	10,5	13,0
Equivalent CO <sub>2</sub> charge	t	2,9	2,9	4,3	4,3	5,7	7,2	8,6	12,2	15,0	18,6
Sound power LS version <sup>(3)</sup>	dB(A)	--	--	--	--	--	--	--	88	89	91
Sound pressure LS version <sup>(4)</sup>	dB(A)	--	--	--	--	--	--	--	72	73	75
Sound power XL version <sup>(3)</sup>	dB(A)	65	65	70	73	74	76	78	--	--	--
Sound pressure XL version <sup>(4)</sup>	dB(A)	49	49	54	57	58	60	62	--	--	--

WHK HT/XL/HH - P2U		312	412	612	712	912	1212	1412	1804	2304	2604
Heating capacity (EN14511) <sup>(1)</sup>	kW	37,6	43,6	64,1	75,1	97,8	121,7	150,5	195,6	243,9	301,2
Input power (EN14511) <sup>(1)</sup>	kW	6,7	7,5	11,1	13,7	17,6	21,7	26,2	35,0	43,1	52,2
COP (EN14511) <sup>(1)</sup>	W/W	5,65	5,83	5,79	5,48	5,56	5,62	5,74	5,59	5,65	5,77
Energy Class in low temperature <sup>(2)</sup>		A+++	A+++	A+++	A+++	A+++	A+++	A+++	A+++	A+++	A+++
SCOP low temperature <sup>(2)</sup>	kWh/kWh	5,71	5,83	5,91	5,81	5,85	5,94	6,09	5,95	6,01	6,20
η <sub>s,h</sub> low temperature <sup>(2)</sup>	%	220,2	225,3	228,2	224,5	226,0	229,4	235,6	230,0	232,4	239,9
Energy Class in medium temperature <sup>(2)</sup>		A++	A++	A++	A++	A++	A++	A++	A++	A++	A++
SCOP medium temperature <sup>(2)</sup>	kWh/kWh	4,62	4,73	4,78	4,76	4,67	4,74	4,85	4,73	4,79	4,91
η <sub>s,h</sub> medium temperature <sup>(2)</sup>	%	176,9	182,1	183,2	182,2	178,7	181,5	186,1	181,0	183,6	188,3
Power supply	V/Ph/Hz	400/3/50	400/3/50	400/3/50	400/3/50	400/3/50	400/3/50	400/3/50	400/3/50	400/3/50	400/3/50
Maximum input current	A	111,4	128,7	167,1	208,3	267,9	324,8	372,9	353,7	430,4	498,7
Peak current	A	32,8	35,4	54,2	68,6	85,8	105,6	125,8	171,6	211,2	251,6
Compressors / Circuits	n°/n°	2/1	2/1	2/1	2/1	2/1	2/1	2/1	4/2	4/2	4/2
Capacity steps	n°	2	2	2	2	2	2	2	4	4	4
Refrigerant		R134a	R134a	R134a	R134a	R134a	R134a	R134a	R134a	R134a	R134a
Global warming potential (GWP)		1430	1430	1430	1430	1430	1430	1430	1430	1430	1430
Refrigerant charge	kg	4,0	4,0	5,0	6,0	8,0	10,0	10,0	21,0	26,0	33,0
Equivalent CO <sub>2</sub> charge	t	5,7	5,7	7,2	8,6	11,4	14,3	14,3	30,0	37,2	47,2
Sound power LS version <sup>(3)</sup>	dB(A)	--	--	--	--	--	--	--	88	89	91
Sound pressure LS version <sup>(4)</sup>	dB(A)	--	--	--	--	--	--	--	72	73	75
Sound power XL version <sup>(3)</sup>	dB(A)	65	65	70	73	74	76	78	--	--	--
Sound pressure XL version <sup>(4)</sup>	dB(A)	49	49	54	57	58	60	62	--	--	--

Performances are referred to the following conditions:

(1) Heating: user water temperature 30/35°C, source water temperature 10/7°C.

(2) Average conditions, variable - Reg EU 811/2013

(3) Sound power level in accordance with ISO 3744.

(4) Sound pressure level at 1 mt from the unit in free field conditions in accordance with ISO 3744.

## COMPONENTS

### FRAME

All units are made from hot-galvanised sheet steel, painted with polyurethane powder enamel and stoved at 180°C to provide maximum protection against corrosion. The frame is self-supporting with removable panels. All screws and rivets used are made from stainless steel. The standard colour of the units is RAL 9018.

### REFRIGERANT CIRCUIT

The refrigerant utilised is R134a. The refrigerant circuit is assembled using internationally recognised brand name components with all brazing and welding being performed in accordance with ISO 97/23. Each refrigerant circuit is totally independent from the other with the result that any fault or alarm condition on one circuit does not influence the other. The refrigerant circuit includes: sight glass, filter drier, thermal expansion valve with external equalizer, Schrader valves for maintenance and control and pressure safety device (for compliance with PED regulations).

### COMPRESSORS

The compressors used are a high performance scroll type that incorporates a special scroll design which enhances the efficiency of the refrigerant cycle when the source temperature is low. The compressors are all supplied with a crankcase heater and thermal overload protection by a klixon embedded in the motor winding. They are mounted in a separate enclosure thus enabling them to be maintained even if the unit is operating. Access to this enclosure is via the front panel of the unit. The crankcase heater is always powered when the compressor is in stand-by.

### SOURCE HEAT EXCHANGER

Source heat exchanger are braze-welded plates and are made of stainless steel AISI 316. The use of this type of exchangers greatly reduces the refrigerant charge of the unit compared to the conventional shell and tube evaporators, and increases the efficiency of the refrigerant loads. The heat exchangers are factory insulated with flexible close cell material and are protected by a temperature sensor used as antifreeze protection kit.

### USER EXCHANGER

The user side heat exchanger is a braze welded, plate type heat exchanger, manufactured from AISI 316 stainless steel. All units are supplied with a sub-cooler to enhance the performance of the refrigerant cycle. The user heat exchangers are factory insulated with flexible close cell material.

### MICROPROCESSORS

All units are supplied as standard with microprocessor controls. The microprocessor controls the following functions: control of the water temperature, antifreeze protection, compressor timing, compressor automatic starting sequence, alarm reset, volt free contact for remote general alarm, alarms and operation LED's. If required (available as an option), the microprocessor can be configured in order for it to connect to a site BMS system thus enabling remote control and management. The technical department can discuss and evaluate, in conjunction with the customer, solutions using MODBUS protocols.

### ELECTRIC ENCLOSURE

The enclosure is manufactured in order to comply with the requirements of the electromagnetic compatibility standards CEE EN60204. Access to the enclosure is achieved by removing the front panel of the unit. The following components are supplied as standard on all units: main switch, thermal overloads (protection of pumps and fans), compressor fuses, control circuit automatic breakers, compressor contactors, fan

contactors and pump contactors. The terminal board has volt free contacts for remote ON-OFF, Summer/Winter change over (reversible type only) and general alarm. For all three phase units, a sequence relay that disables the power supply in the event that the phase sequence is incorrect (scroll compressors can be damaged if they rotate in the wrong direction), is fitted as standard.

### CONTROL AND PROTECTION DEVICES

All units are supplied with the following control and protection devices: Return and supply user heat exchanger sensors, return and supply source heat exchanger sensors, high pressure switch with manual reset, low pressure switch with automatic reset, high pressure safety valve, compressor thermal overload protection, pump thermal overload protection (when present), source heat exchanger flow switch.

## VERSIONS

### WHK/HH

These units have been designed to produce water at high or very high temperature by using a source water temperature of 12°C with possibility to produce hot water up to 70°C or more.

### WHK/HH/HT

This version is equipped with special compressors that allow the cooling circuit to manage high source water temperature, up to 45°C, with the consequent possibility of producing very high water temperatures on the user side up to 78°C.

### WHK/HH/LT

This version is equipped with special compressors that allow the cooling circuit to manage medium source water temperature, up to 20°C, with the consequent possibility of producing very high water temperatures on the user side up to 70°C.

### Version LS

This version includes the complete acoustic insulation of the unit with compressor jackets and insulating material made with high density media and the interposition of heavy bitumen layer.

### Super low noise version XL

All units in XL versions are supplied, as standard, with the latest 'Floating Frame' technology that completely isolates the compressors from the main casing, thereby eliminating vibration and noise from this source. The 'Floating Frame' is a special vibration and acoustic damping system that consists of a base plate and acoustic enclosure that houses the compressors. The base plate is separated from the supporting frame of the unit by soft steel springs that have a high damping power. Within the enclosure, the compressors are mounted on rubber shock absorbers on the floating base plate. The enclosure is manufactured from galvanized steel sandwich panels that have a micro-perforated inner skin and a core of 30 mm thick, high density (25 kg/m<sup>3</sup>). The entire arrangement provides a double damping system and acoustic attenuation. The compressor refrigerant pipes are connected to the refrigerant circuit through "anaconda" flexible connections. Flexible connections are also used on the water pipework within the unit. The combination of these systems results in an overall noise reduction in the region of 6-8 dB(A).

## ACCESSORIES

WHK		312	412	612	712	912	1212	1412	1804	2304	2604
XL Super low noise version	XL00	●	●	●	●	●	●	●	-	-	-
LS low noise version [-4dB(A) of STD]	LS00	-	-	-	-	-	-	-	●	●	●
Electronic Soft starter	DSSE	○	○	○	○	○	○	○	○	○	○
Rubber anti-vibration mountings	KAVG	○	○	○	○	○	○	○	○	○	○
Spring anti-vibration mountings	KAVM	○	○	○	○	○	○	○	○	○	○
Refrigerant circuit pressure gauges	MAML	○	○	○	○	○	○	○	○	○	○
Liquid line solenoid valve	VSLI	-	-	-	-	-	-	-	-	-	-
Remote control panel	PCRL	○	○	○	○	○	○	○	○	○	○
Serial interface card RS485 with MODBUS protocol	INSE	●	●	●	●	●	●	●	●	●	●
2 way modulating valve - source	V2M0	○	○	○	○	○	○	○	○	○	○
Electronic thermostatic valve	VTEE	●	●	●	●	●	●	●	●	●	●

● Standard, ○ Optional, - Not available.

## OPERATION LIMITS

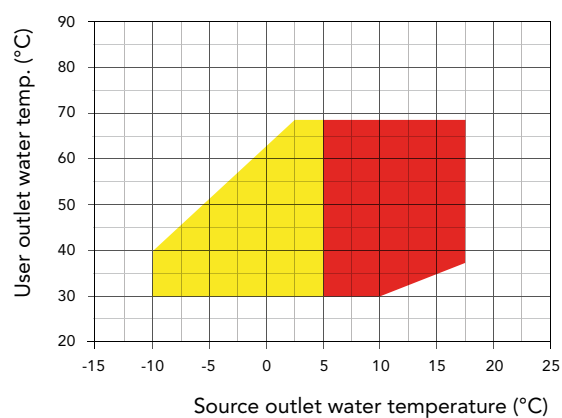
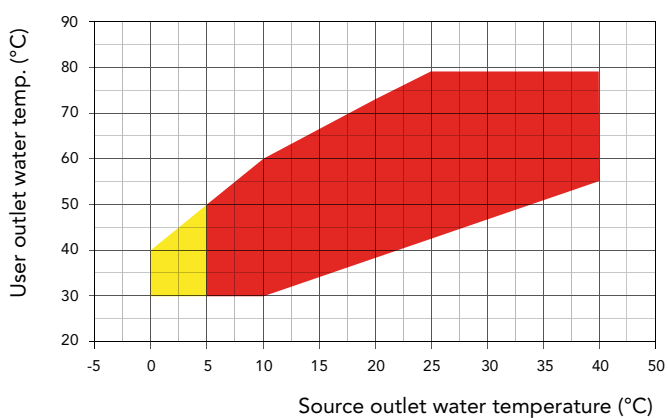

■ Standard version  
■ Standard version with glycol

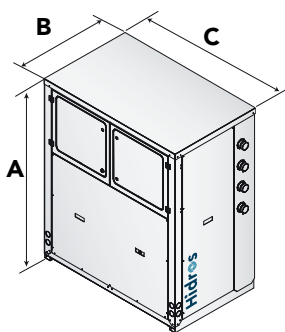

Mod.	A (mm)	B (mm)	C (mm)	kg
312	1631	790	1145	510
412	1656	790	1145	730
612	1656	790	1145	750
712	1656	790	1145	780
912	1656	790	1145	790
1212	1656	790	1145	810
1412 (LT)	1656	790	1145	840

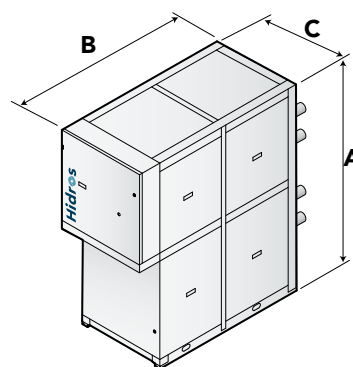

Mod.	A (mm)	B (mm)	C (mm)	kg
1412 (HT)	1900	2177	794	1450
1804	1900	3127	794	1370
2304	1900	3127	794	1440
2604	1900	3127	794	1480

# LHi/P4

## 4 PIPE SYSTEMS HIGH EFFICIENCY AIR TO WATER HEAT PUMPS WITH INVERTER COMPRESSOR

Heating capacity from 54 kW to 271 kW

R410A

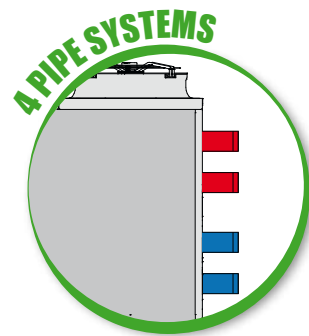
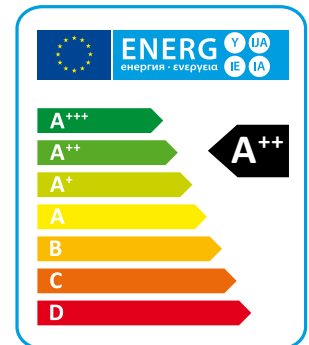

The LHi P4U/P4S series high-efficiency air-to-water heat pumps are units designed for four-pipe air conditioning and heating systems, which allow the simultaneous or separate production of cold water for cooling and hot water for heating. The units are supplied with an additional exchanger, used as a condenser for hot water, whose production is independent of the unit's operating mode. The exchanger is automatically activated by microprocessor control when the hot water temperature on the return flow is lower than the set applied. These units are able to produce hot water and cold water simultaneously and/or separately with very high energy efficiency.

They are all supplied complete with a specific advanced microprocessor control equipped with software for the management of the various priorities.

The XL versions also have an extremely low noise level thanks to the use of a special floating vibration dampening system that allows a noise reduction of about 6-8 dB(A) (optional).

### VERSIONS

- RV** Reversible heating/cooling.
- SE** Standard efficiency, EC fans.
- LS** Low noise.
- XL** Super low noise.
- P4U** 4 pipe systems heating/cooling.
- P4S** 2+2 pipe systems with D.H.W. production.



## TECHNICAL DATA

SE/LS/RV - P4S		532	632	742	862	912	1052	1222	1534	1654	1854	1964	2254	2554
Heating capacity (EN14511) <sup>(1)</sup>	kW	53,3	61,8	74,2	85,1	90,9	102,5	118,3	129,0	145,3	165,2	188,7	223,4	269,6
Total input power (EN14511) <sup>(1)</sup>	kW	13,2	14,7	18,7	20,0	22,1	24,9	28,5	31,2	34,0	39,1	44,8	55,1	65,8
COP (EN14511) <sup>(1)</sup>	W/W	4,04	4,19	3,97	4,25	4,11	4,12	4,15	4,14	4,27	4,23	4,21	4,06	4,10
Energy Class <sup>(2)</sup>		A++	A++	A++	A++	A++	A++	A++	A++	A++	A++	A++	A++	A++
SCOP <sup>(2)</sup>	kWh/kWh	3,88	3,93	3,90	3,98	3,92	3,93	3,88	3,95	3,93	4,00	3,90	3,88	3,88
η <sub>s,h</sub> <sup>(2)</sup>	%	152	154	153	156	154	154	152	155	154	157	153	152	152
Cooling capacity (EN14511) <sup>(3)</sup>	kW	49,32	57,71	68,9	78,87	83,19	95,32	109,3	112,8	129,4	146,3	162,5	197,4	230,6
Total input power (EN14511) <sup>(3)</sup>	kW	16,42	18,47	24,48	25,78	28,18	31,81	36,3	40,3	42,6	50,2	57,0	69,5	84,6
EER (EN14511) <sup>(3)</sup>	W/W	3,00	3,12	2,81	3,06	2,95	3,00	3,01	2,80	3,04	2,91	2,85	2,84	2,72
TER (EN 14511) <sup>(4)</sup>		10,00	10,27	9,72	10,12	9,84	9,98	10,08	10,32	10,45	10,43	9,99	9,94	9,78
Sound power level <sup>(5)</sup>	dB (A)	81	81	83	83	83	84	85	86	87	87	87	89	89
Sound pressure level <sup>(6)</sup>	dB (A)	49	49	51	51	51	52	53	54	55	55	55	57	57
Power supply	V/Ph/Hz	400/3/50	400/3/50	400/3/50	400/3/50	400/3/50	400/3/50	400/3/50	400/3/50	400/3/50	400/3/50	400/3/50	400/3/50	400/3/50
Compressors / Circuits	n° / n°	2 / 1	2 / 1	2 / 1	2 / 1	2 / 1	2 / 1	2 / 1	4 / 2	4 / 2	4 / 2	4 / 2	4 / 2	4 / 2
Fans	n°	2	2	2	3	3	3	4	2	3	3	3	4	4
Refrigerant		R410A	R410A	R410A	R410A	R410A	R410A	R410A	R410A	R410A	R410A	R410A	R410A	R410A
Refrigerant charge	kg	10,4	14,7	14,7	17,5	17,5	22,3	22,7	32,6	39,8	39,8	45,5	50,9	59,0
Global warming potential (GWP)		2088	2088	2088	2088	2088	2088	2088	2088	2088	2088	2088	2088	2088
Equivalent CO <sub>2</sub> charge	t	21,8	30,7	30,7	36,5	36,5	46,5	47,4	68,0	83,2	83,2	95,0	106,2	123,1
Water tank volume	l	140	300	300	500	500	500	500	300	500	500	500	500	500

SE/LS/RV - P4U		532	632	742	862	912	1052	1222	1534	1654	1854	1964	2254	2554
Heating capacity (EN14511) <sup>(1)</sup>	kW	53,2	61,8	74,5	86,4	90,9	102,4	118,3	129,5	146,2	166,9	189,9	224,4	270,6
Total input power (EN14511) <sup>(1)</sup>	kW	12,8	14,3	18,2	19,8	21,5	24,3	27,9	30,3	33,0	38,1	43,4	53,4	63,4
COP (EN14511) <sup>(1)</sup>	W/W	4,17	4,31	4,09	4,36	4,22	4,22	4,24	4,28	4,43	4,38	4,38	4,20	4,27
Energy Class <sup>(2)</sup>		A++	A++	A++	A++	A++	A++	A++	A++	A++	A++	A++	A++	A++
SCOP <sup>(2)</sup>	kWh/kWh	3,93	3,98	4,00	4,05	3,98	3,95	3,85	4,05	4,00	4,05	3,98	3,93	3,90
η <sub>s,h</sub> <sup>(2)</sup>	%	154	156	157	159	156	155	151	159	157	159	156	154	153
Cooling capacity (EN14511) <sup>(3)</sup>	kW	56,6	66,0	81,1	91,0	96,5	110,9	126,9	133,0	147,2	171,7	188,5	228,7	271,8
Total input power (EN14511) <sup>(3)</sup>	kW	12,6	14,2	18,6	19,9	21,8	24,7	27,9	28,5	31,2	36,4	41,9	51,1	61,9
EER (EN14511) <sup>(3)</sup>	W/W	4,51	4,64	4,37	4,57	4,43	4,50	4,55	4,66	4,73	4,72	4,50	4,47	4,39
TER (EN 14511) <sup>(4)</sup>		10,00	10,27	9,72	10,12	9,84	9,98	10,08	10,32	10,45	10,43	9,99	9,94	9,78
Sound power level <sup>(5)</sup>	dB (A)	81	81	83	83	83	84	85	86	87	87	87	89	89
Sound pressure level <sup>(6)</sup>	dB (A)	49	49	51	51	51	52	53	54	55	55	55	57	57
Power supply	V/Ph/Hz	400/3/50	400/3/50	400/3/50	400/3/50	400/3/50	400/3/50	400/3/50	400/3/50	400/3/50	400/3/50	400/3/50	400/3/50	400/3/50
Compressors / Circuits	n° / n°	2 / 1	2 / 1	2 / 1	2 / 1	2 / 1	2 / 1	2 / 1	4 / 2	4 / 2	4 / 2	4 / 2	4 / 2	4 / 2
Fans	n°	2	2	2	3	3	3	4	2	3	3	3	4	4
Refrigerant		R410A	R410A	R410A	R410A	R410A	R410A	R410A	R410A	R410A	R410A	R410A	R410A	R410A
Refrigerant charge	kg	10,4	14,7	14,7	17,5	17,5	22,3	22,7	32,6	39,8	39,8	45,5	50,9	59,0
Global warming potential (GWP)		2088	2088	2088	2088	2088	2088	2088	2088	2088	2088	2088	2088	2088
Equivalent CO <sub>2</sub> charge	t	21,8	30,7	30,7	36,5	36,5	46,5	47,4	68,0	83,2	83,2	95,0	106,2	123,1
Water tank volume	l	140	300	300	500	500	500	500	300	500	500	500	500	500

Performances are referred to the following conditions:

- (1) Heating: Ambient temperature 7°C DB, 6°C WB, water temperature 30/35°C.
- (2) Average conditions, low temperature, variable - Reg EU 811/2013.
- (3) Cooling: ambient air temperature 35°C, evaporator water temperature in/out 12/7 °C.

(4) TER: Total Energy Ratio-cold circuit 12/7°C, hot circuit 30/35°C

(5) Sound power level in accordance with ISO 3744.

(6) Sound pressure level at 10 mt from the unit in free field conditions in accordance with ISO 3744.

SE/XL/RV - P4S		532	632	742	862	912	1052	1222	1534	1654	1854	1964	2254	2554
Heating capacity (EN14511) <sup>(1)</sup>	kW	51,8	59,4	77,1	82,9	87,8	101,9	114,4	126,9	142,2	163,6	184,6	224,7	267,2
Total input power (EN14511) <sup>(1)</sup>	kW	12,8	14,3	18,6	19,8	21,5	24,2	27,7	30,1	32,3	37,7	42,9	53,3	63,8
COP (EN14511) <sup>(1)</sup>	W/W	4,04	4,15	4,15	4,20	4,08	4,21	4,13	4,22	4,41	4,35	4,31	4,22	4,19
Energy Class <sup>(2)</sup>		A++	A++	A++	A++	A++	A++	A++	A++	A++	A++	A++	A++	A++
SCOP <sup>(2)</sup>	kWh/kWh	3,95	4,10	4,08	4,13	4,10	4,03	4,00	4,18	4,28	4,25	4,18	4,15	4,13
$\eta_{s,h}$ <sup>(2)</sup>	%	155	161	160	162	161	158	157	164	168	167	164	163	162
Cooling capacity (EN14511) <sup>(3)</sup>	kW	48,0	55,9	70,4	76,4	80,4	91,9	105,7	109,4	124,9	140,1	154,6	198,5	231,8
Total input power (EN14511) <sup>(3)</sup>	kW	16,3	18,4	22,7	25,6	28,1	32,1	36,2	38,9	40,8	49,4	56,0	62,9	77,9
EER (EN14511) <sup>(3)</sup>	W/W	2,86	2,96	3,00	2,90	2,79	2,80	2,84	2,68	2,93	2,73	2,67	2,97	2,83
TER (EN 14511) <sup>(4)</sup>		10,00	10,27	9,72	10,12	9,84	9,98	10,08	10,32	10,45	10,43	9,99	9,94	9,78
Sound power level <sup>(5)</sup>	dB (A)	76	77	78	78	79	79	80	80	80	80	82	83	84
Sound pressure level <sup>(6)</sup>	dB (A)	44	45	46	46	47	47	48	48	48	48	50	51	52
Power supply	V/Ph/Hz	400/3/50	400/3/50	400/3/50	400/3/50	400/3/50	400/3/50	400/3/50	400/3/50	400/3/50	400/3/50	400/3/50	400/3/50	400/3/50
Compressors / Circuits	n° / n°	2 / 1	2 / 1	2 / 1	2 / 1	2 / 1	2 / 1	2 / 1	4 / 2	4 / 2	4 / 2	4 / 2	4 / 2	4 / 2
Fans	n°	2	2	2	3	3	3	4	2	3	3	3	4	4
Refrigerant		R410A	R410A	R410A	R410A	R410A	R410A	R410A	R410A	R410A	R410A	R410A	R410A	R410A
Refrigerant charge	kg	10,4	14,7	16,3	17,5	17,5	22,3	22,7	32,6	39,8	39,8	32,5	50,9	59,0
Global warming potential (GWP)		2088	2088	2088	2088	2088	2088	2088	2088	2088	2088	2088	2088	2088
Equivalent CO <sub>2</sub> charge	t	21,8	30,7	34,1	36,5	36,5	46,5	47,4	68,0	83,2	83,2	67,8	106,2	123,1
Water tank volume	l	140	300	300	500	500	500	500	300	500	500	500	500	500

SE/XL/RV - P4U		532	632	742	862	912	1052	1222	1534	1654	1854	1964	2254	2554
Heating capacity (EN14511) <sup>(1)</sup>	kW	51,2	59,3	77,1	82,8	87,5	97,8	114,0	127,3	143,9	162,5	184,9	217,3	264,7
Total input power (EN14511) <sup>(1)</sup>	kW	12,4	13,9	18,0	19,3	20,9	23,6	27,1	29,2	31,6	36,4	41,5	50,6	61,8
COP (EN14511) <sup>(1)</sup>	W/W	4,14	4,25	4,29	4,30	4,18	4,14	4,21	4,36	4,56	4,46	4,46	4,29	4,29
Energy Class <sup>(2)</sup>		A++	A++	A++	A++	A++	A++	A++	A++	A++	A++	A++	A++	A++
SCOP <sup>(2)</sup>	kWh/kWh	3,98	4,15	4,15	4,18	4,13	4,08	4,03	4,28	4,38	4,38	4,33	4,20	4,15
$\eta_{s,h}$ <sup>(2)</sup>	%	156	163	163	164	162	160	158	168	172	172	170	165	163
Cooling capacity (EN14511) <sup>(3)</sup>	kW	48,0	55,9	70,4	76,4	80,4	91,9	105,7	109,4	124,9	140,1	154,6	198,5	231,8
Total input power (EN14511) <sup>(3)</sup>	kW	16,3	18,4	22,7	25,6	28,1	32,1	36,2	38,9	40,8	49,4	56,0	62,9	77,9
EER (EN14511) <sup>(3)</sup>	W/W	2,86	2,96	3,00	2,90	2,79	2,80	2,84	2,68	2,93	2,73	2,67	2,97	2,83
TER (EN 14511) <sup>(4)</sup>		10,00	10,27	9,72	10,12	9,84	9,98	10,08	10,32	10,45	10,43	9,99	9,94	9,78
Sound power level <sup>(5)</sup>	dB (A)	76	77	78	78	79	79	80	80	80	80	82	83	84
Sound pressure level <sup>(6)</sup>	dB (A)	44	45	46	46	47	47	48	48	48	48	50	51	52
Power supply	V/Ph/Hz	400/3/50	400/3/50	400/3/50	400/3/50	400/3/50	400/3/50	400/3/50	400/3/50	400/3/50	400/3/50	400/3/50	400/3/50	400/3/50
Compressors / Circuits	n° / n°	2 / 1	2 / 1	2 / 1	2 / 1	2 / 1	2 / 1	2 / 1	4 / 2	4 / 2	4 / 2	4 / 2	4 / 2	4 / 2
Fans	n°	2	2	2	3	3	3	4	2	3	3	3	4	4
Refrigerant		R410A	R410A	R410A	R410A	R410A	R410A	R410A	R410A	R410A	R410A	R410A	R410A	R410A
Refrigerant charge	kg	10,4	14,7	16,3	17,5	17,5	22,3	22,7	32,6	39,8	39,8	32,5	50,9	59,0
Global warming potential (GWP)		2088	2088	2088	2088	2088	2088	2088	2088	2088	2088	2088	2088	2088
Equivalent CO <sub>2</sub> charge	t	21,8	30,7	34,1	36,5	36,5	46,5	47,4	68,0	83,2	83,2	67,8	106,2	123,1
Water tank volume	l	140	300	300	500	500	500	500	300	500	500	500	500	500

Performances are referred to the following conditions:

- (1) Heating: Ambient temperature 7°C DB, 6°C WB, water temperature 30/35°C.  
(2) Average conditions, low temperature, variable - Reg EU 811/2013.  
(3) Cooling: ambient air temperature 35°C, evaporator water temperature in/out 12/7 °C.

- (4)TER: Total Energy Ratio-cold circuit 12/7°C, hot circuit 30/35°C  
(5) Sound power level in accordance with ISO 3744.  
(6) Sound pressure level at 10 mt from the unit in free field conditions in accordance with ISO 3744.

## COMPONENTS

### FRAME

All units are made from hot-galvanised sheet steel, painted with polyurethane powder enamel and stoved at 180°C to provide maximum protection against corrosion. The frame is self-supporting with removable panels. All screws and rivets used are made from stainless steel. The standard colour of the units is RAL9018.

### REFRIGERANT CIRCUIT

The refrigerant utilised is R410A. The refrigerant circuit is assembled using internationally recognised brand name components with all brazing and welding being performed in accordance with ISO 97/23. The refrigerant circuit includes: sight glass, filter drier, two thermal expansion valves (one for cooling mode, one for heating mode) with external equalizer, 4 way reversing valve, check valves, liquid receiver, Schrader valves for maintenance and control, pressure safety device (for compliance with PED regulations).

### COMPRESSORS

The compressors used are three-phase scroll type BPM (brushless permanent magnet) high efficiency, controlled by an Inverter, supplied with a specific design that increases the efficiency of the refrigerant cycle in very low ambient temperature conditions. All sizes use compressors in tandem configuration, and are all optimized for heat pump applications for high seasonal efficiency (SCOP).

The compressors are all supplied with electrical resistance and thermal overload protection. They are all mounted in a dedicated compartment to keep them separated from the airflow. The electric heater is always powered when the compressor is in stand by mode. Maintenance is possible through the front panel of the unit which allows to reach the compressors even when the machine is running.

### SOURCE HEAT EXCHANGER

The source heat exchanger is made from copper pipes and aluminium fins. Dimensioning of the copper pipes and the aluminium wings is optimized in order to obtain excellent performance.

The tubes are mechanically expanded into the fins in order to maximise heat transfer. Furthermore, the design guarantees a low air side pressure drop thus enabling the use of low rotation speed (and hence low noise) fans. All heat exchangers are supplied standard with fins hydrophilic coating.

### USER HEAT EXCHANGERS (P4U/P4S versions)

The user heat exchanger is a braze welded, plate type heat exchanger, manufactured from AISI 316 stainless steel. The use of this type of exchanger results in a massive reduction of the refrigerant charge of the unit compared to a traditional shell-in-tube type. A further advantage is a reduction in the overall dimensions of the unit.

The exchangers are factory insulated with flexible close cell material and can be fitted with an antifreeze heater (accessory). Each exchanger is fitted with a temperature sensor on the discharge water side for antifreeze protection.

### HIGH EFFICIENCY E.C. AXIAL FANS (VECE)

High efficiency E.C. axial fans, supplied with Brushless DC electric motors electronically commutated (E.C. motors) able to grants the highest energy efficiency class according to the latest EU specifications, with the result of substantial energy consumption reduction for ventilation. The fans are statically and dynamically balanced and supplied complete with a safety fan guard complying with the requirements of EN 60335. The fans are installed using a special steel profiled beam who minimize all vibrations. All units are fitted with a pressure transducer for the control of the evaporation/condensation pressure. All electric motors are The motors are fitted with integrated thermal overload protection rating IP54.

### MICROPROCESSORS

All units are supplied as standard complete with control panel. The microprocessor controls the following functions: control of the water temperature, antifreeze protection, compressor timing, compressor automatic starting sequence (For multiple compressors), alarm reset.

The control panel is supplied with display showing all operational icons. The microprocessor is set for automatic defrost (when operating in severe ambient conditions) and for summer/ winter change over (only for RV versions).

The control also manages the anti-legionella program, the integration with other heating sources (electric heaters, boilers, solar panels etc), the operation of a three port modulating valve (for diverting to DHW or heating) and both the heating circuit pump and the domestic hot water circuit pump. If required (available as an option), the microprocessor can be configured in order for it to connect to a site BMS system thus enabling remote control and management.

### ELECTRIC ENCLOSURE

The enclosure is manufactured in order to comply with the requirements of the electromagnetic compatibility standards CEE EN60204. Access to electrical cabinet in quick and easy thanks to hinged panels. The following components are supplied as standard on all units: main switch, a sequence relay that disables the power supply in the event that the phase sequence is incorrect (scroll compressors can be damaged if they rotate in the wrong direction), thermal overloads (protection of pumps and fans), compressor fuses, control circuit automatic breakers, compressor contactors, fan contactors and pump contactors. The terminal board has volt free contacts for remote ON-OFF, Summer/ winter change over (heat pumps only) and general alarm.

### CONTROL AND PROTECTION DEVICES

All units are supplied with the following controls and protections: user water return temperature sensor, antifreeze protection temperature sensor installed on users water output, domestic hot water supply and return temperature sensors (only versions P2S), high pressure and low pressure automatic reset, compressor thermal protection, air fan, thermal protection, pressure transducer (used to optimize the defrost cycle and to adjust the fan speed depending on ambient conditions), flow switch.

All units are also fitted with a temperature probe sensor with "Energy Saving" function, supplied in a separate plastic box, which can be used to stop the pump use during periods of stand-by, when the water temperature reaches the set point. Doing this the power consumption of the unit is strongly reduced.

#### USER AND RECOVERY FLOW SWITCH (P4U/P4S VERSIONS)

The flow utility is installed as standard on all units and disables the operation of the unit in case of abnormal water flow in the system. The flow switch is made of a blade system fitted in the flow of the water; it is combined with two permanent magnets that assess the amount of water in transit and, in function of the measured parameter, enable or not the operation of the unit.

#### ELECTRONIC EXPANSION VALVE (VTEE)

The use of the electronic thermostatic valve is particularly suitable for units operating under very variable load conditions. The electronic expansion valve enables the maximum possible efficiency to be achieved by maximizing the evaporator heat exchange, minimizing the reaction time to load variations and optimizing the superheat. The use of the electronic thermostatic valve is particularly suitable for units operating under very variable load conditions.

## VERSIONS

#### P4S Version

This is a four pipe version that can produce hot water for heating (HH version), hot and cold water for cooling and domestic hot water (only RV versions) in all operational modes using an independent water circuit. When cooling, DHW generation is by heat recovery. This unit is normally used with two pipe water based change-over systems with the DHW circuit being separate.

#### P4U Version

This is a four pipe version that provides a modern approach to four pipe water based systems. Instead of using a boiler and chiller, this unit can generate hot water in one circuit, cold water in the other circuit either individually or simultaneously. When operating in simultaneous mode the heating capacity is equal to the cooling duty plus the power input to the compressors. The operating efficiency in this mode is extremely high. Domestic hot water production for this version is not available.

#### RV Version

This version uses 2 hydraulic connections and is able to produce hot water in winter and cold water in summer. The unit is combined with a 2-pipe system.

#### SE Version

Standard efficiency version, according to current standard. Unit equipped with EC fans.

#### LS Version

This version includes the complete acoustic insulation of the unit with compressor jackets and insulating material made with high density media and the interposition of heavy bitumen layer.

### P4U VERSION

User water heating

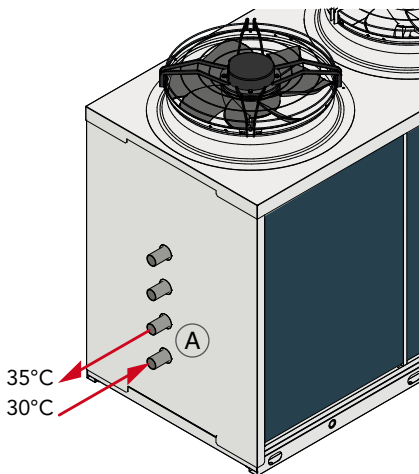

User water cooling

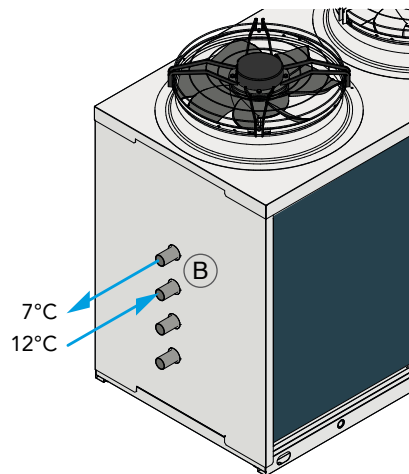

Simultaneous user Cooling + heating

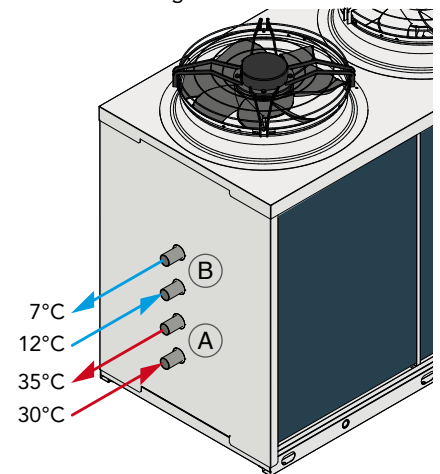

The above scheme is for illustrative purposes only. For the correct pipes placement, please refer to the units technical manual.

**XL Super low noise version**

All units in XL super low noise version are supplied, as standard, with the latest 'Floating Frame' technology that completely isolates the compressors from the main casing, thereby eliminating vibration and noise from this source. The 'Floating Frame' is a special vibration and acoustic damping system that consists of a base plate and acoustic enclosure that houses the compressors. The base plate is separated from the supporting frame of the unit by soft steel springs that have a high damping power. Within the enclosure, the compressors are mounted on rubber shock absorbers on the floating base plate. The enclosure is manufactured from galvanized steel sandwich panels that have a micro-perforated inner skin and a core of 30 mm thick, high density (25 kg/m<sup>3</sup>). The entire arrangement provides a double damping system and acoustic attenuation. The compressor refrigerant pipes are connected to the refrigerant circuit through "anaconda" flexible connections. Flexible connections are also used on the water pipework within the unit. The combination of these systems results in an overall noise reduction in the region of 5-7 dB(A).

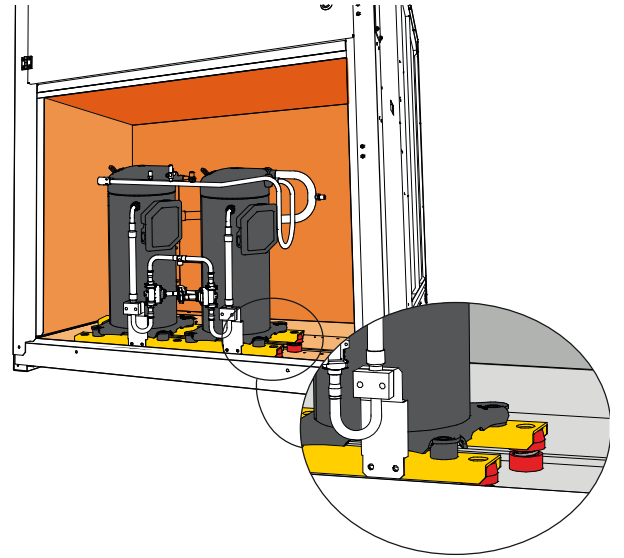

LHI/P4

**OPERATION LIMITS**

(SE versions)

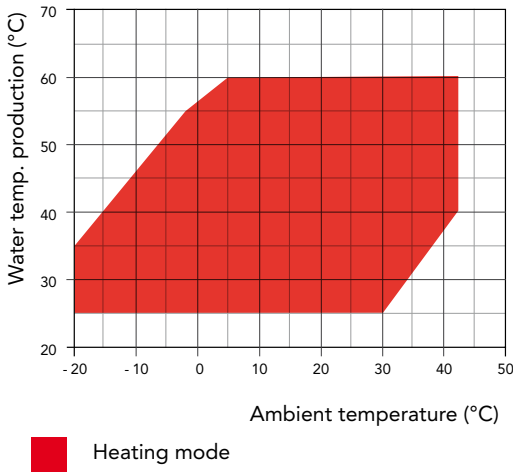

(RV versions Only)

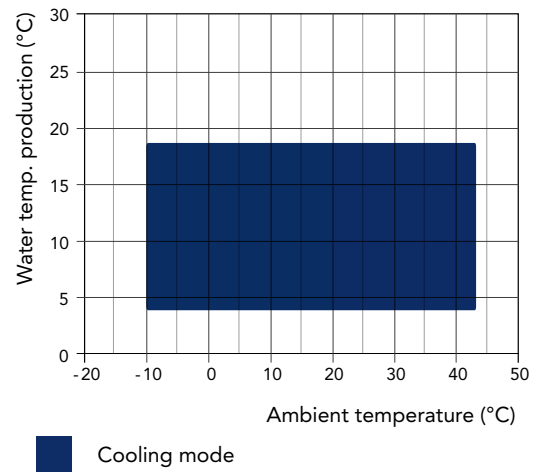

**P4S VERSION**

User water heating

User water cooling

Domestic hot water production (D.H.W.)

User water cooling + D.H.W. production

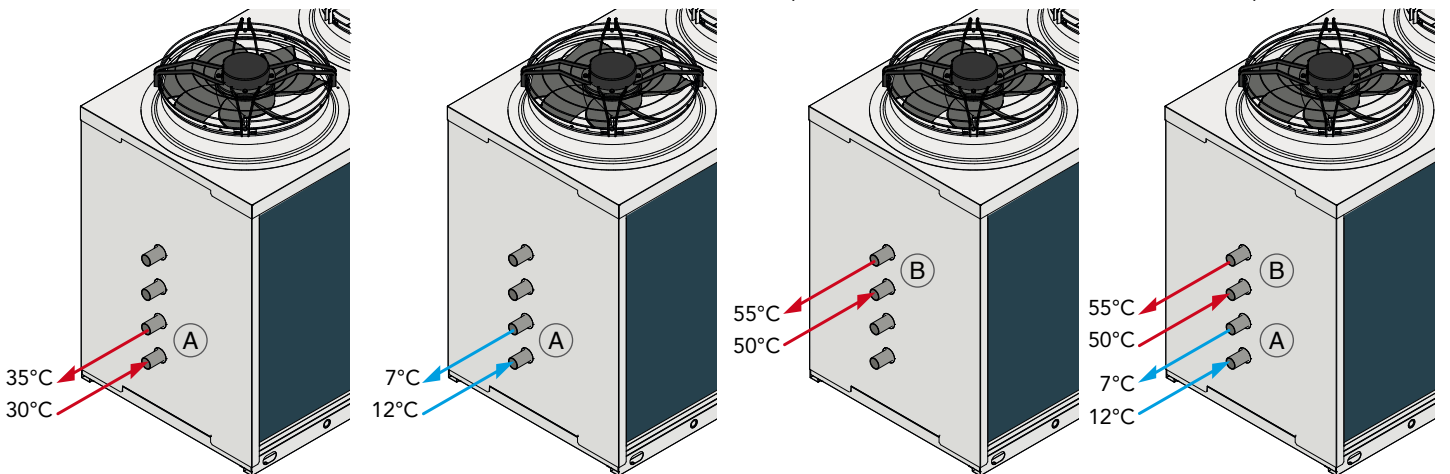

The above scheme is for illustrative purposes only. For the correct pipes placement, please refer to the units technical manual.

# ACCESSORIES

LHi/P4

LHi SE/HH-RV	P4S/P4U	532	632	742	862	912	1052	1222
Flow switch		●	●	●	●	●	●	●
"Floating frame" Technology - XL Version		●	●	●	●	●	●	●
E.C. fans - SE versions	VECE	●	●	●	●	●	●	●
Condensate discharge drip tray with antifreeze heater	BRCA	○	○	○	○	○	○	○
Antifreeze kit for 4 pipe units	RAEV4	○	○	○	○	○	○	○
Electronic soft starter	DSSE	○	○	○	○	○	○	○
Serial interface card RS485	INSE	●	●	●	●	●	●	●
Rubber anti-vibration mountings	KAVG	○	○	○	○	○	○	○
Remote control panel	PCRL	○	○	○	○	○	○	○
Electronic expansion valve	VTEE	●	●	●	●	●	●	●
Power factor correction system	RICO	○	○	○	○	○	○	○
Power factor correction system with soft starter	RICSS	○	○	○	○	○	○	○
Spring vibration dampers	KAVM	○	○	○	○	○	○	○
Coil protection grid	GBPE	○	○	○	○	○	○	○
Shut-off valve on compressor discharging side	RDCO	○	○	○	○	○	○	○
Shut-off valve on compressor suction side	RHCO	○	○	○	○	○	○	○
Hydraulic kit with one inverter pump	A1VSU	○	○	○	○	○	○	○
Hydraulic kit with one pump without tank	A1NTU	○	○	○	○	○	○	○
Hydraulic kit with one higher available pressure pump	A1HPU	○	○	○	○	○	○	○
Hydraulic kit with two pumps without tank	A2NTU	○	○	○	○	○	○	○
Hydraulic kit with tank and one inverter pump	A1VVU	○	○	○	○	○	○	○
Hydraulic kit with one pump with tank	A1ZZU	○	○	○	○	○	○	○
Hydraulic kit with tank and one one higher available pressure pump	A1HHU	○	○	○	○	○	○	○
Hydraulic kit with two pumps with tank	A2ZZU	○	○	○	○	○	○	○
Buffer tank and pump for internal loop	BUF4A	○	○	○	○	○	○	○
Hydraulic kit with one pump for heat recovery	A1NTR	○	○	○	○	○	○	○
Hydraulic kit with higher available pressure pump for heat recovery	A1HPR	○	○	○	○	○	○	○
Hydraulic kit with two pump for heat recovery	A2NTR	○	○	○	○	○	○	○
Antifreeze kit in combination with A1VSU / A1NTU / A1HPU *	KPU1	○	○	○	○	○	○	○
Antifreeze kit in combination with A2NTU *	KPU2	○	○	○	○	○	○	○
Antifreeze kit in combination with pump and buffer tank *	KPSU1	○	○	○	○	○	○	○
Antifreeze kit in combination with pumps and buffer tank *	KPSU2	○	○	○	○	○	○	○
Antifreeze kit in combination with A1NTR / A1HPR	KPR1	○	○	○	○	○	○	○
Antifreeze kit in combination with A2NTR	KPR2	○	○	○	○	○	○	○

\* Includes accessory RAEV2

● Standard ○ Optional – Not available

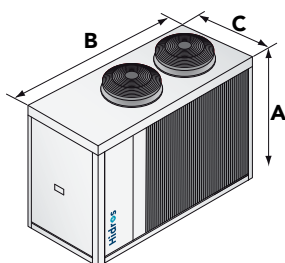

SE/LS 532  
SE/XL 532

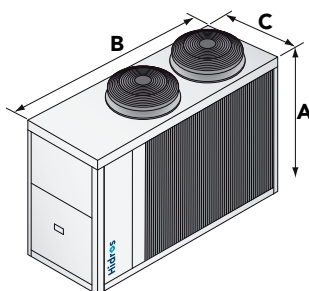

SE/LS 632 - 742  
SE/XL 632

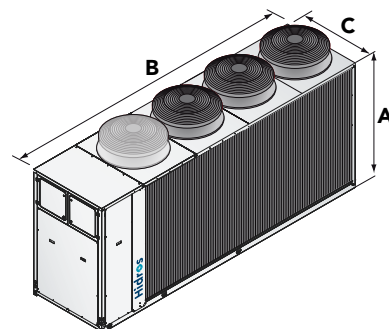

SE/LS 862 - 912 - 1052 - 1222  
SE/XL 742 - 862 - 912 - 1052 - 1222

		532	632	742	862	912	1052	1222
A (mm)	SE/LS	1690	1840	1840	1840	1840	1840	1840
B (mm)	SE/LS	2400	2905	2905	3905	3905	3905	3905
C (mm)	SE/LS	1145	1145	1145	1145	1145	1145	1145
kg	SE/LS	810	940	950	970	1270	1360	1410
A (mm)	SE/XL	1690	1840	1840	1840	1840	1840	1840
B (mm)	SE/XL	2400	2905	3905	3905	3905	3905	3905
C (mm)	SE/XL	1145	1145	1145	1145	1145	1145	1145
kg	SE/XL	830	960	970	990	1290	1380	1430

LHi SE/HH-RV	P4S/P4U	1534	1654	1854	1964	2254	2554
Flow switch		●	●	●	●	●	●
“Floating frame” Technology - XL Version		–	–	–	–	–	–
E.C. fans - SE versions	VECE	●	●	●	●	●	●
Condensate discharge drip tray with antifreeze heater	BRCA	○	○	○	○	○	○
Antifreeze kit for 4 pipe units	RAEV4	○	○	○	○	○	○
Electronic soft starter	DSSE	○	○	○	○	○	○
Serial interface card RS485	INSE	●	●	●	●	●	●
Rubber anti-vibration mountings	KAVG	○	○	○	○	○	○
Remote control panel	PCRL	○	○	○	○	○	○
Electronic expansion valve	VTEE	●	●	●	●	●	●
Power factor correction system	RICO	○	○	○	○	○	○
Power factor correction system with soft starter	RICSS	○	○	○	○	○	○
Spring vibration dampers	KAVM	○	○	○	○	○	○
Coil protection grid	GBPE	○	○	○	○	○	○
Shut-off valve on compressor discharging side	RDCO	○	○	○	○	○	○
Shut-off valve on compressor suction side	RHCO	○	○	○	○	○	○
Hydraulic kit with one inverter pump	A1VSU	○	○	○	○	○	○
Hydraulic kit with one pump without tank	A1NTU	○	○	○	○	○	○
Hydraulic kit with one higher available pressure pump	A1HPU	○	○	○	○	○	○
Hydraulic kit with two pumps without tank	A2NTU	○	○	○	○	○	○
Hydraulic kit with tank and one inverter pump	A1VVU	○	○	○	○	○	○
Hydraulic kit with one pump with tank	A1ZZU	○	○	○	○	○	○
Hydraulic kit with tank and one one higher available pressure pump	A1HHU	○	○	○	○	○	○
Hydraulic kit with two pumps with tank	A2ZZU	○	○	○	○	○	○
Buffer tank and pump for internal loop	BUF4A	○	○	○	○	○	○
Hydraulic kit with one pump for heat recovery	A1NTR	○	○	○	○	○	○
Hydraulic kit with higher available pressure pump for heat recovery	A1HPR	○	○	○	○	○	○
Hydraulic kit with two pump for heat recovery	A2NTR	○	○	○	○	○	○
Antifreeze kit in combination with A1VSU / A1NTU / A1HPU *	KPU1	○	○	○	○	○	○
Antifreeze kit in combination with A2NTU *	KPU2	○	○	○	○	○	○
Antifreeze kit in combination with pump and buffer tank *	KPSU1	○	○	○	○	○	○
Antifreeze kit in combination with pumps and buffer tank *	KPSU2	○	○	○	○	○	○
Antifreeze kit in combination with A1NTR / A1HPR	KPR1	○	○	○	○	○	○
Antifreeze kit in combination with A2NTR	KPR2	○	○	○	○	○	○

\* Includes accessory RAEV2

● Standard ○ Optional – Not available

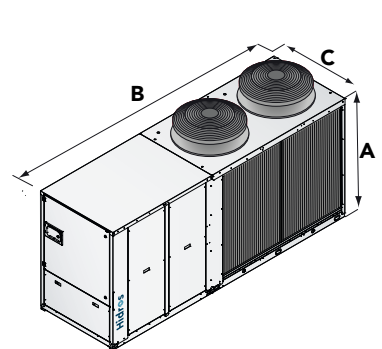

**SE/LS 1534**  
**SE/XL 1534**

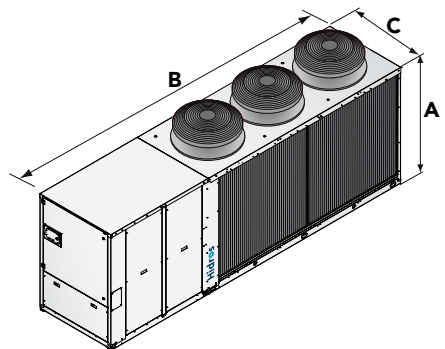

**SE/LS 1654 - 1854 - 1964**  
**SE/XL 1654 - 1854 - 1964**

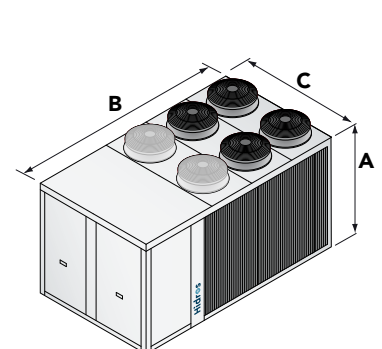

**SE/LS 2254 - 2554**  
**SE/XL 2254 - 2554**

		1534	1654	1854	1964	2254	2554
A (mm)	<b>SE/LS</b>	1890	1890	1890	1890	2350	2350
B (mm)	<b>SE/LS</b>	3695	4695	4695	4695	4205	4205
C (mm)	<b>SE/LS</b>	1145	1145	1145	1145	2190	2190
	<b>SE/LS</b>	1460	1810	1830	2130	2680	2720
A (mm)	<b>SE/XL</b>	1890	1890	1890	1890	2350	2350
B (mm)	<b>SE/XL</b>	3695	4695	4695	4695	4205	4205
C (mm)	<b>SE/XL</b>	1145	1145	1145	1145	2190	2190
	<b>SE/XL</b>	1480	1830	1850	2150	2700	2740

# LHNP4

## 4 PIPE SYSTEMS HIGH EFFICIENCY AIR TO WATER HEAT PUMPS

Heating capacity from 22 kW to 432 kW

R410A

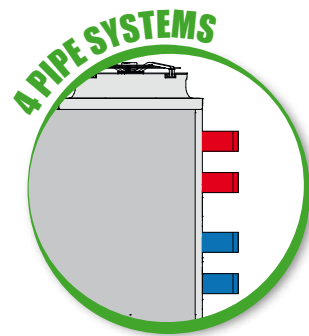
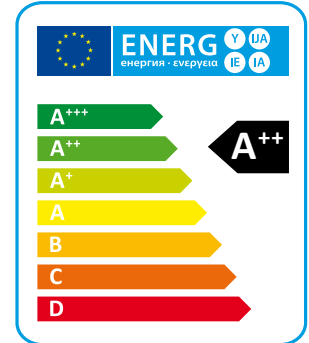

The high efficiency air / water heat pumps of the LHA series are units designed for 4-pipe air conditioning and heating systems, which allow the production of cold water for cooling and hot water for heating at the same time or separately.

The units are supplied with an additional exchanger, used as a condenser for hot water, the production of which is independent of the operation mode of the unit.

Activation of the exchanger takes place automatically via the microprocessor control when the hot water temperature on the return is lower than the set point. These units are able to produce hot water and cold water simultaneously and / or separately with very high energy efficiencies.

They are all supplied complete with a specific advanced microprocessor control provided with software for managing the various priorities.

The XL versions also have an extremely low noise level thanks to the use of a special floating vibration damping system that allows a noise reduction of about 6-8 dB (A) (optional).

### VERSIONS

- P4U** 4 pipe systems heating/cooling.
- P4S** 2+2 pipe systems with D.H.W. production.
- SA** Standard efficiency, AC fans.
- SE** Standard efficiency, EC fans.
- HA** High efficiency, AC fans.
- HE** High efficiency, EC fans.
- LS** Low noise.
- XL** Super low noise.



# TECHNICAL DATA

Reversible heating/cooling version (RV)

SA/LS/RV - P4S	242	292	402	432	492	592	702	802	902	1002	1202	1402	
Heating capacity (EN14511) <sup>(1)</sup> kW	22,0	28,7	34,5	47,2	50,9	56,8	64,9	73,2	80,2	97,0	105,7	122,3	
Total input power (EN14511) <sup>(1)</sup> kW	5,8	7,3	9,1	12,2	12,6	14,4	16,0	17,9	20,8	24,3	27,3	30,7	
COP (EN14511) <sup>(1)</sup>	W/W	3,83	3,93	3,80	3,86	4,04	3,94	4,06	4,10	3,86	4,00	3,87	3,98
Energy Class <sup>(2)</sup>		A+	A+	A+	A+	A+	A+	A+	A+	A+	A+	A+	A+
SCOP <sup>(2)</sup>	kWh/kWh	3,27	3,58	3,41	3,34	3,48	3,54	3,43	3,47	3,42	3,50	3,39	3,50
$\eta_{s,h}$ <sup>(2)</sup>	%	127,9	140,1	133,3	130,4	136,3	138,6	134,3	135,9	133,7	137,1	132,7	136,9
Cooling capacity (EN14511) <sup>(3)</sup> kW		17,8	24,1	28,4	38,8	42,7	48,2	55,2	60,2	69,7	83,3	91,6	102,6
Total input power (EN14511) <sup>(3)</sup> kW		7,1	9,8	11,7	15,0	16,4	19,8	21,9	24,5	29,3	32,7	37,7	42,6
EER (EN14511) <sup>(3)</sup>	W/W	2,52	2,45	2,42	2,58	2,61	2,43	2,52	2,46	2,38	2,55	2,43	2,41
TER (EN14511) <sup>(4)</sup>	W/W	8,76	9,43	9,02	8,58	9,28	9,55	9,58	9,29	9,13	9,34	9,14	9,23
Sound power <sup>(5)</sup>	dB (A)	75	75	75	75	77	77	77	78	79	82	83	85
Sound pressure <sup>(6)</sup>	dB (A)	43	43	43	43	45	45	45	46	47	50	51	53
SE/LS/RV - P4S	242	292	402	432	492	592	702	802	902	1002	1202	1402	
Heating capacity (EN14511) <sup>(1)</sup> kW	21,9	28,6	34,2	47,1	51,1	57,1	64,9	73,1	81,0	97,0	105,6	122,7	
Total input power (EN14511) <sup>(1)</sup> kW	5,6	7,2	8,8	11,9	12,4	14,4	15,8	17,6	20,9	24,0	27,3	30,5	
COP (EN14511) <sup>(1)</sup>	W/W	3,92	3,95	3,87	3,95	4,13	3,97	4,10	4,15	3,88	4,04	3,87	4,02
Energy Class <sup>(2)</sup>		A+	A+	A+	A+	A+	A+	A+	A+	A+	A+	A+	A+
SCOP <sup>(2)</sup>	kWh/kWh	3,40	3,66	3,53	3,46	3,59	3,62	3,68	3,71	3,63	3,71	3,64	3,73
$\eta_{s,h}$ <sup>(2)</sup>	%	132,8	143,2	138,3	135,5	140,4	141,7	144,1	145,4	142,1	145,3	142,5	146,1
Cooling capacity (EN14511) <sup>(3)</sup> kW		17,7	24,1	28,2	39,0	43,5	48,9	55,6	61,3	70,3	84,3	92,0	103,5
Total input power (EN14511) <sup>(3)</sup> kW		7,0	9,8	11,8	14,9	16,0	19,5	21,8	24,0	28,9	32,3	37,4	42,2
EER (EN14511) <sup>(3)</sup>	W/W	2,52	2,47	2,40	2,61	2,72	2,51	2,55	2,55	2,43	2,61	2,46	2,45
TER (EN14511) <sup>(4)</sup>	W/W	8,76	9,43	9,02	8,58	9,28	9,55	9,58	9,29	9,13	9,34	9,14	9,23
Sound power <sup>(5)</sup>	dB (A)	74	74	75	75	77	77	77	78	79	82	83	85
Sound pressure <sup>(6)</sup>	dB (A)	42	42	43	43	45	45	45	46	47	50	51	53
Power supply	V/Ph/Hz	400/3+N/50 400/3+N/50 400/3+N/50 400/3+N/50 400/3/50 400/3/50 400/3/50 400/3/50 400/3/50 400/3/50 400/3/50 400/3/50 400/3/50											
Compressors / Circuits	n° / n°	2 / 1	2 / 1	2 / 1	2 / 1	2 / 1	2 / 1	2 / 1	2 / 1	2 / 1	2 / 1	2 / 1	2 / 1
Fans	n°	1	1	2	2	2	2	2	2	2	3	3	3
Refrigerant		R410A	R410A	R410A	R410A	R410A	R410A	R410A	R410A	R410A	R410A	R410A	R410A
Refrigerant charge	kg	10,0	10,0	10,0	10,0	14,5	14,5	14,5	14,5	14,5	21,0	21,0	27,0
Global warming potential (GWP)		2088	2088	2088	2088	2088	2088	2088	2088	2088	2088	2088	2088
Equivalent CO <sub>2</sub> charge	t	20,88	20,88	20,88	20,88	30,27	30,27	30,27	30,27	30,27	43,84	43,84	56,37
Water tank volume	l	100	100	100	100	100	100	100	300	300	500	500	500

SA/LS/RV - P4S	1602	1802	2002	2302	2502	2504	3004	3204	3504	4004	4504	5004 *	
Heating capacity (EN14511) <sup>(1)</sup> kW	136,0	157,3	169,0	196,6	215,0	211,8	226,1	258,8	330,6	357,4	393,3	431,7	
Total input power (EN14511) <sup>(1)</sup> kW	34,6	40,3	43,4	51,5	60,4	58,2	64,8	71,9	85,2	93,8	103,0	116,4	
COP (EN14511) <sup>(1)</sup>	W/W	3,93	3,90	3,89	3,82	3,56	3,64	3,49	3,60	3,88	3,81	3,71	
Energy Class <sup>(2)</sup>		A+	A+	A+	A+	A+	A+	A+	A+	A+	A+	A+	
SCOP <sup>(2)</sup>	kWh/kWh	3,50	3,48	3,46	3,45	3,24	3,25	3,23	3,26	3,25	3,27	3,24	3,34
$\eta_{s,h}$ <sup>(2)</sup>	%	137,0	136,1	135,5	134,8	126,5	127,1	126,1	127,2	127,0	127,8	126,4	130,4
Cooling capacity (EN14511) <sup>(3)</sup> kW		115,6	131,9	143,0	173,0	197,2	192,3	210,8	231,8	286,3	312,9	349,4	401,8
Total input power (EN14511) <sup>(3)</sup> kW		47,2	53,8	63,6	68,9	76,7	76,0	87,5	97,8	106,0	121,8	138,1	153,4
EER (EN14511) <sup>(3)</sup>	W/W	2,45	2,45	2,25	2,51	2,57	2,53	2,41	2,37	2,70	2,57	2,53	2,62
TER (EN14511) <sup>(4)</sup>	W/W	9,25	9,33	9,39	9,34	9,40	9,06	8,97	8,94	9,42	9,50	9,24	9,37
Sound power <sup>(5)</sup>	dB (A)	86	86	86	89	90	87	89	90	90	90	92	93
Sound pressure <sup>(6)</sup>	dB (A)	54	54	54	57	58	55	57	58	58	58	60	61
SE/LS/RV - P4S	1602	1802	2002	2302	2502	2504	3004	3204	3504	4004	4504	5004 *	
Heating capacity (EN14511) <sup>(1)</sup> kW	137,0	157,8	170,2	197,7	217,6	213,2	227,7	261,7	330,6	357,5	396,6	435,4	
Total input power (EN14511) <sup>(1)</sup> kW	34,6	38,8	43,3	51,5	60,3	57,9	65,1	71,9	82,9	92,1	102,7	116,7	
COP (EN14511) <sup>(1)</sup>	W/W	3,96	4,07	3,93	3,84	3,61	3,68	3,50	3,64	3,99	3,88	3,86	3,73
Energy Class <sup>(2)</sup>		A+	A+	A+	A+	A+	A+	A+	A+	A+	A+	A+	
SCOP <sup>(2)</sup>	kWh/kWh	3,68	3,77	3,72	3,74	3,63	3,54	3,49	3,46	3,52	3,57	3,63	3,58
$\eta_{s,h}$ <sup>(2)</sup>	%	144,0	147,8	145,8	146,4	142,1	138,6	136,5	135,2	137,9	139,6	142,3	140,0
Cooling capacity (EN14511) <sup>(3)</sup> kW		116,4	132,9	147,1	175,3	200,4	195,8	212,1	233,3	289,3	321,1	357,3	408,0
Total input power (EN14511) <sup>(3)</sup> kW		46,9	53,4	61,0	67,9	75,6	74,4	86,9	96,8	104,8	118,1	135,9	150,0
EER (EN14511) <sup>(3)</sup>	W/W	2,48	2,49	2,41	2,58	2,65	2,63	2,44	2,41	2,76	2,72	2,63	2,72
TER (EN14511) <sup>(4)</sup>	W/W	9,25	9,33	9,39	9,34	9,40	9,06	8,97	8,94	9,42	9,50	9,24	9,37
Sound power <sup>(5)</sup>	dB (A)	86	86	86	89	90	87	89	90	90	90	92	93
Sound pressure <sup>(6)</sup>	dB (A)	54	54	54	57	58	55	57	58	58	58	60	61
Power supply	V/Ph/Hz	400/3/50 400/3/50 400/3/50 400/3/50 400/3/50 400/3/50 400/3/50 400/3/50 400/3/50 400/3/50 400/3/50 400/3/50 400/3/50											
Compressors / Circuits	n° / n°	2 / 1	2 / 1	2 / 1	2 / 1	2 / 1	4 / 2	4 / 2	4 / 2	4 / 2	4 / 2	4 / 2	4 / 2
Fans	n°	4	4	4	3	4	4	4	4	6	6	6	8
Refrigerant		R410A	R410A	R410A	R410A	R410A	R410A	R410A	R410A	R410A	R410A	R410A	R410A
Refrigerant charge	kg	27,0	36,0	36,0	45,0	45,0	45,0	54,0	54,0	72,0	80,0	90,0	100,0
Global warming potential (GWP)		2088	2088	2088	2088	2088	2088	2088	2088	2088	2088	2088	2088
Equivalent CO <sub>2</sub> charge	t	56,37	75,16	75,16	93,96	93,96	93,96	112,75	112,75	150,33	167,04	187,92	208,80
Water tank volume	l	500	500	500	500	500	500	500	500	1000	1000	1000	1000

\* Units only available for the non-EU market

Performances are referred to the following conditions:

- (1) Heating: Ambient temperature 7°C DB, 6°C WB, water temperature 30/35°C.
- (2) Average conditions, low temperature, variable - Reg EU 811/2013
- (3) Cooling: ambient air temperature 35°C, evaporator water temperature in/out 12/7 °C.

(4) TER: Total Energy Ratio - cold circuit 12/7°C, hot circuit 30/35°C.

(5) Sound power level in accordance with ISO 3744.

(6) Sound pressure level at 10 mt from the unit in free field conditions in accordance with ISO 3744.

LHM/P4

Reversible heating/cooling version (RV)

SA/LS/RV - P4U	242	292	402	432	492	592	702	802	902	1002	1202	1402
Heating capacity (EN14511) <sup>(1)</sup> kW	22,0	28,7	34,5	47,2	50,9	56,8	67,0	75,4	82,6	101,0	107,9	125,9
Total input power (EN14511) <sup>(1)</sup> kW	5,8	7,3	9,1	12,2	12,6	14,4	16,1	18,0	21,0	24,5	27,5	31,0
COP (EN14511) <sup>(1)</sup>	W/W	3,83	3,93	3,80	3,86	4,04	3,94	4,17	4,19	3,94	4,12	3,92
Energy Class <sup>(2)</sup>	A+	A+	A+	A+	A+	A+	A+	A+	A+	A+	A+	A+
SCOP <sup>(2)</sup>	kWh/kWh	3,27	3,58	3,41	3,34	3,48	3,54	3,50	3,54	3,52	3,58	3,46
$\eta_{s,h}$ <sup>(2)</sup>	%	127,9	140,1	133,3	130,4	136,3	138,6	137,1	138,5	137,9	140,0	135,4
Cooling capacity (EN14511) <sup>(3)</sup> kW	17,8	24,1	28,4	38,8	42,7	48,2	55,2	60,2	69,7	83,3	91,6	102,6
Total input power (EN14511) <sup>(3)</sup> kW	7,1	9,8	11,7	15,0	16,4	19,8	21,9	24,5	29,3	32,7	37,7	42,6
EER (EN14511) <sup>(3)</sup>	W/W	2,52	2,45	2,42	2,58	2,61	2,43	2,52	2,46	2,38	2,55	2,43
TER (EN14511) <sup>(4)</sup>	W/W	8,76	9,43	9,02	8,58	9,28	9,55	9,58	9,29	9,13	9,34	9,14
Sound power <sup>(5)</sup>	dB (A)	75	75	75	75	77	77	77	78	79	82	83
Sound pressure <sup>(6)</sup>	dB (A)	43	43	43	43	45	45	45	46	47	50	51
SE/LS/RV - P4U	242	292	402	432	492	592	702	802	902	1002	1202	1402
Heating capacity (EN14511) <sup>(1)</sup> kW	21,9	28,6	34,2	47,1	51,1	57,1	67,2	75,7	83,5	101,3	108,7	126,6
Total input power (EN14511) <sup>(1)</sup> kW	5,6	7,2	8,8	11,9	12,4	14,4	16,0	17,9	21,0	24,3	27,5	30,9
COP (EN14511) <sup>(1)</sup>	W/W	3,92	3,95	3,87	3,95	4,13	3,97	4,20	4,23	3,98	4,17	3,96
Energy Class <sup>(2)</sup>	A+	A+	A+	A+	A+	A+	A+	A+	A+	A++	A+	A++
SCOP <sup>(2)</sup>	kWh/kWh	3,40	3,66	3,53	3,46	3,59	3,62	3,77	3,80	3,72	3,79	3,73
$\eta_{s,h}$ <sup>(2)</sup>	%	132,8	143,2	138,3	135,5	140,4	141,7	147,7	148,9	145,6	148,6	146,2
Cooling capacity (EN14511) <sup>(3)</sup> kW	17,7	24,1	28,2	39,0	43,5	48,9	55,6	61,3	70,3	84,3	92,0	103,5
Total input power (EN14511) <sup>(3)</sup> kW	7,0	9,8	11,8	14,9	16,0	19,5	21,8	24,0	28,9	32,3	37,4	42,2
EER (EN14511) <sup>(3)</sup>	W/W	2,52	2,47	2,40	2,61	2,72	2,51	2,55	2,55	2,43	2,61	2,46
TER (EN14511) <sup>(4)</sup>	W/W	8,76	9,43	9,02	8,58	9,28	9,55	9,58	9,29	9,13	9,34	9,14
Sound power <sup>(5)</sup>	dB (A)	74	74	75	75	77	77	77	78	79	82	83
Sound pressure <sup>(6)</sup>	dB (A)	42	42	43	43	45	45	45	46	47	50	51
Power supply	V/Ph/Hz	400/3+N/50	400/3+N/50	400/3+N/50	400/3/50	400/3/50	400/3/50	400/3/50	400/3/50	400/3/50	400/3/50	400/3/50
Compressors / Circuits	n° / n°	2 / 1	2 / 1	2 / 1	2 / 1	2 / 1	2 / 1	2 / 1	2 / 1	2 / 1	2 / 1	2 / 1
Fans	n°	1	1	2	2	2	2	2	2	3	3	3
Refrigerant		R410A	R410A	R410A	R410A	R410A	R410A	R410A	R410A	R410A	R410A	R410A
Refrigerant charge	kg	10,0	10,0	10,0	10,0	14,5	14,5	14,5	14,5	21,0	21,0	27,0
Global warming potential (GWP)		2088	2088	2088	2088	2088	2088	2088	2088	2088	2088	2088
Equivalent CO <sub>2</sub> charge	t	20,88	20,88	20,88	20,88	30,27	30,27	30,27	30,27	43,84	43,84	56,37
Water tank volume	l	100	100	100	100	100	100	300	300	500	500	500

SA/LS/RV - P4U	1602	1802	2002	2302	2502	2504	3004	3204	3504	4004	4504	5004 *
Heating capacity (EN14511) <sup>(1)</sup> kW	140,0	161,8	173,5	202,7	222,9	218,3	234,8	268,5	341,0	369,9	393,3	444,9
Total input power (EN14511) <sup>(1)</sup> kW	35,0	39,4	43,6	51,9	59,1	59,5	66,2	73,6	85,4	93,8	103,0	118,7
COP (EN14511) <sup>(1)</sup>	W/W	4,00	4,11	3,98	3,90	3,77	3,67	3,55	3,65	3,99	3,94	3,82
Energy Class <sup>(2)</sup>	A+	A+	A+	A+	A+	A+	A+	A+	A+	A+	A+	A+
SCOP <sup>(2)</sup>	kWh/kWh	3,57	3,54	3,54	3,51	3,39	3,30	3,27	3,28	3,33	3,34	3,28
$\eta_{s,h}$ <sup>(2)</sup>	%	139,6	138,4	138,4	137,4	132,5	128,8	127,7	128,3	130,2	130,6	132,2
Cooling capacity (EN14511) <sup>(3)</sup> kW	115,6	131,9	143,0	173,0	197,2	192,3	210,8	231,8	286,3	312,9	349,4	401,8
Total input power (EN14511) <sup>(3)</sup> kW	47,2	53,8	63,6	68,9	76,7	76,0	87,5	97,8	106,0	121,8	138,1	153,4
EER (EN14511) <sup>(3)</sup>	W/W	2,45	2,45	2,25	2,51	2,57	2,53	2,41	2,37	2,70	2,57	2,62
TER (EN14511) <sup>(4)</sup>	W/W	9,25	9,33	9,39	9,34	9,40	9,06	8,97	8,94	9,42	9,50	9,24
Sound power <sup>(5)</sup>	dB (A)	86	86	86	89	90	87	89	90	90	92	93
Sound pressure <sup>(6)</sup>	dB (A)	54	54	54	57	58	55	57	58	58	60	61
SE/LS/RV - P4U	1602	1802	2002	2302	2502	2504	3004	3204	3504	4004	4504	5004 *
Heating capacity (EN14511) <sup>(1)</sup> kW	141,2	163,4	175,6	204,4	224,8	219,9	236,7	272,7	339,6	371,9	396,6	449,7
Total input power (EN14511) <sup>(1)</sup> kW	35,0	39,3	43,6	52,0	59,1	59,4	66,3	73,8	83,0	92,3	102,7	118,8
COP (EN14511) <sup>(1)</sup>	W/W	4,04	4,16	4,03	3,93	3,80	3,70	3,57	3,70	4,09	4,03	3,86
Energy Class <sup>(2)</sup>	A+	A++	A+	A+	A+	A+	A+	A+	A+	A+	A+	A+
SCOP <sup>(2)</sup>	kWh/kWh	3,77	3,84	3,78	3,82	3,80	3,56	3,51	3,48	3,63	3,66	3,64
$\eta_{s,h}$ <sup>(2)</sup>	%	147,6	150,5	148,3	149,9	149,1	139,2	137,4	136,3	142,1	143,3	142,6
Cooling capacity (EN14511) <sup>(3)</sup> kW	116,4	132,9	147,1	175,3	200,4	195,8	212,1	233,3	289,3	321,1	357,3	408,0
Total input power (EN14511) <sup>(3)</sup> kW	46,9	53,4	61,0	67,9	75,6	74,4	86,9	96,8	104,8	118,1	135,9	150,0
EER (EN14511) <sup>(3)</sup>	W/W	2,48	2,49	2,41	2,58	2,65	2,63	2,44	2,41	2,76	2,72	2,62
TER (EN14511) <sup>(4)</sup>	W/W	9,25	9,33	9,39	9,34	9,40	9,06	8,97	8,94	9,42	9,50	9,24
Sound power <sup>(5)</sup>	dB (A)	86	86	86	89	90	87	89	90	90	92	93
Sound pressure <sup>(6)</sup>	dB (A)	54	54	54	57	58	55	57	58	58	60	61
Power supply	V/Ph/Hz	400/3/50	400/3/50	400/3/50	400/3/50	400/3/50	400/3/50	400/3/50	400/3/50	400/3/50	400/3/50	400/3/50
Compressors / Circuits	n° / n°	2 / 1	2 / 1	2 / 1	2 / 1	2 / 1	4 / 2	4 / 2	4 / 2	4 / 2	4 / 2	4 / 2
Fans	n°	4	4	4	3	4	4	4	6	6	6	8
Refrigerant		R410A	R410A	R410A	R410A	R410A	R410A	R410A	R410A	R410A	R410A	R410A
Refrigerant charge	kg	27,0	36,0	36,0	45,0	45,0	54,0	54,0	72,0	80,0	90,0	100,0
Global warming potential (GWP)		2088	2088	2088	2088	2088	2088	2088	2088	2088	2088	2088
Equivalent CO <sub>2</sub> charge	t	56,37	75,16	75,16	93,96	93,96	112,75	112,75	150,33	167,04	187,92	208,80
Water tank volume	l	500	500	500	500	500	500	500	1000	1000	1000	1000

\* Units only available for the non-EU market

Performances are referred to the following conditions:  
 (1) Heating: Ambient temperature 7°C DB, 6°C WB, water temperature 30/35°C.  
 (2) Average conditions, low temperature, variable - Reg EU 811/2013  
 (3) Cooling: ambient air temperature 35°C, evaporator water temperature in/out 12/7°C.

(4) TER: Total Energy Ratio - cold circuit 12/7°C, hot circuit 30/35°C.  
 (5) Sound power level in accordance with ISO 3744.  
 (6) Sound pressure level at 10 mt from the unit in free field conditions in accordance with ISO 3744.

Reversible heating/cooling version (RV)

Table with columns for HA/LS/RV - P4S and HE/LS/RV - P4S. Rows include Heating capacity, Total input power, COP, Energy Class, SCOP, ηs,h, Cooling capacity, EER, TER, Sound power, Sound pressure, Power supply, Compressors / Circuits, Fans, Refrigerant, Refrigerant charge, Global warming potential (GWP), Equivalent CO2 charge, and Water tank volume. Values range from 242 to 1402 kW and 2 to 54 fans.

Table with columns for HA/LS/RV - P4S and HE/LS/RV - P4S. Rows include Heating capacity, Total input power, COP, Energy Class, SCOP, ηs,h, Cooling capacity, EER, TER, Sound power, Sound pressure, Power supply, Compressors / Circuits, Fans, Refrigerant, Refrigerant charge, Global warming potential (GWP), Equivalent CO2 charge, and Water tank volume. Values range from 1602 to 5004 kW and 2 to 8 fans.

\* Units only available for the non-EU market

- Performances are referred to the following conditions:
(1) Heating: Ambient temperature 7°C DB, 6°C WB, water temperature 30/35°C.
(2) Average conditions, low temperature, variable - Reg EU 811/2013
(3) Cooling: ambient air temperature 35°C, evaporator water temperature in/out 12/7 °C.

- (4) TER: Total Energy Ratio - cold circuit 12/7°C, hot circuit 30/35°C.
(5) Sound power level in accordance with ISO 3744.
(6) Sound pressure level at 10 mt from the unit in free field conditions in accordance with ISO 3744.

## Reversible heating/cooling version (RV)

HA/LS/RV - P4U	242	292	412	432	492	602	702	802	902	1002	1202	1402
Heating capacity (EN14511) <sup>(1)</sup> kW	22,9	30,5	37,3	46,9	50,7	63,6	69,6	75,0	96,6	108,3	118,1	142,2
Total input power (EN14511) <sup>(1)</sup> kW	5,6	7,3	9,0	11,4	12,0	13,7	15,5	17,1	22,3	25,5	28,7	32,6
COP (EN14511) <sup>(1)</sup>	W/W	4,11	4,20	4,13	4,11	4,22	4,64	4,50	4,33	4,24	4,11	4,36
Energy Class <sup>(2)</sup>		A+	A+	A+	A+	A+	A++	A++	A++	A+	A+	A+
SCOP <sup>(2)</sup>	kWh/kWh	3,47	3,76	3,53	3,57	3,67	4,04	4,00	3,95	3,76	3,73	3,76
$\eta_{s,h}$ <sup>(2)</sup>	%	135,7	147,4	138,0	139,6	143,8	158,5	156,8	155,0	147,4	146,1	148,3
Cooling capacity (EN14511) <sup>(3)</sup> kW	18,1	24,5	30,8	39,9	44,2	52,3	57,4	62,6	79,8	89,6	97,8	117,0
Total input power (EN14511) <sup>(3)</sup> kW	7,0	9,6	10,9	15,0	16,3	18,4	21,5	24,5	27,2	31,7	36,5	43,8
EER (EN14511) <sup>(3)</sup>	W/W	2,57	2,56	2,84	2,65	2,72	2,84	2,67	2,55	2,93	2,83	2,68
TER (EN14511) <sup>(4)</sup>	W/W	9,05	9,43	9,56	9,54	10,41	10,48	10,42	10,43	9,84	9,63	9,46
Sound power <sup>(5)</sup>	dB (A)	75	75	75	75	76	76	77	78	82	83	85
Sound pressure <sup>(6)</sup>	dB (A)	43	43	43	43	44	44	45	46	50	51	53
Power supply	V/Ph/Hz	400/3+N/50	400/3+N/50	400/3/50	400/3/50	400/3/50	400/3/50	400/3/50	400/3/50	400/3/50	400/3/50	400/3/50
Compressors / Circuits	n° / n°	2 / 1	2 / 1	2 / 1	2 / 1	2 / 1	2 / 1	2 / 1	2 / 1	2 / 1	2 / 1	2 / 1
Fans	n°	2	2	2	2	2	2	2	2	2	2	3
Refrigerant		R410A	R410A	R410A	R410A	R410A	R410A	R410A	R410A	R410A	R410A	R410A
Refrigerant charge	kg	10,0	10,0	10,0	10,0	14,5	19,0	19,0	19,0	27,0	27,0	36,0
Global warming potential (GWP)		2088	2088	2088	2088	2088	2088	2088	2088	2088	2088	2088
Equivalent CO <sub>2</sub> charge	t	20,88	20,88	20,88	20,88	30,28	39,67	39,67	39,67	56,38	56,38	75,17
Water tank volume	l	100	100	100	100	100	300	300	300	300	300	500

HA/LS/RV - P4U	1602	1802	2002	2302	2502	2504	3004	3204	3504	4004	4504	5004 *
Heating capacity (EN14511) <sup>(1)</sup> kW	156,2	173,5	188,7	216,2	247,7	235,9	279,5	306,4	337,5	372,8	398,6	474,8
Total input power (EN14511) <sup>(1)</sup> kW	36,0	40,5	45,3	50,6	56,1	58,1	68,5	74,6	83,5	92,1	103,5	118,9
COP (EN14511) <sup>(1)</sup>	W/W	4,34	4,28	4,17	4,27	4,41	4,06	4,08	4,11	4,04	4,05	3,99
Energy Class <sup>(2)</sup>		A+	A++	A+	A++	A++	A+	A+	A+	A+	A+	A+
SCOP <sup>(2)</sup>	kWh/kWh	3,81	3,83	3,77	3,85	3,96	3,68	3,63	3,74	3,74	3,75	3,66
$\eta_{s,h}$ <sup>(2)</sup>	%	149,2	150,0	147,8	151,0	155,5	144,2	142,2	146,5	146,6	146,8	143,5
Cooling capacity (EN14511) <sup>(3)</sup> kW	129,5	144,5	159,3	180,2	199,7	197,4	230,1	257,2	288,2	325,6	366,0	405,0
Total input power (EN14511) <sup>(3)</sup> kW	44,3	51,8	58,8	66,3	74,5	73,1	81,9	91,5	105,6	116,7	136,1	155,2
EER (EN14511) <sup>(3)</sup>	W/W	2,92	2,79	2,71	2,72	2,68	2,70	2,81	2,81	2,73	2,79	2,61
TER (EN14511) <sup>(4)</sup>	W/W	9,87	9,99	9,90	9,79	9,74	9,27	9,18	9,60	9,68	9,71	9,62
Sound power <sup>(5)</sup>	dB (A)	87	87	87	89	91	88	89	90	90	90	92
Sound pressure <sup>(6)</sup>	dB (A)	55	55	55	57	59	56	57	58	58	58	60
Power supply	V/Ph/Hz	400/3/50	400/3/50	400/3/50	400/3/50	400/3/50	400/3/50	400/3/50	400/3/50	400/3/50	400/3/50	400/3/50
Compressors / Circuits	n° / n°	2 / 1	2 / 1	2 / 1	2 / 1	2 / 1	4 / 2	4 / 2	4 / 2	4 / 2	4 / 2	4 / 2
Fans	n°	3	3	3	3	3	4	6	6	6	8	8
Refrigerant		R410A	R410A	R410A	R410A	R410A	R410A	R410A	R410A	R410A	R410A	R410A
Refrigerant charge	kg	36,0	36,0	45,0	45,0	60,0	60,0	72,0	72,0	90,0	90,0	100,0
Global warming potential (GWP)		2088	2088	2088	2088	2088	2088	2088	2088	2088	2088	2088
Equivalent CO <sub>2</sub> charge	t	75,16	75,16	93,96	93,96	125,28	125,28	150,33	150,33	150,33	187,92	208,80
Water tank volume	l	500	500	500	500	500	1000	1000	1000	1000	1000	1000

\* Units only available for the non-EU market

Performances are referred to the following conditions:

- (1) Heating: Ambient temperature 7°C DB, 6°C WB, water temperature 30/35°C.
- (2) Average conditions, low temperature, variable - Reg EU 811/2013
- (3) Cooling: ambient air temperature 35°C, evaporator water temperature in/out 12/7 °C.

(4) TER: Total Energy Ratio - cold circuit 12/7°C, hot circuit 30/35°C.

(5) Sound power level in accordance with ISO 3744.

(6) Sound pressure level at 10 mt from the unit in free field conditions in accordance with ISO 3744.

Reversible heating/cooling version (RV)

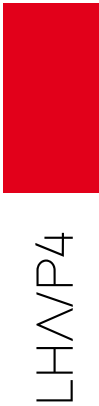

LHM/P4

HA/XL/RV - P4S	252	302	412	432	492	602	702	802	902	1002	1202	1402
Heating capacity (EN14511) <sup>(1)</sup> kW	23,1	29,8	36,8	46,2	49,4	60,1	65,9	71,0	91,6	101,7	111,1	134,8
Total input power (EN14511) <sup>(1)</sup> kW	5,6	7,2	8,8	11,2	11,7	13,4	15,1	16,7	20,9	23,9	27,0	30,5
COP (EN14511) <sup>(1)</sup>	W/W	4,12	4,13	4,20	4,12	4,21	4,50	4,35	4,25	4,39	4,26	4,41
Energy Class <sup>(2)</sup>		A+	A+	A+	A+	A+	A++	A++	A++	A++	A++	A++
SCOP <sup>(2)</sup>	kWh/kWh	3,36	3,58	3,68	3,65	3,77	4,04	3,96	3,89	3,88	3,87	3,72
η <sub>s,h</sub> <sup>(2)</sup>	%	131,2	140,2	144,0	143,0	147,9	158,6	155,4	152,7	152,2	151,6	145,7
Cooling capacity (EN14511) <sup>(3)</sup> kW	19,5	24,7	29,7	38,9	42,8	50,4	55,7	60,3	78,1	86,4	94,1	114,3
Total input power (EN14511) <sup>(3)</sup> kW	7,2	9,7	11,2	15,4	16,7	19,1	22,0	25,1	26,7	31,5	36,8	39,0
EER (EN14511) <sup>(3)</sup>	W/W	2,72	2,55	2,65	2,54	2,57	2,64	2,53	2,40	2,93	2,74	2,93
TER (EN14511) <sup>(4)</sup>	W/W	9,44	9,43	9,56	9,54	10,41	10,48	10,42	10,43	9,84	9,63	9,46
Sound power <sup>(5)</sup>	dB (A)	70	70	70	70	72	72	72	73	75	76	78
Sound pressure <sup>(6)</sup>	dB (A)	38	38	38	38	40	40	40	41	43	44	46

HE/XL/RV - P4S	252	302	412	432	492	602	702	802	902	1002	1202	1402	
Heating capacity (EN14511) <sup>(1)</sup> kW	23,1	29,8	36,9	46,3	49,7	60,0	65,9	71,0	91,4	101,4	111,0	134,5	
Total input power (EN14511) <sup>(1)</sup> kW	5,5	7,1	8,5	11,1	11,4	13,1	14,9	16,6	20,3	23,4	26,4	29,6	
COP (EN14511) <sup>(1)</sup>	W/W	4,23	4,18	4,34	4,16	4,35	4,42	4,29	4,51	4,34	4,21	4,55	
Energy Class <sup>(2)</sup>		A++	A++	A++	A++	A++	A++	A++	A++	A++	A++	A++	
SCOP <sup>(2)</sup>	kWh/kWh	3,83	3,86	3,92	3,91	3,98	4,19	4,09	4,00	4,05	4,01	3,86	
η <sub>s,h</sub> <sup>(2)</sup>	%	150,2	151,3	153,8	153,2	156,2	164,5	160,6	156,9	158,8	157,4	151,5	
Cooling capacity (EN14511) <sup>(3)</sup> kW	19,7	25,4	30,4	39,9	44,1	52,4	57,5	63,4	80,5	90,2	100,5	117,4	
Total input power (EN14511) <sup>(3)</sup> kW	7,0	9,3	10,9	14,9	16,2	18,3	21,3	24,0	26,6	31,2	35,2	38,6	
EER (EN14511) <sup>(3)</sup>	W/W	2,83	2,73	2,78	2,67	2,72	2,87	2,70	2,65	3,03	2,89	3,04	
TER (EN14511) <sup>(4)</sup>	W/W	9,44	9,43	9,56	9,54	10,41	10,48	10,42	10,43	9,84	9,63	9,46	
Sound power <sup>(5)</sup>	dB (A)	68	68	68	69	72	72	73	74	76	78	79	
Sound pressure <sup>(6)</sup>	dB (A)	36	36	36	37	40	40	40	41	42	44	46	
Power supply	V/Ph/Hz	400/3+N/50 400/3+N/50 400/3/50 400/3/50 400/3/50 400/3/50 400/3/50 400/3/50 400/3/50 400/3/50 400/3/50 400/3/50 400/3/50											
Compressors / Circuits	n° / n°	2 / 1 2 / 1 2 / 1 2 / 1 2 / 1 2 / 1 2 / 1 2 / 1 2 / 1 2 / 1 2 / 1 2 / 1 2 / 1											
Fans	n°	2 2 2 2 2 2 2 2 2 2 2 2 3											
Refrigerant		R410A R410A R410A R410A R410A R410A R410A R410A R410A R410A R410A R410A R410A											
Refrigerant charge	kg	10,0 10,0 10,0 10,0 14,5 19,0 19,0 19,0 27,0 27,0 27,0 36,0											
Global warming potential (GWP)		2088 2088 2088 2088 2088 2088 2088 2088 2088 2088 2088 2088 2088											
Equivalent CO <sub>2</sub> charge	t	20,88 20,88 20,88 20,88 30,27 39,67 39,67 39,67 56,37 56,37 56,37 75,16											
Water tank volume	l	100 100 100 100 100 100 300 300 300 300 300 500											

HA/XL/RV - P4S	1602	1802	2002	2302	2502	2504	3004	3204	3504	4004	4504	5004 *
Heating capacity (EN14511) <sup>(1)</sup> kW	148,2	162,5	176,9	204,1	232,2	221,2	265,0	287,3	317,0	349,0	389,3	439,8
Total input power (EN14511) <sup>(1)</sup> kW	33,8	39,3	43,9	48,1	53,8	54,0	62,6	69,7	78,3	85,5	97,8	109,1
COP (EN14511) <sup>(1)</sup>	W/W	4,39	4,13	4,03	4,24	4,32	4,10	4,23	4,12	4,05	4,08	4,03
Energy Class <sup>(2)</sup>		A++	A++	A+	A++	A++	A+	A+	A+	A+	A++	A+
SCOP <sup>(2)</sup>	kWh/kWh	3,92	3,86	3,76	4,00	3,98	3,74	3,79	3,78	3,82	3,88	3,81
η <sub>s,h</sub> <sup>(2)</sup>	%	153,7	151,3	147,3	156,8	156,3	146,5	148,6	148,2	149,8	152,0	150,3
Cooling capacity (EN14511) <sup>(3)</sup> kW	124,4	139,3	152,2	174,1	187,4	190,3	223,6	245,3	275,7	306,0	353,1	381,9
Total input power (EN14511) <sup>(3)</sup> kW	44,4	52,0	59,7	67,0	78,1	73,8	80,1	91,5	106,4	120,5	135,8	155,9
EER (EN14511) <sup>(3)</sup>	W/W	2,80	2,68	2,55	2,60	2,40	2,58	2,79	2,68	2,59	2,54	2,45
TER (EN14511) <sup>(4)</sup>	W/W	9,87	9,99	9,90	9,79	9,74	9,27	9,18	9,60	9,68	9,71	9,62
Sound power <sup>(5)</sup>	dB (A)	81	81	81	83	84	81	83	84	84	84	86
Sound pressure <sup>(6)</sup>	dB (A)	49	49	49	51	52	49	51	52	52	52	55

HE/XL/RV - P4S	1602	1802	2002	2302	2502	2504	3004	3204	3504	4004	4504	5004 *	
Heating capacity (EN14511) <sup>(1)</sup> kW	147,7	162,2	175,5	202,8	230,8	220,5	264,9	287,2	317,0	348,5	396,4	441,7	
Total input power (EN14511) <sup>(1)</sup> kW	33,0	38,6	43,4	47,6	52,9	53,0	60,9	68,2	77,1	84,6	97,5	108,0	
COP (EN14511) <sup>(1)</sup>	W/W	4,48	4,20	4,04	4,26	4,36	4,16	4,35	4,21	4,11	4,12	4,14	
Energy Class <sup>(2)</sup>		A++	A++	A++	A++	A++	A++	A++	A++	A++	A++	A++	
SCOP <sup>(2)</sup>	kWh/kWh	4,06	4,01	3,85	4,10	4,06	3,84	3,97	3,92	3,96	3,97	3,91	
η <sub>s,h</sub> <sup>(2)</sup>	%	159,5	157,4	151,1	161,0	159,3	150,4	155,9	153,8	155,5	155,9	153,5	
Cooling capacity (EN14511) <sup>(3)</sup> kW	129,5	146,8	159,2	180,4	202,1	198,5	231,0	259,7	289,4	322,6	368,5	406,9	
Total input power (EN14511) <sup>(3)</sup> kW	44,1	50,8	58,8	66,2	73,3	72,7	80,5	89,2	105,2	118,2	135,0	151,3	
EER (EN14511) <sup>(3)</sup>	W/W	2,94	2,89	2,71	2,73	2,76	2,73	2,87	2,91	2,75	2,73	2,69	
TER (EN14511) <sup>(4)</sup>	W/W	9,87	9,99	9,90	9,79	9,74	9,27	9,18	9,60	9,68	9,71	9,62	
Sound power <sup>(5)</sup>	dB (A)	80	81	81	83	84	81	82	83	84	84	86	
Sound pressure <sup>(6)</sup>	dB (A)	48	49	49	51	52	49	50	51	52	52	55	
Power supply	V/Ph/Hz	400/3/50 400/3/50 400/3/50 400/3/50 400/3/50 400/3/50 400/3/50 400/3/50 400/3/50 400/3/50 400/3/50 400/3/50 400/3/50											
Compressors / Circuits	n° / n°	2 / 1 2 / 1 2 / 1 2 / 1 2 / 1 2 / 1 4 / 2 4 / 2 4 / 2 4 / 2 4 / 2 4 / 2 4 / 2											
Fans	n°	3 3 3 3 3 3 4 6 6 6 6 8 8											
Refrigerant		R410A R410A R410A R410A R410A R410A R410A R410A R410A R410A R410A R410A R410A											
Refrigerant charge	kg	36,0 36,0 45,0 45,0 60,0 60,0 72,0 72,0 72,0 90,0 90,0 100,0											
Global warming potential (GWP)		2088 2088 2088 2088 2088 2088 2088 2088 2088 2088 2088 2088 2088											
Equivalent CO <sub>2</sub> charge	t	75,16 75,16 93,96 93,96 125,28 125,28 150,33 150,33 150,33 187,92 187,92 208,80											
Water tank volume	l	500 500 500 500 500 500 1000 1000 1000 1000 1000 1000											

\* Units only available for the non-EU market

Performances are referred to the following conditions:

- (1) Heating: Ambient temperature 7°C DB, 6°C WB, water temperature 30/35°C.
- (2) Average conditions, low temperature, variable - Reg EU 811/2013
- (3) Cooling: ambient air temperature 35°C, evaporator water temperature in/out 12/7 °C.

(4) TER: Total Energy Ratio - cold circuit 12/7°C, hot circuit 30/35°C.

(5) Sound power level in accordance with ISO 3744.

(6) Sound pressure level at 10 mt from the unit in free field conditions in accordance with ISO 3744.

## Reversible heating/cooling version (RV)

HA/XL/RV - P4U	252	302	412	432	492	602	702	802	902	1002	1202	1402	
Heating capacity (EN14511) <sup>(1)</sup> kW	23,9	30,7	36,8	46,2	49,4	62,2	67,9	72,8	94,9	104,9	114,8	139,7	
Total input power (EN14511) <sup>(1)</sup> kW	5,8	7,4	8,8	11,2	11,7	13,5	15,2	16,8	21,0	24,1	27,2	30,7	
COP (EN14511) <sup>(1)</sup>	W/W	4,15	4,14	4,20	4,12	4,21	4,62	4,47	4,35	4,52	4,36	4,22	4,55
Energy Class <sup>(2)</sup>		A+	A+	A+	A+	A+	A++	A++	A++	A++	A++	A+	A++
SCOP <sup>(2)</sup>	kWh/kWh	3,45	3,65	3,68	3,65	3,77	4,11	4,06	3,99	3,96	3,94	3,80	4,03
$\eta_{s,h}$ <sup>(2)</sup>	%	134,9	142,8	144,0	143,0	147,9	161,5	159,4	156,7	155,2	154,7	148,8	158,2
Cooling capacity (EN14511) <sup>(3)</sup> kW	19,5	24,7	29,7	38,9	42,8	50,4	55,7	60,3	78,1	86,4	94,1	114,3	
Total input power (EN14511) <sup>(3)</sup> kW	7,2	9,7	11,2	15,4	16,7	19,1	22,0	25,1	26,7	31,5	36,8	39,0	
EER (EN14511) <sup>(3)</sup>	W/W	2,72	2,55	2,65	2,54	2,57	2,64	2,53	2,40	2,93	2,74	2,56	2,93
TER (EN14511) <sup>(4)</sup>	W/W	9,44	9,43	9,56	9,54	10,41	10,48	10,42	10,43	9,84	9,63	9,46	9,91
Sound power <sup>(5)</sup>	dB (A)	70	70	70	70	72	72	73	75	76	78	80	
Sound pressure <sup>(6)</sup>	dB (A)	38	38	38	38	40	40	41	43	44	46	48	
HE/XL/RV - P4U	252	302	412	432	492	602	702	802	902	1002	1202	1402	
Heating capacity (EN14511) <sup>(1)</sup> kW	23,9	30,7	36,9	46,3	49,7	62,0	67,9	72,8	94,7	104,6	113,8	139,4	
Total input power (EN14511) <sup>(1)</sup> kW	5,5	7,1	8,5	11,1	11,4	13,2	14,9	16,5	20,4	23,6	26,8	29,8	
COP (EN14511) <sup>(1)</sup>	W/W	4,39	4,29	4,34	4,16	4,35	4,71	4,55	4,40	4,64	4,44	4,25	4,68
Energy Class <sup>(2)</sup>		A+	A++	A++	A++	A++	A++	A++	A++	A++	A++	A++	A++
SCOP <sup>(2)</sup>	kWh/kWh	3,96	3,93	3,92	3,91	3,98	4,26	4,19	4,10	4,08	4,10	3,92	4,22
$\eta_{s,h}$ <sup>(2)</sup>	%	155,2	154,3	153,8	153,2	156,2	167,5	164,4	161,1	160,1	160,9	153,7	165,8
Cooling capacity (EN14511) <sup>(3)</sup> kW	19,7	25,4	30,4	39,9	44,1	52,4	57,5	63,4	80,5	90,2	100,5	117,4	
Total input power (EN14511) <sup>(3)</sup> kW	7,0	9,3	10,9	14,9	16,2	18,3	21,3	24,0	26,6	31,2	35,2	38,6	
EER (EN14511) <sup>(3)</sup>	W/W	2,83	2,73	2,78	2,67	2,72	2,87	2,70	2,65	3,03	2,89	2,86	3,04
TER (EN14511) <sup>(4)</sup>	W/W	9,44	9,43	9,56	9,54	10,41	10,48	10,42	10,43	9,84	9,63	9,46	9,91
Sound power <sup>(5)</sup>	dB (A)	68	68	68	69	72	72	73	74	76	78	79	
Sound pressure <sup>(6)</sup>	dB (A)	36	36	36	37	40	40	41	42	44	46	47	
Power supply	V/Ph/Hz	400/3+N/50	400/3+N/50	400/3/50	400/3/50	400/3/50	400/3/50	400/3/50	400/3/50	400/3/50	400/3/50	400/3/50	400/3/50
Compressors / Circuits	n° / n°	2 / 1	2 / 1	2 / 1	2 / 1	2 / 1	2 / 1	2 / 1	2 / 1	2 / 1	2 / 1	2 / 1	2 / 1
Fans	n°	2	2	2	2	2	2	2	2	2	2	2	3
Refrigerant		R410A	R410A	R410A	R410A	R410A	R410A	R410A	R410A	R410A	R410A	R410A	R410A
Refrigerant charge	kg	10,0	10,0	10,0	10,0	14,5	19,0	19,0	19,0	27,0	27,0	27,0	36,0
Global warming potential (GWP)		2088	2088	2088	2088	2088	2088	2088	2088	2088	2088	2088	2088
Equivalent CO <sub>2</sub> charge	t	20,88	20,88	20,88	20,88	30,27	39,67	39,67	39,67	56,37	56,37	56,37	75,16
Water tank volume	l	100	100	100	100	100	300	300	300	300	300	300	500

HA/XL/RV - P4U	1602	1802	2002	2302	2502	2504	3004	3204	3504	4004	4504	5004 *	
Heating capacity (EN14511) <sup>(1)</sup> kW	152,4	168,7	183,3	209,6	238,5	228,9	272,9	296,0	327,2	361,2	389,3	452,6	
Total input power (EN14511) <sup>(1)</sup> kW	34,0	38,3	43,0	48,3	53,8	55,1	64,0	69,8	78,5	86,9	97,8	111,0	
COP (EN14511) <sup>(1)</sup>	W/W	4,49	4,40	4,27	4,34	4,43	4,16	4,26	4,24	4,17	4,16	3,98	4,08
Energy Class <sup>(2)</sup>		A++	A++	A++	A++	A++	A+	A+	A++	A++	A++	A++	A++
SCOP <sup>(2)</sup>	kWh/kWh	4,00	4,02	3,94	4,08	4,10	3,76	3,80	3,90	3,92	3,89	3,85	3,85
$\eta_{s,h}$ <sup>(2)</sup>	%	157,1	157,9	154,4	160,0	160,9	147,2	149,1	152,9	153,6	152,4	151,1	150,8
Cooling capacity (EN14511) <sup>(3)</sup> kW	124,4	139,3	152,2	174,1	187,4	190,3	223,6	245,3	275,7	306,0	353,1	381,9	
Total input power (EN14511) <sup>(3)</sup> kW	44,4	52,0	59,7	67,0	78,1	73,8	80,1	91,5	106,4	120,5	135,8	155,9	
EER (EN14511) <sup>(3)</sup>	W/W	2,80	2,68	2,55	2,60	2,40	2,58	2,79	2,68	2,59	2,54	2,60	2,45
TER (EN14511) <sup>(4)</sup>	W/W	9,87	9,99	9,90	9,79	9,74	9,27	9,18	9,60	9,68	9,71	9,62	9,50
Sound power <sup>(5)</sup>	dB (A)	81	81	81	83	84	81	83	84	84	84	86	87
Sound pressure <sup>(6)</sup>	dB (A)	49	49	49	51	52	49	51	52	52	52	54	55
HE/XL/RV - P4U	1602	1802	2002	2302	2502	2504	3004	3204	3504	4004	4504	5004 *	
Heating capacity (EN14511) <sup>(1)</sup> kW	151,8	168,2	182,6	208,9	237,7	228,1	272,9	296,0	327,3	358,7	396,4	454,4	
Total input power (EN14511) <sup>(1)</sup> kW	33,2	37,6	42,4	47,8	53,1	54,3	62,3	68,4	77,4	86,1	97,5	110,1	
COP (EN14511) <sup>(1)</sup>	W/W	4,58	4,47	4,30	4,37	4,47	4,20	4,38	4,33	4,23	4,17	4,14	4,13
Energy Class <sup>(2)</sup>		A++	A++	A++	A++	A++	A++	A++	A++	A++	A++	A++	A++
SCOP <sup>(2)</sup>	kWh/kWh	4,15	4,16	4,03	4,17	4,18	3,85	3,98	4,04	4,06	3,99	3,99	3,96
$\eta_{s,h}$ <sup>(2)</sup>	%	163,0	163,4	158,2	163,9	164,0	151,1	156,3	158,5	159,2	156,4	156,6	155,3
Cooling capacity (EN14511) <sup>(3)</sup> kW	129,5	146,8	159,2	180,4	202,1	198,5	231,0	259,7	289,4	322,6	368,5	406,9	
Total input power (EN14511) <sup>(3)</sup> kW	44,1	50,8	58,8	66,2	73,3	72,7	80,5	89,2	105,2	118,2	135,0	151,3	
EER (EN14511) <sup>(3)</sup>	W/W	2,94	2,89	2,71	2,73	2,76	2,73	2,87	2,91	2,75	2,73	2,73	2,69
TER (EN14511) <sup>(4)</sup>	W/W	9,87	9,99	9,90	9,79	9,74	9,27	9,18	9,60	9,68	9,71	9,62	9,50
Sound power <sup>(5)</sup>	dB (A)	80	81	81	83	84	81	82	83	84	84	86	87
Sound pressure <sup>(6)</sup>	dB (A)	48	49	49	51	52	49	50	51	52	52	54	55
Power supply	V/Ph/Hz	400/3/50	400/3/50	400/3/50	400/3/50	400/3/50	400/3/50	400/3/50	400/3/50	400/3/50	400/3/50	400/3/50	400/3/50
Compressors / Circuits	n° / n°	2 / 1	2 / 1	2 / 1	2 / 1	2 / 1	4 / 2	4 / 2	4 / 2	4 / 2	4 / 2	4 / 2	4 / 2
Fans	n°	3	3	3	3	3	4	6	6	6	6	8	8
Refrigerant		R410A	R410A	R410A	R410A	R410A	R410A	R410A	R410A	R410A	R410A	R410A	R410A
Refrigerant charge	kg	36,0	36,0	45,0	45,0	60,0	60,0	72,0	72,0	90,0	90,0	100,0	100,0
Global warming potential (GWP)		2088	2088	2088	2088	2088	2088	2088	2088	2088	2088	2088	2088
Equivalent CO <sub>2</sub> charge	t	75,16	75,16	93,96	93,96	125,28	125,28	150,33	150,33	187,92	187,92	208,80	208,80
Water tank volume	l	500	500	500	500	500	1000	1000	1000	1000	1000	1000	1000

\* Units only available for the non-EU market

Performances are referred to the following conditions:  
(1) Heating: Ambient temperature 7°C DB, 6°C WB, water temperature 30/35°C.  
(2) Average conditions, low temperature, variable - Reg EU 811/2013  
(3) Cooling: ambient air temperature 35°C, evaporator water temperature in/out 12/7 °C.

(4) TER: Total Energy Ratio - cold circuit 12/7°C, hot circuit 30/35°C.

(5) Sound power level in accordance with ISO 3744.

(6) Sound pressure level at 10 mt from the unit in free field conditions in accordance with ISO 3744.

## COMPONENTS

### FRAME

All units are made from hot-galvanised sheet steel, painted with polyurethane powder enamel and stoved at 180°C to provide maximum protection against corrosion. The frame is self-supporting with removable panels. All screws and rivets used are made from stainless steel. The standard colour of the units is RAL9018.

### REFRIGERANT CIRCUIT

The refrigerant utilised is R410A. The refrigerant circuit is assembled using internationally recognised brand name components with all brazing and welding being performed in accordance with ISO 97/23. The refrigerant circuit includes: sight glass, filter drier, two thermal expansion valves (one for cooling mode, one for heating mode) with external equalizer, 4 way reversing valve, check valves, liquid receiver, Schrader valves for maintenance and control, pressure safety device (for compliance with PED regulations).

### COMPRESSORS

The compressors used are a high performance scroll type that incorporates a special scroll design which enhances the efficiency of the refrigerant cycle when the source temperature is low. In all units the compressors are connected in tandem.

The compressors are all supplied with a crankcase heater and thermal overload protection by a klixon embedded in the motor winding. They are mounted in a separate enclosure in order to be separated from the air stream thus enabling them to be maintained even if the unit is operating. Access to this enclosure is by the front panel of the unit. The crankcase heater is always powered when the compressor is in stand-by.

### SOURCE HEAT EXCHANGER

The source heat exchanger is made from copper pipes and aluminium fins. Dimensioning of the copper pipes and the aluminium wings is optimized in order to obtain excellent performance. The tubes are mechanically expanded into the fins in order to maximise heat transfer. Furthermore, the design guarantees a low air side pressure drop thus enabling the use of low rotation speed (and hence low noise) fans. All heat exchangers are supplied standard with fins hydrophilic coating.

### USER HEAT EXCHANGERS

The user heat exchanger is a braze welded, plate type heat exchanger, manufactured from AISI 316 stainless steel.

The use of this type of exchanger results in a massive reduction of the refrigerant charge of the unit compared to a traditional shell-in-tube type. A further advantage is a reduction in the overall dimensions of the unit.

The exchangers are factory insulated with flexible close cell material and can be fitted with an antifreeze heater (accessory). Each exchanger is fitted with a temperature sensor on the discharge water side for antifreeze protection.

### FANS

The fans are direct drive axial type with aluminium aerofoil blades, are statically and dynamically balanced and are supplied complete with a safety fan guard complying with the requirements of EN 60335.

They are fixed to the unit frame via rubber anti-vibration mountings. The electric motors, in LS versions are 6 poles type rotating at approximately 900 rpm. In the XL versions the fans are 8 poles

type (approx 600 rpm). The motors are fitted with integrated thermal overload protection and have a moisture protection rating of IP 54.

### MICROPROCESSORS

All units are supplied as standard complete with control panel. The microprocessor controls the following functions: control of the water temperature, antifreeze protection, compressor timing, compressor automatic starting sequence (For multiple compressors), alarm reset.

The control panel is supplied with display showing all operational icons. The microprocessor is set for automatic defrost (when operating in severe ambient conditions) and for summer/ winter change over (only for RV versions).

The control also manages the anti-legionella program, the integration with other heating sources (electric heaters, boilers, solar panels etc), the operation of a three port modulating valve (for diverting to DHW or heating) and both the heating circuit pump and the domestic hot water circuit pump. If required (available as an option), the microprocessor can be configured in order for it to connect to a site BMS system thus enabling remote control and management.

### ELECTRIC ENCLOSURE

The enclosure is manufactured in order to comply with the requirements of the electromagnetic compatibility standards CEE EN60204. Access to electrical cabinet in quick and easy thanks to hinged panels. The following components are supplied as standard on all units: main switch, a sequence relay that disables the power supply in the event that the phase sequence is incorrect (scroll compressors can be damaged if they rotate in the wrong direction), thermal overloads (protection of pumps and fans), compressor fuses, control circuit automatic breakers, compressor contactors, fan contactors and pump contactors. The terminal board has volt free contacts for remote ON-OFF, Summer/ winter change over (heat pumps only) and general alarm.

### CONTROL AND PROTECTION DEVICES

All units are supplied with the following controls and protections: user water return temperature sensor, antifreeze protection temperature sensor installed on users water output, domestic hot water supply and return temperature sensors, high pressure manual reset, low pressure automatic reset, compressor thermal protection, air fan, thermal protection, pressure transducer (used to optimize the defrost cycle and to adjust the fan speed depending on ambient conditions), flow switch.

All units in HA and HE versions are also fitted with a temperature probe sensor with "Energy Saving" function, supplied in a separate plastic box, which can be used to stop the pump use during periods of stand-by, when the water temperature reaches the set point. Doing this the power consumption of the unit is strongly reduced. The probe sensor must be positioned in the hydraulic compensator present at the screening technique.

The domestic hot water circuit (only versions P2S) is already equipped with this probe, but it must be installed in the user circuit.

## VERSIONS

### P4U version

The P4U units use 4 hydraulic connections and are used in modern 4-pipe systems. In these systems, cold and hot water is always available (in every period of the year) and present in the specific hydraulic circuit.

These systems allow the simultaneous production of cold water and hot water using 4 hydraulic connections, 2 connections are related to the hot water circuit, 2 connections are related to the cold water circuit.

The plant thus conceived is able to heat and, at the same time, if required, to cool with very high energy efficiencies. In this configuration, however, the units are also able to produce hot or cold water separately at any time of the year.

The units are supplied with 2 heat exchangers, one dedicated to the production of cold water and one dedicated to the production of hot water.

The operating modes are:

**1. User water heating:** The unit behaves like a normal air/water heat pump in heating mode, using the finned heat exchanger as the source and the A plate heat exchanger as user.

**2. User water cooling:** The unit behaves like a normal air / water chiller in cooling mode, using the finned exchanger as the source and the B plate heat exchanger as user.

**3. Simultaneous user Cooling + heating:** The unit behaves like a water / water heat pump, using the plate heat exchanger B as the cold user and the plate heat exchanger A as hot user. This version is not able to produce domestic hot water.

### P4S Version

The P4S units have been designed to meet the needs of 2 + 2 pipe systems (2 user side pipes, 2 domestic hot water pipes) throughout the year. The units are supplied with 2 exchangers, one dedicated to the production of the user cold and hot water and one dedicated to the production of domestic hot water only (D.H.W.). The production of domestic hot water always has priority. In winter mode the activation of D.H.W. production temporarily stops the production of the user hot water, which is restored when the D.H.W. accumulation reaches the temperature set. In summer mode the unit will switch to cooling (by activating the reverse cycle valve installed in the refrigerant circuit) and any request for domestic hot water will allow, at the same time, the production of cold water. In this operating mode, the system can simultaneously produce cold water and domestic hot water. Domestic hot water, in summer mode, is produced by heat recovery and therefore free of charge. When the temperature measured by the D.H.W. sensor reaches the set, the D.H.W. water pump is stopped and normal operation is restored in cooling mode.

The operating modes are:

## P4U VERSION

User water heating

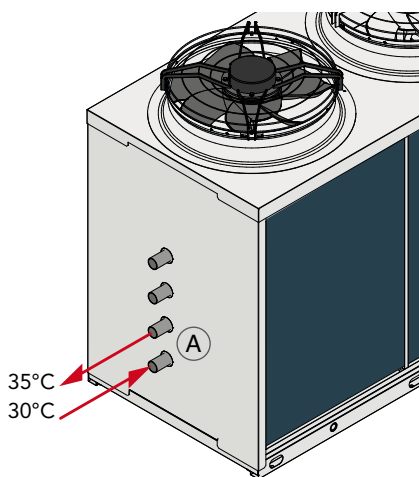

User water cooling

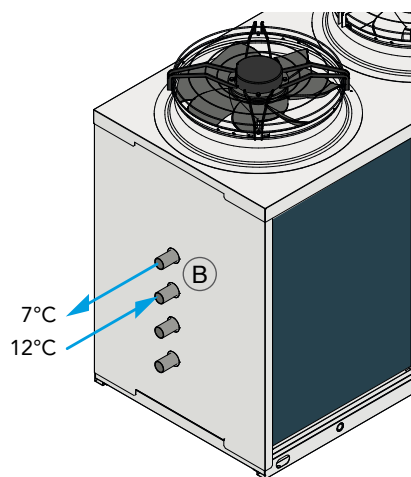

Simultaneous user Cooling + heating

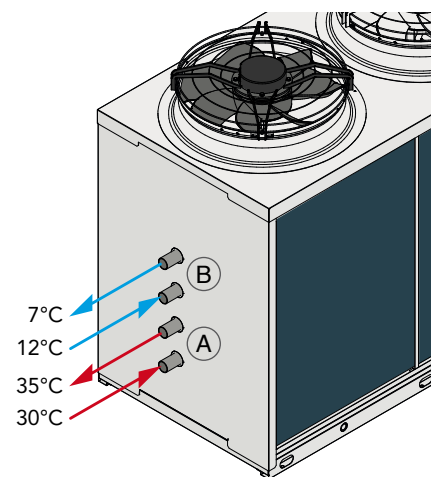

The above scheme is for illustrative purposes only. For the correct pipes placement, please refer to the units technical manual.



**1. User water heating:** The unit behaves like a normal air/water heat pump in heating mode, using the finned heat exchanger as the source and the A plate heat exchanger as user.

**2. User water cooling:** The unit behaves like a normal air/water chiller in cooling mode, using the finned heat exchanger as the source and the A plate heat exchanger as user.

**3. Domestic hot water production (D.H.W.):** The unit behaves like a normal air / water heat pump in heating mode, using the finned heat exchanger as the source and as a user the plate heat exchanger B (a special D.H.W. heat exchanger that works with a higher set point).

**4. User water cooling + D.H.W. production:** The unit behaves like a water / water heat pump, using the plate heat exchanger A as the cold user and the plate heat exchanger B as D.H.W. production).

**SA Version**

Standard efficiency version, according to current standard. Unit equipped with AC fans.

**SE Version**

Standard efficiency version, according to current standard. Unit equipped with EC fans.

**HA Version**

High efficiency version, according to current standard. Unit equipped with AC fans.

**HE Version**

High efficiency version, according to current standard. Unit equipped with EC fans.

**Version LS**

This version includes the complete acoustic insulation of the unit with compressor jackets and insulating material made with high density media and the interposition of heavy bitumen layer.

**P4S VERSION**

User water heating

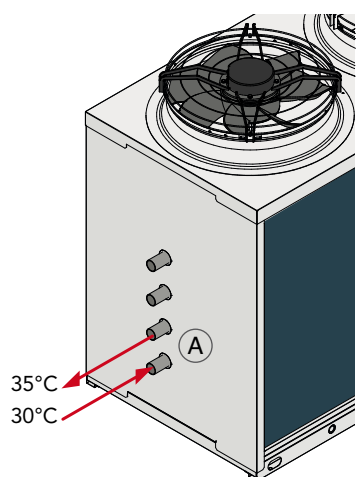

User water cooling

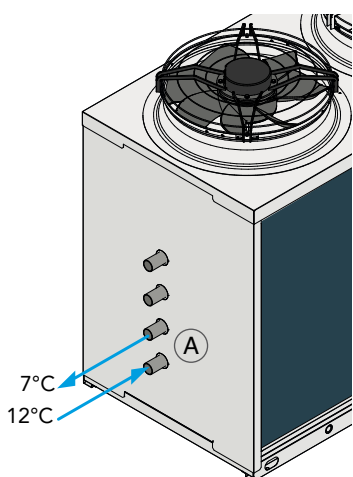

Domestic hot water production (D.H.W.)

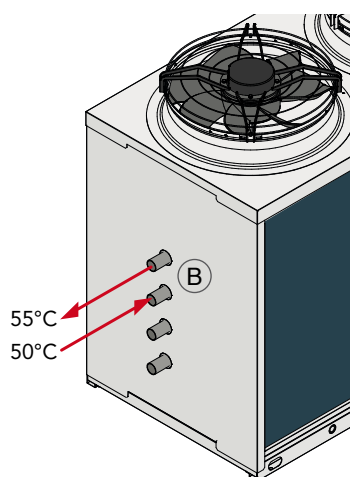

User water cooling + D.H.W. production

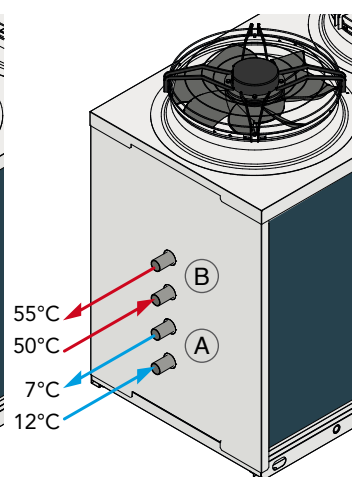

The above scheme is for illustrative purposes only. For the correct pipes placement, please refer to the units technical manual.

**XL Super low noise version**

All units in XL super low noise version are supplied, as standard, with the latest 'Floating Frame' technology that completely isolates the compressors from the main casing, thereby eliminating vibration and noise from this source. The 'Floating Frame' is a special vibration and acoustic damping system that consists of a base plate and acoustic enclosure that houses the compressors. The base plate is separated from the supporting frame of the unit by soft steel springs that have a high damping power. Within the enclosure, the compressors are mounted on rubber shock absorbers on the floating base plate. The enclosure is manufactured from galvanized steel sandwich panels that have a micro-perforated inner skin and a core of 30 mm thick, high density (25 kg/m<sup>3</sup>). The entire arrangement provides a double damping system and acoustic attenuation. The compressor refrigerant pipes are connected to the refrigerant circuit through "anaconda" flexible connections. Flexible connections are also used on the water pipework within the unit. The combination of these systems results in an overall noise reduction in the region of 6-8 dB(A).

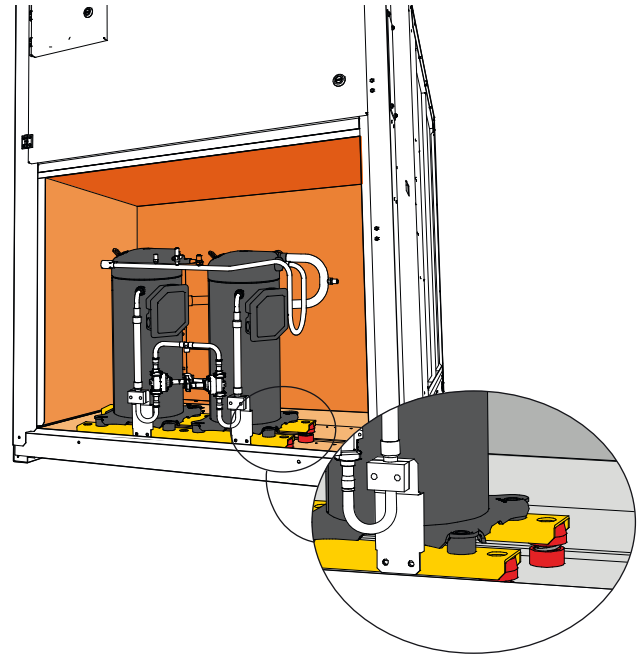

**OPERATION LIMITS**

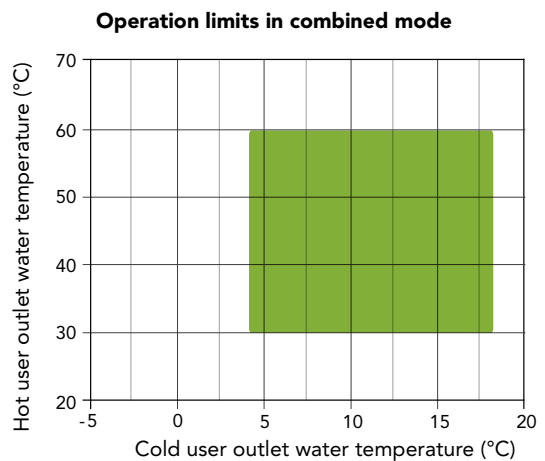
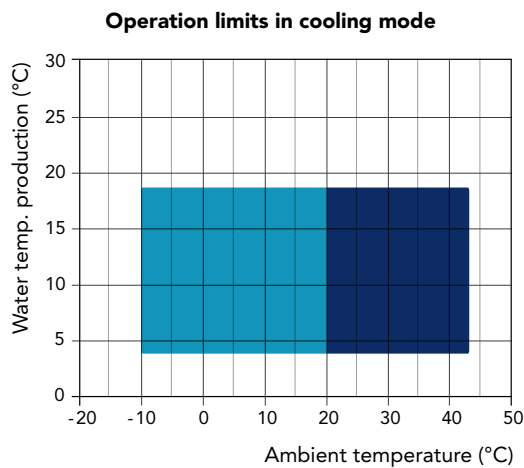
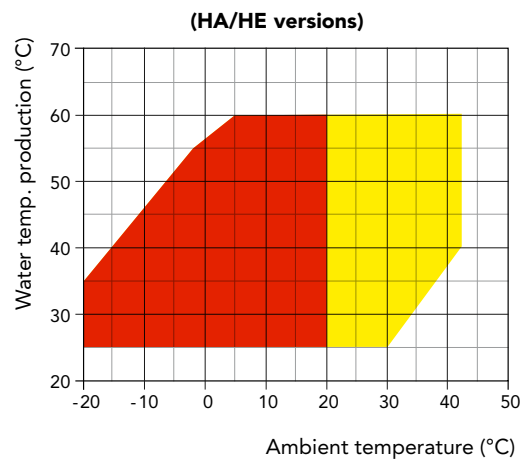
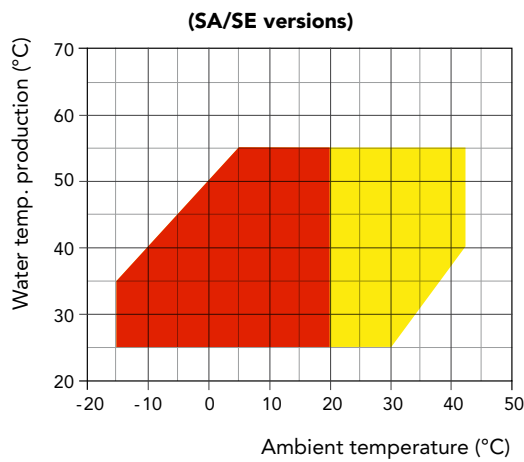

- Heating mode
- Heating mode with head pressure control (DCCF)
- Cooling with head pressure control (DCCF)
- Cooling mode
- Combined mode

# ACCESSORIES

LHA/P4

LHA SA-SE/HH-RV	LHA HA-HE/HH-RV	P4S/P4U	242 252	292 302	402	412	432	492	592	602	702	802
Flow switch			●	●	●	●	●	●	●	●	●	●
"Floating frame" Technology - LS Version			-	-	-	-	-	-	-	-	-	-
"Floating frame" Technology - XL Version			●	●	●	●	●	●	●	●	●	●
E.C. fans - SA versions	VECE		-	-	-	-	-	-	-	-	-	-
E.C. fans - SE versions	VECE		●	●	●	●	●	●	●	●	●	●
E.C. fans - HA versions	VECE		-	-	-	-	-	-	-	-	-	-
E.C. fans - HE versions	VECE		●	●	●	●	●	●	●	●	●	●
Condensate discharge drip tray with antifreeze heater	BRCA		○	○	○	○	○	○	○	○	○	○
Fans regulation by phase cut	DCCF		●	●	●	●	●	●	●	●	●	●
Antifreeze kit for 4 pipe units	RAEV4		○	○	○	○	○	○	○	○	○	○
Electronic soft starter	DSSE		○	○	○	○	○	○	○	○	○	○
Serial interface card RS485	INSE		●	●	●	●	●	●	●	●	●	●
Rubber anti-vibration mountings	KAVG		○	○	○	○	○	○	○	○	○	○
Remote control panel	PCRL		○	○	○	○	○	○	○	○	○	○
Electronic expansion valve	VTEE		○	○	○	○	○	○	○	○	○	○
Cascade control system via RS485	SGRS		○	○	○	○	○	○	○	○	○	○
Hydraulic kit with one pump with tank	A1ZZU		○	○	○	○	○	○	○	○	○	○
Hydraulic kit with two pumps with tank	A2ZZU		○	○	○	○	○	○	○	○	○	○
Hydraulic kit with one pump without tank	A1NTU		○	○	○	○	○	○	○	○	○	○
Hydraulic kit with two pumps without tank	A2NTU		○	○	○	○	○	○	○	○	○	○
Hydraulic kit with 1 pump - recovery circuit	A1NTR		○	○	○	○	○	○	○	○	○	○
Hydraulic kit with 2 pumps - recovery circuit	A2NTR		○	○	○	○	○	○	○	○	○	○

● Standard ○ Optional - Not available

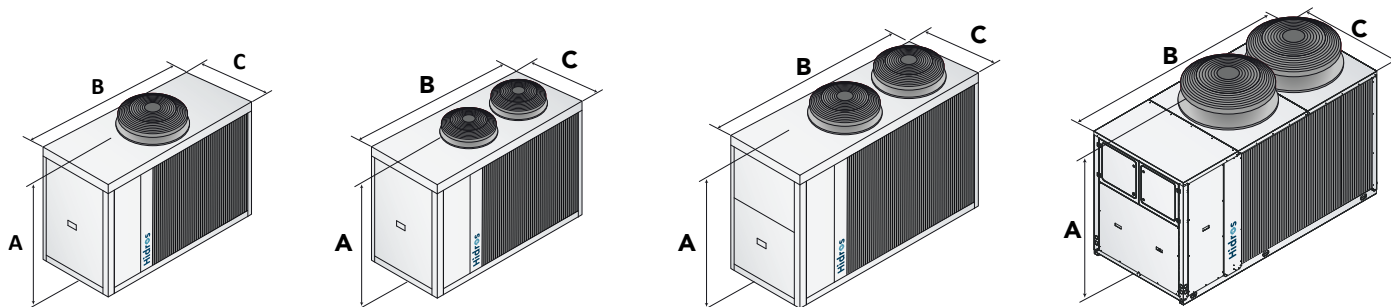

**SA/SE 242 - 292**  
**HA/HE LS 242 - 292**

**SA/SE 402**  
**HA/HE XL 252 - 302**

**SA/SE 432 - 492 - 592**  
**HA/HE-LS/XL 412 - 432 - 492**

**SA/SE 702 - 802 - 902**  
**HA/HE-LS/XL 602 - 702 - 802 - 902 - 1002 - 1202**

		242/252	292/302	402	412	432	492	592	602	702	802
A (mm)	<b>SA-SE/LS</b>	1500	1500	1500	--	1690	1690	1690	--	1880	1880
B (mm)	<b>SA-SE/LS</b>	1915	1915	1915	--	2400	2400	2400	--	2905	2905
C (mm)	<b>SA-SE/LS</b>	875	875	875	--	1150	1150	1150	--	1145	1150
kg	<b>SA-SE/LS</b>	550	550	560	--	670	700	760	--	880	890
A (mm)	<b>HA-HE/LS</b>	1500	1500	--	1690	1690	1690	--	1880	1890	1880
B (mm)	<b>HA-HE/LS</b>	1915	1915	--	2400	2400	2400	--	2905	2905	2905
C (mm)	<b>HA-HE/LS</b>	875	875	--	1150	1150	1150	--	1150	1150	1150
kg	<b>HA-HE/LS</b>	560	560	--	670	690	720	--	1060	1060	1070
A (mm)	<b>HA-HE/XL</b>	1500	1500	--	1690	1690	1690	--	1880	1880	1880
B (mm)	<b>HA-HE/XL</b>	1915	1915	--	2400	2400	2400	--	2905	2905	2905
C (mm)	<b>HA-HE/XL</b>	875	875	--	1150	1150	1150	--	1150	1150	1150
kg	<b>HA-HE/XL</b>	570	570	--	680	710	740	--	1080	1080	1090

LHA SA-SE/HH-RV	LHA HA-HE/HH-RV	P4S/P4U	902	1002	1202	1402	1602	1802	2002	2302
Flow switch			●	●	●	●	●	●	●	●
"Floating frame" Technology - LS Version			-	-	-	-	-	-	-	-
"Floating frame" Technology - XL Version			●	●	●	●	●	●	●	●
E.C. fans - SA versions	VECE		-	-	-	-	-	-	-	-
E.C. fans - SE versions	VECE		●	●	●	●	●	●	●	●
E.C. fans - HA versions	VECE		-	-	-	-	-	-	-	-
E.C. fans - HE versions	VECE		●	●	●	●	●	●	●	●
Condensate discharge drip tray with antifreeze heater	BRCA		○	○	○	○	○	○	○	○
Fans regulation by phase cut	DCCF		●	●	●	●	●	●	●	●
Antifreeze kit for 4 pipe units	RAEV4		○	○	○	○	○	○	○	○
Electronic soft starter	DSSE		○	○	○	○	○	○	○	○
Serial interface card RS485	INSE		●	●	●	●	●	●	●	●
Rubber anti-vibration mountings	KAVG		○	○	○	○	○	○	○	○
Remote control panel	PCRL		○	○	○	○	○	○	○	○
Electronic expansion valve	VTEE		○	○	○	○	○	○	○	○
Cascade control system via RS485	SGRS		○	○	○	○	○	○	○	○
Hydraulic kit with one pump with tank	A1ZZU		○	○	○	○	○	○	○	○
Hydraulic kit with two pumps with tank	A2ZZU		○	○	○	○	○	○	○	○
Hydraulic kit with one pump without tank	A1NTU		○	○	○	○	○	○	○	○
Hydraulic kit with two pumps without tank	A2NTU		○	○	○	○	○	○	○	○
Hydraulic kit with 1 pump - recovery circuit	A1NTR		○	○	○	○	○	○	○	○
Hydraulic kit with 2 pumps - recovery circuit	A2NTR		○	○	○	○	○	○	○	○

● Standard ○ Optional - Not available

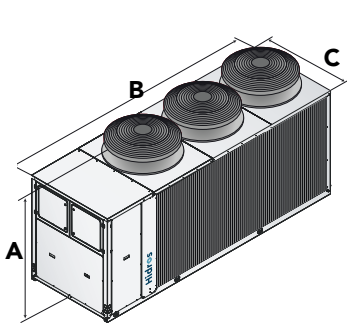

SA/SE 1002 - 1202 - 1402 - 1602  
HA/HE-LS/XL 1402 - 1602 - 1802 - 2002

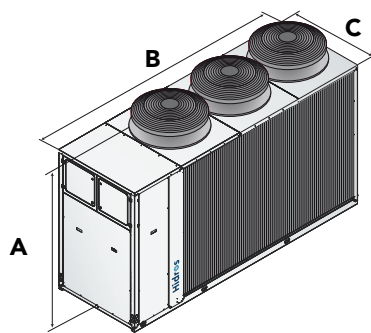

SA/SE 1802 - 2002  
HA/HE-LS/XL 2302 - 2502

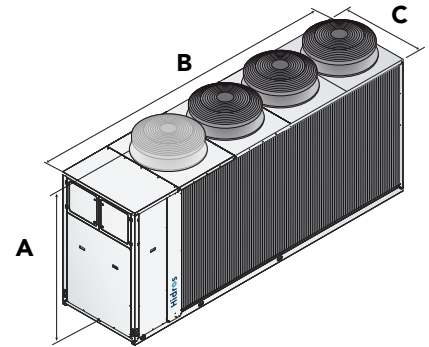

SA/SE 2302 - 2502

		902	1002	1202	1402	1602	1802	2002	2302
A (mm)	SA-SE/LS	1880	1880	1880	1880	1880	2270	2270	2310
B (mm)	SA-SE/LS	2905	3905	3905	3905	3905	3905	3905	4505
C (mm)	SA-SE/LS	1150	1150	1150	1150	1150	1150	1150	1150
kg	SA-SE/LS	910	1190	1270	1320	1360	1690	1710	1990
A (mm)	HA-HE/LS	1880	1880	1880	1880	1880	1880	1880	2280
B (mm)	HA-HE/LS	2905	2905	2905	3905	3905	3905	3905	3905
C (mm)	HA-HE/LS	1150	1150	1150	1150	1150	1150	1150	1150
kg	HA-HE/LS	1120	1160	1240	1560	1580	1600	1620	1790
A (mm)	HA-HE/XL	1880	1880	1880	1880	1880	1880	1880	2280
B (mm)	HA-HE/XL	2905	2905	2905	3905	3905	3905	3905	3905
C (mm)	HA-HE/XL	1150	1150	1150	1150	1150	1150	1150	1150
kg	HA-HE/XL	1140	1180	1260	1590	1610	1630	1650	1820

LHA SA-SE/HH-RV	LHA HA-HE/HH-RV	P4S/P4U	2502	2504	3004	3204	3504	4004	4504	5004
Flow switch			●	●	●	●	●	●	●	●
"Floating frame" Technology - LS Version			-	-	-	-	-	-	-	-
"Floating frame" Technology - XL Version			●	●	●	●	●	●	●	●
E.C. fans - SA versions	VECE		-	-	-	-	-	-	-	-
E.C. fans - SE versions	VECE		●	●	●	●	●	●	●	●
E.C. fans - HA versions	VECE		-	-	-	-	-	-	-	-
E.C. fans - HE versions	VECE		●	●	●	●	●	●	●	●
Condensate discharge drip tray with antifreeze heater	BRCA		○	○	○	○	○	○	○	○
Fans regulation by phase cut	DCCF		●	●	●	●	●	●	●	●
Antifreeze kit for 4 pipe units	RAEV4		○	○	○	○	○	○	○	○
Electronic soft starter	DSSE		○	○	○	○	○	○	○	○
Serial interface card RS485	INSE		●	●	●	●	●	●	●	●
Rubber anti-vibration mountings	KAVG		○	○	○	○	○	○	○	○
Remote control panel	PCRL		○	○	○	○	○	○	○	○
Electronic expansion valve	VTEE		○	○	○	○	○	○	○	○
Cascade control system via RS485	SGRS		○	○	○	○	○	○	○	○
Hydraulic kit with one pump with tank	A1ZZU		○	○	○	○	○	○	○	○
Hydraulic kit with two pumps with tank	A2ZZU		○	○	○	○	○	○	○	○
Hydraulic kit with one pump without tank	A1NTU		○	○	○	○	○	○	○	○
Hydraulic kit with two pumps without tank	A2NTU		○	○	○	○	○	○	○	○
Hydraulic kit with 1 pump - recovery circuit	A1NTR		○	○	○	○	○	○	○	○
Hydraulic kit with 2 pumps - recovery circuit	A2NTR		○	○	○	○	○	○	○	○

● Standard ○ Optional - Not available

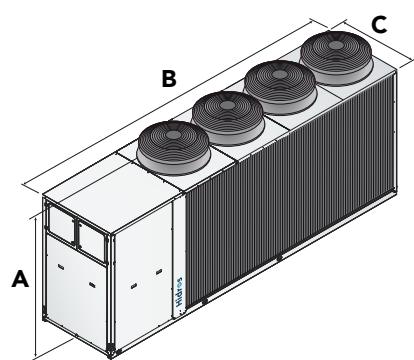

SA/SE 2504 - 3004 - 3204

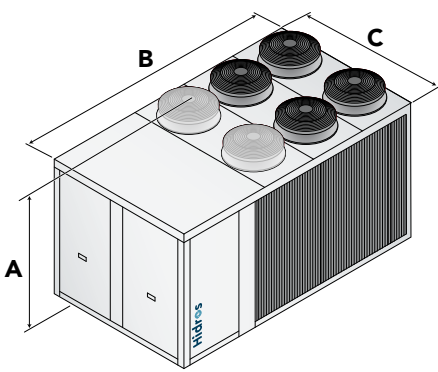

SA/SE 3504 - 4004  
HA/HE-LS/XL 2504 - 3004 - 3204 - 3504

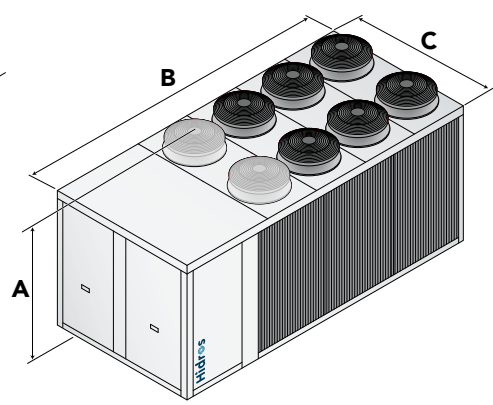

SA/SE 4504 - 5004  
HA/HE-LS/XL 4004 - 4504 - 5004

		2502	2504	3004	3204	3504	4004	4504	5004
A (mm)	SA-SE/LS	2310	2310	2310	2310	2350	2350	2380	2380
B (mm)	SA-SE/LS	4505	5300	5300	5300	4205	4205	4810	4810
C (mm)	SA-SE/LS	1150	1150	1150	1150	2210	2210	2210	2210
kg	SA-SE/LS	2040	2500	2540	2620	3220	3270	3600	3700
A (mm)	HA-HE/LS	2280	2350	2350	2350	2350	2380	2380	2380
B (mm)	HA-HE/LS	3905	4205	4205	4205	4205	4805	4810	4810
C (mm)	HA-HE/LS	1150	2210	2210	2210	2210	2210	2210	2210
kg	HA-HE/LS	1820	3170	3220	3270	3320	3660	3720	3780
A (mm)	HA-HE/XL	2280	2350	2350	2350	2350	2380	2380	2380
B (mm)	HA-HE/XL	3905	4205	4205	4205	4205	4805	4810	4810
C (mm)	HA-HE/XL	1150	2210	2210	2210	2210	2210	2210	2210
kg	HA-HE/XL	1850	3220	3270	3320	3370	3710	3770	3830

# LHE/P4

## HIGH EFFICIENCY AIR TO WATER HEAT PUMPS WITH LOW GWP REFRIGERANT

Heating power from 45 kW to 454 kW

R454B

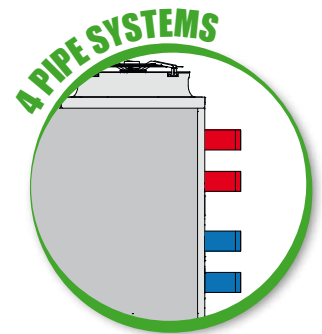
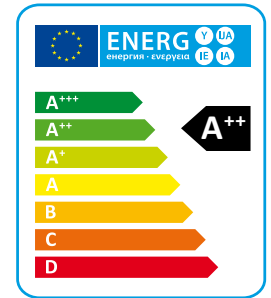

LHE high-efficiency air/water heat pumps are particularly suitable for applications where maximum efficiency in heating mode and a low noise level are required. The units are specifically designed to provide the best efficiency in heating mode; they can operate at outside temperatures down to -20°C and produce water up to a temperature of 60°C.

All sizes are supplied with reverse cycle valve used for winter defrost; the RV versions are also able to produce cold water in summer period (not available for HH versions).

### VERSIONS

- RV** Reversible heating/cooling.
- HA** High efficiency, AC fans.
- HE** High efficiency, EC fans.
- LS** Low noise.
- XL** Super low noise.
- P4U** 4 pipe systems heating/cooling.
- P4S** 2+2 pipe systems with D.H.W. production.

## TECHNICAL DATA

### Reversible heating/cooling version (RV)

<b>HA/LS/RV P4U</b>		<b>452</b>	<b>512</b>	<b>682</b>	<b>752</b>	<b>912</b>	<b>1102</b>	<b>1152</b>	<b>1352</b>	<b>1502</b>	<b>1612</b>
Heating capacity (EN14511) <sup>(1)</sup>	kW	45,6	51,8	69,0	75,0	92,0	104,0	115,0	136,0	152,0	163,0
Total input power (EN14511) <sup>(1)</sup>	kW	11,2	12,5	15,6	17,6	21,7	24,5	27,0	32,1	36,6	38,8
COP (EN14511) <sup>(1)</sup>	W/W	4,07	4,14	4,42	4,26	4,24	4,24	4,26	4,24	4,15	4,20
Energy Class <sup>(2)</sup>		A+	A++	A++	A++	A+	A++	A++	A+	A+	A++
SCOP <sup>(2)</sup>	kWh/kWh	3,80	3,90	4,20	4,10	3,70	4,00	4,00	3,80	3,80	3,90
$\eta_{s,h}$ <sup>(2)</sup>	%	149	153	165	161	145	157	157	149	149	153
Cooling capacity (EN14511) <sup>(3)</sup>	kW	37,7	43,2	57,1	61,0	76,7	86,9	96,0	112,0	125,0	136,0
Total input power (EN14511) <sup>(3)</sup>	kW	14,0	16,4	21,3	24,6	26,5	30,3	35,0	38,3	44,3	48,5
EER (EN14511) <sup>(3)</sup>	W/W	2,69	2,63	2,68	2,48	2,89	2,87	2,74	2,92	2,82	2,80
TER (EN14511) <sup>(4)</sup>	W/W	9,61	9,84	10,2	9,82	10,1	9,91	10,1	9,86	9,57	9,80
Sound power <sup>(5)</sup>	dB (A)	77	76	77	78	82	83	85	86	87	87
Sound pressure <sup>(6)</sup>	dB (A)	46	44	45	46	50	51	53	54	55	55
<b>HE/LS/RV P4U</b>		<b>452</b>	<b>512</b>	<b>682</b>	<b>752</b>	<b>912</b>	<b>1102</b>	<b>1152</b>	<b>1352</b>	<b>1502</b>	<b>1612</b>
Heating capacity (EN14511) <sup>(1)</sup>	kW	45,2	51,8	69,2	75,4	91,6	103,0	114,0	135,0	151,0	163,0
Total input power (EN14511) <sup>(1)</sup>	kW	10,7	12,5	15,6	17,6	20,5	23,5	25,9	30,2	34,8	37,1
COP (EN14511) <sup>(1)</sup>	W/W	4,22	4,14	4,44	4,28	4,47	4,38	4,40	4,47	4,34	4,39
Energy Class <sup>(2)</sup>		A++	A++	A++	A++	A++	A++	A++	A++	A++	A++
SCOP <sup>(2)</sup>	kWh/kWh	4,10	4,00	4,20	4,30	4,10	4,30	4,30	4,20	4,20	4,10
$\eta_{s,h}$ <sup>(2)</sup>	%	161	157	165	169	161	169	169	165	165	161
Cooling capacity (EN14511) <sup>(3)</sup>	kW	36,9	43,2	57,6	61,5	76,5	85,5	95,0	112,0	124,0	134,0
Total input power (EN14511) <sup>(3)</sup>	kW	14,1	16,5	21,2	24,5	25,8	30,3	34,6	37,3	43,6	48,1
EER (EN14511) <sup>(3)</sup>	W/W	2,62	2,62	2,72	2,51	2,97	2,82	2,75	3,00	2,84	2,79
TER (EN14511) <sup>(4)</sup>	W/W	9,61	9,84	10,2	9,82	10,1	9,91	10,1	9,86	9,57	9,80
Sound power <sup>(5)</sup>	dB (A)	78	79	81	82	86	87	88	89	89	90
Sound pressure <sup>(6)</sup>	dB (A)	46	47	49	50	54	55	56	57	56	57
Power supply	V/Ph/Hz	400/3/50	400/3/50	400/3/50	400/3/50	400/3/50	400/3/50	400/3/50	400/3/50	400/3/50	400/3/50
Compressors / Circuits	n° / n°	2 / 1	2 / 1	2 / 1	2 / 1	2 / 1	2 / 1	2 / 1	2 / 1	2 / 1	2 / 1
Fans	n°	2	2	2	2	2	2	2	3	3	3
Refrigerant		R454B	R454B	R454B	R454B	R454B	R454B	R454B	R454B	R454B	R454B
Refrigerant charge	kg	10,0	14,5	19,0	19,0	27,0	27,0	27,0	36,0	36,0	36,0
Global warming potential (GWP)		466	466	466	466	466	466	466	466	466	466
Equivalent CO <sub>2</sub> charge	t	4,7	6,8	8,9	8,9	12,6	12,6	12,6	16,8	16,8	16,8
Water tank volume	l	140	140	300	300	300	300	300	500	500	500
<b>HA/LS/RV P4U</b>		<b>1792</b>	<b>2012</b>	<b>2304</b>	<b>2312</b>	<b>2654</b>	<b>2954</b>	<b>3214</b>	<b>3514</b>	<b>3954</b>	<b>4454</b>
Heating capacity (EN14511) <sup>(1)</sup>	kW	185,0	205,0	234,0	234,0	273,0	305,0	328,0	373,0	415,0	464,0
Total input power (EN14511) <sup>(1)</sup>	kW	43,7	48,1	54,8	53,6	65,8	75,1	80,0	91,0	101,0	112,0
COP (EN14511) <sup>(1)</sup>	W/W	4,23	4,26	4,27	4,37	4,15	4,06	4,10	4,10	4,11	4,14
Energy Class <sup>(2)</sup>		A++	A++	A+	A++	A+	A+	A+	A+	A+	A+
SCOP <sup>(2)</sup>	kWh/kWh	4,10	4,10	3,80	4,20	3,60	3,60	3,80	3,70	3,70	3,70
$\eta_{s,h}$ <sup>(2)</sup>	%	161	161	149	165	141	141	149	145	145	145
Cooling capacity (EN14511) <sup>(3)</sup>	kW	160,0	175,0	197,0	195,0	229,0	254,0	271,0	306,0	352,0	387,0
Total input power (EN14511) <sup>(3)</sup>	kW	57,0	62,8	70,3	69,4	78,3	91,9	100,0	116,0	125,0	141,0
EER (EN14511) <sup>(3)</sup>	W/W	2,81	2,79	2,80	2,81	2,92	2,76	2,71	2,64	2,82	2,74
TER (EN14511) <sup>(4)</sup>	W/W	10,3	10,1	10,1	10,0	9,81	9,52	9,58	9,48	9,82	9,78
Sound power <sup>(5)</sup>	dB (A)	89	89	88	91	89	90	90	92	92	94
Sound pressure <sup>(6)</sup>	dB (A)	57	57	56	58	56	58	58	60	59	62
<b>HE/LS/RV P4U</b>		<b>1792</b>	<b>2012</b>	<b>2304</b>	<b>2312</b>	<b>2654</b>	<b>2954</b>	<b>3214</b>	<b>3514</b>	<b>3954</b>	<b>4454</b>
Heating capacity (EN14511) <sup>(1)</sup>	kW	184,0	204,0	233,0	231,0	272,0	304,0	326,0	371,0	413,0	461,0
Total input power (EN14511) <sup>(1)</sup>	kW	42,1	46,4	52,5	51,8	62,0	71,4	76,5	87,8	96,7	108,0
COP (EN14511) <sup>(1)</sup>	W/W	4,37	4,40	4,44	4,46	4,39	4,26	4,26	4,23	4,27	4,27
Energy Class <sup>(2)</sup>		A++	A++	A++	A++	A++	A++	A++	A++	A++	A++
SCOP <sup>(2)</sup>	kWh/kWh	4,40	4,40	4,30	4,40	4,00	4,20	4,20	4,20	4,20	4,10
$\eta_{s,h}$ <sup>(2)</sup>	%	173	173	169	173	157	165	165	165	165	161
Cooling capacity (EN14511) <sup>(3)</sup>	kW	158,0	173,0	194	192,0	227,0	252,0	269,0	304,0	349,0	384,0
Total input power (EN14511) <sup>(3)</sup>	kW	56,9	62,7	69,8	69,7	76,8	90,4	99,0	115,0	124,0	140,0
EER (EN14511) <sup>(3)</sup>	W/W	2,78	2,76	2,78	2,75	2,96	2,79	2,72	2,64	2,81	2,74
TER (EN14511) <sup>(4)</sup>	W/W	10,3	10,1	10,1	10,0	9,81	9,52	9,58	9,48	9,82	9,78
Sound power <sup>(5)</sup>	dB (A)	90	92	91	92	91	92	92	93	91	89
Sound pressure <sup>(6)</sup>	dB (A)	58	59	58	60	58	59	59	60	59	56
Power supply	V/Ph/Hz	400/3/50	400/3/50	400/3/50	400/3/50	400/3/50	400/3/50	400/3/50	400/3/50	400/3/50	400/3/50
Compressors / Circuits	n° / n°	2 / 1	2 / 1	4 / 2	2 / 1	4 / 2	4 / 2	4 / 2	4 / 2	4 / 2	4 / 2
Fans	n°	3	3	4	3	6	6	6	6	8	8
Refrigerant		R454B	R454B	R454B	R454B	R454B	R454B	R454B	R454B	R454B	R454B
Refrigerant charge	kg	45,0	45,0	60,0	60,0	72,0	72,0	72,0	72,0	90,0	100,0
Global warming potential (GWP)		466	466	466	466	466	466	466	466	466	466
Equivalent CO <sub>2</sub> charge	t	21,0	21,0	28,0	28,0	33,6	33,6	33,6	33,6	42,0	47,0
Water tank volume	l	500	500	500	500	500	500	500	500	500	500

Performances are referred to the following conditions:

- (1) Heating: Ambient temperature 7°C DB, 6°C WB, water temperature 30/35°C.
- (2) Average conditions, low temperature, variable - Reg EU 811/2013
- (3) Cooling: ambient air temperature 35°C, evaporator water temperature in/out 12/7 °C.

(4) TER: Total Energy Ratio - cold circuit 12/7°C, hot circuit 30/35°C.

(5) Sound power level in accordance with ISO 3744.

(6) Sound pressure level at 10 mt from the unit in free field conditions in accordance with ISO 3744.

## Reversible heating/cooling version (RV)

HA/XL/RV P4U		452	512	682	752	912	1102	1152	1352	1502	1612
Heating capacity (EN14511) <sup>(1)</sup>	kW	45,2	51,3	68,3	74,4	90,8	103,0	113,0	134,0	150,0	161,0
Total input power (EN14511) <sup>(1)</sup>	kW	11,1	12,4	15,5	17,4	21,2	24,0	26,5	31,3	35,8	38,0
COP (EN14511) <sup>(1)</sup>	W/W	4,07	4,14	4,41	4,28	4,28	4,29	4,26	4,28	4,19	4,24
Energy Class <sup>(2)</sup>		A++	A++	A++	A++	A++	A++	A++	A++	A++	A++
SCOP <sup>(2)</sup>	kWh/kWh	4,00	4,10	4,20	4,20	3,90	4,30	4,30	4,10	4,10	4,10
$\eta_{s,h}$ <sup>(2)</sup>	%	157	161	165	165	153	169	169	161	161	161
Cooling capacity (EN14511) <sup>(3)</sup>	kW	37,0	42,5	56,1	59,0	75,3	84,5	93,3	111,0	122,0	132,0
Total input power (EN14511) <sup>(3)</sup>	kW	14,3	16,7	21,7	25,6	26,7	31,0	35,8	38,3	45,4	49,6
EER (EN14511) <sup>(3)</sup>	W/W	2,59	2,54	2,59	2,30	2,82	2,73	2,61	2,90	2,69	2,66
TER (EN14511) <sup>(4)</sup>	W/W	9,61	9,84	10,2	9,82	10,1	9,91	10,1	9,86	9,57	9,80
Sound power <sup>(5)</sup>	dB (A)	72	72	72	73	75	76	78	80	81	81
Sound pressure <sup>(6)</sup>	dB (A)	40	40	40	41	43	44	46	48	49	49
HE/XL/RV P4U		452	512	682	752	912	1102	1152	1352	1502	1612
Heating capacity (EN14511) <sup>(1)</sup>	kW	44,8	51,4	68,6	74,5	90,1	102,0	112,0	133,0	149,0	159,0
Total input power (EN14511) <sup>(1)</sup>	kW	10,6	12,2	15,3	17,3	19,7	22,6	24,9	29,0	33,5	35,7
COP (EN14511) <sup>(1)</sup>	W/W	4,23	4,21	4,48	4,31	4,57	4,51	4,50	4,59	4,45	4,45
Energy Class <sup>(2)</sup>		A++	A++	A++	A++	A++	A++	A+++	A++	A++	A++
SCOP <sup>(2)</sup>	kWh/kWh	4,20	4,20	4,31	4,24	4,33	4,40	4,49	4,34	4,34	4,35
$\eta_{s,h}$ <sup>(2)</sup>	%	165	165	169	167	170	173	177	171	171	171
Cooling capacity (EN14511) <sup>(3)</sup>	kW	36,3	42,6	56,3	59,8	73,8	82,7	91,2	108,0	120,0	130,0
Total input power (EN14511) <sup>(3)</sup>	kW	14,2	16,5	21,5	25,1	26,1	30,7	35,5	37,5	44,5	48,7
EER (EN14511) <sup>(3)</sup>	W/W	2,56	2,58	2,62	2,38	2,83	2,69	2,57	2,88	2,70	2,67
TER (EN14511) <sup>(4)</sup>	W/W	9,61	9,84	10,2	9,82	10,1	9,91	10,1	9,86	9,57	9,80
Sound power <sup>(5)</sup>	dB (A)	78	76	76	77	81	83	84	85	84	86
Sound pressure <sup>(6)</sup>	dB (A)	46	44	44	45	49	51	52	53	52	54
Power supply	V/Ph/Hz	400/3/50	400/3/50	400/3/50	400/3/50	400/3/50	400/3/50	400/3/50	400/3/50	400/3/50	400/3/50
Compressors / Circuits	n° / n°	2 / 1	2 / 1	2 / 1	2 / 1	2 / 1	2 / 1	2 / 1	2 / 1	2 / 1	2 / 1
Fans	n°	2	2	2	2	2	2	2	3	3	3
Refrigerant		R454B	R454B	R454B	R454B	R454B	R454B	R454B	R454B	R454B	R454B
Refrigerant charge	kg	10,0	14,5	19,0	19,0	27,0	27,0	36,0	36,0	36,0	36,0
Global warming potential (GWP)		466	466	466	466	466	466	466	466	466	466
Equivalent CO <sub>2</sub> charge	t	4,7	6,8	8,8	8,8	12,6	12,6	12,6	16,8	16,8	16,8
Water tank volume	l	140	140	300	300	300	300	300	500	500	500
HA/XL/RV P4U		1792	2012	2304	2312	2654	2954	3214	3514	3954	4454
Heating capacity (EN14511) <sup>(1)</sup>	kW	182,0	201,0	230,0	228,0	269,0	301,0	322,0	367,0	408,0	459,0
Total input power (EN14511) <sup>(1)</sup>	kW	42,8	47,2	53,6	52,7	64,2	73,3	78,2	89,1	98,9	110,0
COP (EN14511) <sup>(1)</sup>	W/W	4,25	4,26	4,29	4,33	4,19	4,11	4,12	4,12	4,13	4,17
Energy Class <sup>(2)</sup>		A++	A++	A++	A++	A++	A++	A++	A++	A++	A++
SCOP <sup>(2)</sup>	kWh/kWh	4,20	4,20	4,00	4,20	3,90	3,90	4,00	4,00	4,00	3,90
$\eta_{s,h}$ <sup>(2)</sup>	%	165	165	157	165	153	153	157	157	157	153
Cooling capacity (EN14511) <sup>(3)</sup>	kW	154,0	171,0	191	188,0	222,0	247,0	263,0	294,0	342,0	374,0
Total input power (EN14511) <sup>(3)</sup>	kW	58,9	63,9	72,0	72,2	80,1	94,0	103,0	121,0	128,0	145,0
EER (EN14511) <sup>(3)</sup>	W/W	2,61	2,68	2,65	2,60	2,77	2,63	2,55	2,43	2,67	2,58
TER (EN14511) <sup>(4)</sup>	W/W	10,3	10,1	10,1	10,0	9,81	9,52	9,58	9,48	9,82	9,78
Sound power <sup>(5)</sup>	dB (A)	81	83	81	84	83	84	84	84	86	87
Sound pressure <sup>(6)</sup>	dB (A)	49	51	48	51	51	52	52	51	53	54
HE/XL/RV P4U		1792	2012	2304	2312	2654	2954	3214	3514	3954	4454
Heating capacity (EN14511) <sup>(1)</sup>	kW	180,0	200,0	233,0	226,0	263,0	293,0	313,0	354,0	397,0	436,0
Total input power (EN14511) <sup>(1)</sup>	kW	40,5	44,9	50,5	50,3	59,2	68,4	73,2	84,1	92,3	103,0
COP (EN14511) <sup>(1)</sup>	W/W	4,44	4,45	4,42	4,49	4,44	4,28	4,28	4,21	4,30	4,23
Energy Class <sup>(2)</sup>		A+++	A++	A++	A+++	A++	A++	A++	A++	A++	A++
SCOP <sup>(2)</sup>	kWh/kWh	4,48	4,40	4,43	4,46	4,32	4,33	4,35	4,31	4,33	4,30
$\eta_{s,h}$ <sup>(2)</sup>	%	176	173	174	175	170	170	171	169	169	169
Cooling capacity (EN14511) <sup>(3)</sup>	kW	151,0	166,0	187,0	181,0	219,0	244,0	259,0	286,0	337,0	367,0
Total input power (EN14511) <sup>(3)</sup>	kW	58,8	64,7	71,2	73,6	77,2	91,4	101,0	120,0	125,0	143,0
EER (EN14511) <sup>(3)</sup>	W/W	2,57	2,57	2,63	2,46	2,84	2,67	2,56	2,38	2,70	2,57
TER (EN14511) <sup>(4)</sup>	W/W	10,3	10,1	10,1	10,0	9,81	9,52	9,58	9,48	9,82	9,78
Sound power <sup>(5)</sup>	dB (A)	87	90	87	89	87	87	89	89	92	89
Sound pressure <sup>(6)</sup>	dB (A)	55	57	55	56	55	54	56	57	59	56
Power supply	V/Ph/Hz	400/3/50	400/3/50	400/3/50	400/3/50	400/3/50	400/3/50	400/3/50	400/3/50	400/3/50	400/3/50
Compressors / Circuits	n° / n°	2 / 1	2 / 1	4 / 2	2 / 1	4 / 2	4 / 2	4 / 2	4 / 2	4 / 2	4 / 2
Fans	n°	3	3	4	3	6	6	6	6	8	8
Refrigerant		R454B	R454B	R454B	R454B	R454B	R454B	R454B	R454B	R454B	R454B
Refrigerant charge	kg	45,0	45,0	60,0	60,0	72,0	72,0	72,0	72,0	90,0	100,0
Global warming potential (GWP)		466	466	466	466	466	466	466	466	466	466
Equivalent CO <sub>2</sub> charge	t	20,9	20,9	27,9	27,9	33,6	33,6	33,6	33,6	41,9	46,6
Water tank volume	l	500	500	500	500	500	500	500	500	500	500

Performances are referred to the following conditions:

- (1) Heating: Ambient temperature 7°C DB, 6°C WB, water temperature 30/35°C.  
 (2) Average conditions, low temperature, variable - Reg EU 811/2013  
 (3) Cooling: ambient air temperature 35°C, evaporator water temperature in/out 12/7 °C.

(4) TER: Total Energy Ratio - cold circuit 12/7°C, hot circuit 30/35°C.

(5) Sound power level in accordance with ISO 3744.

(6) Sound pressure level at 10 mt from the unit in free field conditions in accordance with ISO 3744.



Reversible heating/cooling version (RV)



HA/LS/RV P4S		452	512	682	752	912	1102	1152	1352	1502	1612
Heating capacity (EN14511) <sup>(1)</sup>	kW	45,4	51,4	68,7	74,6	87,9	101,0	112,0	129,0	150,0	161,0
Total input power (EN14511) <sup>(1)</sup>	kW	11,7	13,0	16,3	18,4	22,7	25,3	28,4	33,5	38,4	40,6
COP (EN14511) <sup>(1)</sup>	W/W	3,88	3,95	4,21	4,05	3,87	3,99	3,94	3,85	3,91	3,97
Energy Class <sup>(2)</sup>		A+	A+	A++	A++	A+	A++	A++	A+	A+	A+
SCOP <sup>(2)</sup>	kWh/kWh	3,68	3,74	4,08	4,00	3,52	3,85	3,86	3,69	3,69	3,75
η <sub>s,h</sub> <sup>(2)</sup>	%	144	147	160	157	138	151	151	145	145	147
Cooling capacity (EN14511) <sup>(3)</sup>	kW	37,7	43,2	57,1	61,0	76,7	86,9	96,0	112,0	125,0	136,0
Total input power (EN14511) <sup>(3)</sup>	kW	14,0	16,4	21,3	24,6	26,5	30,3	35,0	38,3	44,3	48,5
EER (EN14511) <sup>(3)</sup>	W/W	2,69	2,63	2,68	2,48	2,89	2,87	2,74	2,92	2,82	2,80
TER (EN14511) <sup>(4)</sup>	W/W	5,58	5,78	6,04	5,82	5,98	5,94	6,04	5,91	5,80	5,92
Sound power <sup>(5)</sup>	dB (A)	77	76	77	78	82	83	85	86	87	87
Sound pressure <sup>(6)</sup>	dB (A)	46	44	45	46	50	51	53	54	55	55
HE/LS/RV P4S		452	512	682	752	912	1102	1152	1352	1502	1612
Heating capacity (EN14511) <sup>(1)</sup>	kW	45,0	51,5	68,7	75,0	91,0	102,0	114,0	134,0	150,0	161,0
Total input power (EN14511) <sup>(1)</sup>	kW	11,2	13,0	16,3	18,4	21,4	24,5	27,0	31,6	36,6	38,9
COP (EN14511) <sup>(1)</sup>	W/W	4,02	3,96	4,21	4,08	4,25	4,16	4,22	4,24	4,10	4,14
Energy Class <sup>(2)</sup>		A++	A++	A++	A++	A++	A++	A++	A++	A++	A++
SCOP <sup>(2)</sup>	kWh/kWh	3,98	3,90	4,19	4,13	3,92	4,10	4,14	4,02	4,08	4,03
η <sub>s,h</sub> <sup>(2)</sup>	%	156	153	165	162	154	161	163	158	160	158
Cooling capacity (EN14511) <sup>(3)</sup>	kW	36,9	43,2	57,6	61,5	76,5	85,5	95,0	112,0	124,0	134,0
Total input power (EN14511) <sup>(3)</sup>	kW	14,1	16,5	21,2	24,5	25,8	30,3	34,6	37,3	43,6	48,1
EER (EN14511) <sup>(3)</sup>	W/W	2,62	2,62	2,72	2,51	2,97	2,82	2,75	3,00	2,84	2,79
TER (EN14511) <sup>(4)</sup>	W/W	6,19	5,78	6,04	5,82	5,98	5,94	6,04	5,91	5,80	5,92
Sound power <sup>(5)</sup>	dB (A)	78	79	81	82	86	87	88	89	89	90
Sound pressure <sup>(6)</sup>	dB (A)	46	47	49	50	54	55	56	57	56	57
Power supply	V/Ph/Hz	400/3/50	400/3/50	400/3/50	400/3/50	400/3/50	400/3/50	400/3/50	400/3/50	400/3/50	400/3/50
Compressors / Circuits	n° / n°	2 / 1	2 / 1	2 / 1	2 / 1	2 / 1	2 / 1	2 / 1	2 / 1	2 / 1	2 / 1
Fans	n°	2	2	2	2	2	2	2	3	3	3
Refrigerant		R454B	R454B	R454B	R454B	R454B	R454B	R454B	R454B	R454B	R454B
Refrigerant charge	kg	10,0	14,5	19,0	19,0	27,0	27,0	27,0	36,0	36,0	36,0
Global warming potential (GWP)		466	466	466	466	466	466	466	466	466	466
Equivalent CO <sub>2</sub> charge	t	4,7	6,8	8,9	8,9	12,6	12,6	12,6	16,8	16,8	16,8
Water tank volume	l	140	140	300	300	300	300	300	500	500	500

HA/LS/RV P4S		1792	2012	2304	2312	2654	2954	3214	3514	3954	4454
Heating capacity (EN14511) <sup>(1)</sup>	kW	181,0	200,0	226,0	226,0	261,0	297,0	319,0	365,0	404,0	454,0
Total input power (EN14511) <sup>(1)</sup>	kW	45,7	50,0	56,7	56,0	68,5	78,0	82,8	94,1	105,0	116,0
COP (EN14511) <sup>(1)</sup>	W/W	3,96	4,00	3,99	4,04	3,81	3,81	3,85	3,88	3,85	3,91
Energy Class <sup>(2)</sup>		A++	A++	A+	A++	A+	A+	A+	A+	A+	A+
SCOP <sup>(2)</sup>	kWh/kWh	3,99	3,98	3,68	4,04	3,51	3,55	3,69	3,69	3,60	3,63
η <sub>s,h</sub> <sup>(2)</sup>	%	157	156	144	159	137	139	145	145	141	142
Cooling capacity (EN14511) <sup>(3)</sup>	kW	160,0	175,0	197,0	195,0	229,0	254,0	271,0	306,0	352,0	387,0
Total input power (EN14511) <sup>(3)</sup>	kW	57,0	62,8	70,3	69,4	78,3	91,9	100,0	116,0	125,0	141,0
EER (EN14511) <sup>(3)</sup>	W/W	2,81	2,79	2,80	2,81	2,92	2,76	2,71	2,64	2,82	2,74
TER (EN14511) <sup>(4)</sup>	W/W	6,20	6,11	6,01	6,11	5,89	5,77	5,83	5,81	6,76	6,89
Sound power <sup>(5)</sup>	dB (A)	89	89	88	91	89	90	90	92	92	94
Sound pressure <sup>(6)</sup>	dB (A)	57	57	56	58	56	58	58	60	59	62
HE/LS/RV P4S		1792	2012	2304	2312	2654	2954	3214	3514	3954	4454
Heating capacity (EN14511) <sup>(1)</sup>	kW	182,0	202,0	227,0	230,0	261,0	298,0	320,0	366,0	405,0	455,0
Total input power (EN14511) <sup>(1)</sup>	kW	44,1	48,5	54,6	54,3	64,6	74,2	79,0	90,6	100,0	112,0
COP (EN14511) <sup>(1)</sup>	W/W	4,13	4,16	4,16	4,24	4,04	4,02	4,05	4,04	4,05	4,06
Energy Class <sup>(2)</sup>		A++	A++	A++	A++	A++	A++	A++	A++	A++	A++
SCOP <sup>(2)</sup>	kWh/kWh	4,25	4,20	4,12	4,20	3,92	4,01	4,05	4,06	4,04	4,01
η <sub>s,h</sub> <sup>(2)</sup>	%	167	165	162	165	154	157	159	159	159	157
Cooling capacity (EN14511) <sup>(3)</sup>	kW	158,0	173,0	194	192,0	227,0	252,0	269,0	304,0	349,0	384,0
Total input power (EN14511) <sup>(3)</sup>	kW	56,9	62,7	69,8	69,7	76,8	90,4	99,0	115,0	124,0	140,0
EER (EN14511) <sup>(3)</sup>	W/W	2,78	2,76	2,78	2,75	2,96	2,79	2,72	2,64	2,81	2,74
TER (EN14511) <sup>(4)</sup>	W/W	6,20	6,11	6,01	6,11	5,89	5,77	5,83	5,81	6,76	6,89
Sound power <sup>(5)</sup>	dB (A)	90	92	91	92	91	92	92	93	91	89
Sound pressure <sup>(6)</sup>	dB (A)	58	59	58	60	58	59	59	60	59	56
Power supply	V/Ph/Hz	400/3/50	400/3/50	400/3/50	400/3/50	400/3/50	400/3/50	400/3/50	400/3/50	400/3/50	400/3/50
Compressors / Circuits	n° / n°	2 / 1	2 / 1	4 / 2	2 / 1	4 / 2	4 / 2	4 / 2	4 / 2	4 / 2	4 / 2
Fans	n°	3	3	4	3	6	6	6	6	8	8
Refrigerant		R454B	R454B	R454B	R454B	R454B	R454B	R454B	R454B	R454B	R454B
Refrigerant charge	kg	45,0	45,0	60,0	60,0	72,0	72,0	72,0	72,0	90,0	100,0
Global warming potential (GWP)		466	466	466	466	466	466	466	466	466	466
Equivalent CO <sub>2</sub> charge	t	20,9	20,9	27,9	27,9	33,6	33,6	33,6	33,6	41,9	46,6
Water tank volume	l	500	500	500	500	500	500	500	500	500	500

Performances are referred to the following conditions:  
 (1) Heating: Ambient temperature 7°C DB, 6°C WB, water temperature 30/35°C.  
 (2) Average conditions, low temperature, variable - Reg EU 811/2013  
 (3) Cooling: ambient air temperature 35°C, evaporator water temperature in/out 12/7 °C.

(4) TER: Total Energy Ratio - cold circuit 12/7°C, hot circuit 30/35°C.  
 (5) Sound power level in accordance with ISO 3744.  
 (6) Sound pressure level at 10 mt from the unit in free field conditions in accordance with ISO 3744.

## Reversible heating/cooling version (RV)

<b>HA/XL/RV P4S</b>		<b>452</b>	<b>512</b>	<b>682</b>	<b>752</b>	<b>912</b>	<b>1102</b>	<b>1152</b>	<b>1352</b>	<b>1502</b>	<b>1612</b>
Heating capacity (EN14511) <sup>(1)</sup>	kW	45,2	51,0	67,6	73,6	89,9	102,0	112,0	133,0	148,0	160,0
Total input power (EN14511) <sup>(1)</sup>	kW	11,5	13,0	16,2	18,2	22,2	25,0	27,6	32,8	37,9	39,9
COP (EN14511) <sup>(1)</sup>	W/W	3,93	3,92	4,17	4,04	4,05	4,08	4,06	4,05	3,91	4,01
Energy Class <sup>(2)</sup>		A++	A++	A++	A++	A+	A++	A++	A++	A++	A++
SCOP <sup>(2)</sup>	kWh/kWh	3,88	3,97	4,07	4,02	3,79	4,12	4,14	3,98	3,95	4,02
η <sub>s,h</sub> <sup>(2)</sup>	%	152	156	160	158	149	162	163	156	155	158
Cooling capacity (EN14511) <sup>(3)</sup>	kW	37,0	42,5	56,1	59,0	75,3	84,5	93,3	111,0	122,0	132,0
Total input power (EN14511) <sup>(3)</sup>	kW	14,3	16,7	21,7	25,6	26,7	31,0	35,8	38,3	45,4	49,6
EER (EN14511) <sup>(3)</sup>	W/W	2,59	2,54	2,59	2,30	2,82	2,73	2,61	2,90	2,69	2,66
TER (EN14511) <sup>(4)</sup>	W/W	5,58	5,78	6,04	5,82	5,98	5,94	6,04	5,91	5,80	5,92
Sound power <sup>(5)</sup>	dB (A)	72	72	72	73	75	76	78	80	81	81
Sound pressure <sup>(6)</sup>	dB (A)	40	40	40	41	43	44	46	48	49	49
<b>HE/XL/RV P4S</b>		<b>452</b>	<b>512</b>	<b>682</b>	<b>752</b>	<b>912</b>	<b>1102</b>	<b>1152</b>	<b>1352</b>	<b>1502</b>	<b>1612</b>
Heating capacity (EN14511) <sup>(1)</sup>	kW	44,6	51,2	68,2	74,1	89,5	101,0	111,0	132,0	148,0	158,0
Total input power (EN14511) <sup>(1)</sup>	kW	11,0	12,7	16,0	18,0	20,6	23,6	26,0	30,5	35,3	37,4
COP (EN14511) <sup>(1)</sup>	W/W	4,05	4,03	4,26	4,12	4,34	4,28	4,27	4,33	4,19	4,22
Energy Class <sup>(2)</sup>		A++	A++	A++	A++	A++	A++	A++	A++	A++	A++
SCOP <sup>(2)</sup>	kWh/kWh	4,00	4,02	4,19	4,13	4,24	4,35	4,39	4,29	4,27	4,24
η <sub>s,h</sub> <sup>(2)</sup>	%	157	158	165	162	167	171	173	169	168	167
Cooling capacity (EN14511) <sup>(3)</sup>	kW	36,3	42,6	56,3	59,8	73,8	82,7	91,2	108,0	120,0	130,0
Total input power (EN14511) <sup>(3)</sup>	kW	14,2	16,5	21,5	25,1	26,1	30,7	35,5	37,5	44,5	48,7
EER (EN14511) <sup>(3)</sup>	W/W	2,56	2,58	2,62	2,38	2,83	2,69	2,57	2,88	2,70	2,67
TER (EN14511) <sup>(4)</sup>	W/W	6,19	5,78	6,04	5,82	5,98	5,94	6,04	5,91	5,80	5,92
Sound power <sup>(5)</sup>	dB (A)	78	76	76	77	81	83	84	85	84	86
Sound pressure <sup>(6)</sup>	dB (A)	46	44	44	45	49	51	52	53	52	54
Power supply	V/Ph/Hz	400/3/50	400/3/50	400/3/50	400/3/50	400/3/50	400/3/50	400/3/50	400/3/50	400/3/50	400/3/50
Compressors / Circuits	n° / n°	2 / 1	2 / 1	2 / 1	2 / 1	2 / 1	2 / 1	2 / 1	2 / 1	2 / 1	2 / 1
Fans	n°	2	2	2	2	2	2	2	3	3	3
Refrigerant		R454B	R454B	R454B	R454B	R454B	R454B	R454B	R454B	R454B	R454B
Refrigerant charge	kg	10,0	14,5	19,0	19,0	27,0	27,0	27,0	36,0	36,0	36,0
Global warming potential (GWP)		466	466	466	466	466	466	466	466	466	466
Equivalent CO <sub>2</sub> charge	t	4,7	6,8	8,9	8,9	12,6	12,6	12,6	16,8	16,8	16,8
Water tank volume	l	140	140	300	300	300	300	300	500	500	500
<b>HA/XL/RV P4S</b>		<b>1792</b>	<b>2012</b>	<b>2304</b>	<b>2312</b>	<b>2654</b>	<b>2954</b>	<b>3214</b>	<b>3514</b>	<b>3954</b>	<b>4454</b>
Heating capacity (EN14511) <sup>(1)</sup>	kW	181,0	200,0	229,0	227,0	267,0	300,0	320,0	365,0	407,0	456,0
Total input power (EN14511) <sup>(1)</sup>	kW	44,2	49,3	55,9	55,0	66,8	76,6	80,9	92,0	101,0	113,0
COP (EN14511) <sup>(1)</sup>	W/W	4,10	4,06	4,10	4,13	4,00	3,92	3,96	3,97	4,03	4,04
Energy Class <sup>(2)</sup>		A++	A++	A++	A++	A+	A+	A++	A++	A++	A++
SCOP <sup>(2)</sup>	kWh/kWh	4,09	4,09	3,86	4,09	3,82	3,79	3,89	3,88	3,85	3,84
η <sub>s,h</sub> <sup>(2)</sup>	%	161	161	151	161	150	149	153	152	151	151
Cooling capacity (EN14511) <sup>(3)</sup>	kW	154,0	171,0	191	188,0	222,0	247,0	263,0	294,0	342,0	374,0
Total input power (EN14511) <sup>(3)</sup>	kW	58,9	63,9	72,0	72,2	80,1	94,0	103,0	121,0	128,0	145,0
EER (EN14511) <sup>(3)</sup>	W/W	2,61	2,68	2,65	2,60	2,77	2,63	2,55	2,43	2,67	2,58
TER (EN14511) <sup>(4)</sup>	W/W	6,20	6,11	6,01	6,11	5,89	5,77	5,83	5,81	6,76	6,76
Sound power <sup>(5)</sup>	dB (A)	81	83	81	84	83	84	84	84	86	87
Sound pressure <sup>(6)</sup>	dB (A)	49	51	48	51	51	52	52	51	53	54
<b>HE/XL/RV P4S</b>		<b>1792</b>	<b>2012</b>	<b>2304</b>	<b>2312</b>	<b>2654</b>	<b>2954</b>	<b>3214</b>	<b>3514</b>	<b>3954</b>	<b>4454</b>
Heating capacity (EN14511) <sup>(1)</sup>	kW	179,0	199,0	222,0	225,0	260,0	291,0	312,0	351,0	396,0	434,0
Total input power (EN14511) <sup>(1)</sup>	kW	42,1	47,0	52,7	52,7	61,6	71,7	75,9	87,0	95,3	107,0
COP (EN14511) <sup>(1)</sup>	W/W	4,25	4,23	4,21	4,27	4,22	4,06	4,11	4,03	4,16	4,06
Energy Class <sup>(2)</sup>		A++	A++	A++	A++	A++	A++	A++	A++	A++	A++
SCOP <sup>(2)</sup>	kWh/kWh	4,33	4,33	4,37	4,31	4,14	4,18	4,18	4,19	4,20	4,07
η <sub>s,h</sub> <sup>(2)</sup>	%	170	170	172	169	163	164	164	165	165	160
Cooling capacity (EN14511) <sup>(3)</sup>	kW	151,0	166,0	187,0	181,0	219,0	244,0	259,0	286,0	337,0	367,0
Total input power (EN14511) <sup>(3)</sup>	kW	58,8	64,7	71,2	73,6	77,2	91,4	101,0	120,0	125,0	143,0
EER (EN14511) <sup>(3)</sup>	W/W	2,57	2,57	2,63	2,46	2,84	2,67	2,56	2,38	2,70	2,57
TER (EN14511) <sup>(4)</sup>	W/W	6,20	6,11	6,01	6,11	5,89	5,77	5,83	5,81	6,76	6,89
Sound power <sup>(5)</sup>	dB (A)	87	90	87	89	87	87	89	89	92	89
Sound pressure <sup>(6)</sup>	dB (A)	55	57	55	56	55	54	56	57	59	56
Power supply	V/Ph/Hz	400/3/50	400/3/50	400/3/50	400/3/50	400/3/50	400/3/50	400/3/50	400/3/50	400/3/50	400/3/50
Compressors / Circuits	n° / n°	2 / 1	2 / 1	4 / 2	2 / 1	4 / 2	4 / 2	4 / 2	4 / 2	4 / 2	4 / 2
Fans	n°	3	3	4	3	6	6	6	6	8	8
Refrigerant		R454B	R454B	R454B	R454B	R454B	R454B	R454B	R454B	R454B	R454B
Refrigerant charge	kg	45,0	45,0	60,0	60,0	72,0	72,0	72,0	72,0	90,0	100,0
Global warming potential (GWP)		466	466	466	466	466	466	466	466	466	466
Equivalent CO <sub>2</sub> charge	t	20,9	20,9	27,9	27,9	33,6	33,6	33,6	33,6	41,9	46,6
Water tank volume	l	500	500	500	500	500	500	500	500	500	500

Performances are referred to the following conditions:

- (1) Heating: Ambient temperature 7°C DB, 6°C WB, water temperature 30/35°C.
- (2) Average conditions, low temperature, variable - Reg EU 811/2013
- (3) Cooling: ambient air temperature 35°C, evaporator water temperature in/out 12/7°C.

(4) TER: Total Energy Ratio - cold circuit 12/7°C, hot circuit 30/35°C.

(5) Sound power level in accordance with ISO 3744.

(6) Sound pressure level at 10 mt from the unit in free field conditions in accordance with ISO 3744.

## COMPONENTS

### FRAME

All units are made from hot-galvanised sheet steel, painted with polyurethane powder enamel and stoved at 180°C to provide maximum protection against corrosion. The frame is self-supporting with removable panels. All screws and rivets used are made from stainless steel. The standard colour of the units is RAL9018.

### REFRIGERANT CIRCUIT

The refrigerant circuit is assembled using internationally recognised brand name components with all brazing and welding being performed in accordance with ISO 97/23. The refrigerant utilised is R454B. The refrigerant circuit includes: sight glass, filter drier, electronic expansion valves, 4 way reversing valve, check valves, liquid receiver, liquid separator, schrader valves for maintenance and control, pressure safety device (for compliance with PED regulations).

### COMPRESSORS

The compressors are scroll type, with crankcase resistance and thermal protection, installed in a separate compartment from the airflow in order to reduce noise. When the unit is on stand-by mode, the crankcase heater is always powered. Through the unit's front panel, it is possible to inspect and repair the compressors even when the unit is running.

The compressors used are tandem type. This solution allows a significantly higher efficiency with partial loads compared to the option with independent refrigerant circuits. The control system constantly monitors the discharge temperature of the single compressors.

### SOURCE HEAT EXCHANGER

The source heat exchanger is made from 3/8" copper pipes and 0,1mm at least thick aluminium fins with the tubes being mechanically expanded into the aluminium fins in order to maximise heat transfer. Furthermore, the design guarantees a low air side pressure drop thus enabling the use of low rotation speed (and hence low noise) fans. All heat exchangers are supplied standard with fins hydrophilic coating "Blue Fins".

### USER CIRCUIT HEAT EXCHANGERS

The user heat exchanger is a braze welded, plate type heat exchanger, manufactured from AISI 316 stainless steel. The use of this type of exchanger results in a massive reduction of the refrigerant charge of the unit compared to a traditional shell-in-tube type. A further advantage is a reduction in the overall dimensions of the unit. The exchangers are factory insulated with flexible close cell material and can be fitted with an antifreeze heater (accessory). Each exchanger is fitted with a temperature sensor on the discharge water side for antifreeze protection.

### FANS

The fans are direct drive axial type with aerofoil blades, are statically and dynamically balanced and are supplied complete with a safety fan guard complying with the requirements of EN 60335. They are fixed to the unit frame via rubber anti-vibration mountings. The electric motors, in HA versions are 6 poles type and a phase-cut regulator controls their speed of rotation to increase energy efficiency and allow them to be used over a wider operating range. In the HE versions, the fans are electronic type, with permanent magnet motors with an integrated driver that modulates the speed of rotation. The motors are fitted with integrated thermal overload protection and have a moisture protection rating of IP 54.

### MICROPROCESSORS

All units are supplied as standard with microprocessor controls. The microprocessor controls the following functions: control of the water temperature, antifreeze protection, compressor timing, compressor automatic starting sequence (For multiple

compressors), alarm reset.

The control panel is supplied with display showing all operational icons. The microprocessor is set for automatic defrost (when operating in severe ambient conditions) and for summer/ winter change over. The control also manages the integration with other heating sources (electric heaters, boilers, solar panels etc) and both the heating circuit pump and the domestic hot water circuit pump. If required (available as an option), the microprocessor can be configured in order for it to connect to a site BMS system thus enabling remote control and management.

### ELECTRIC ENCLOSURE

The enclosure is manufactured in order to comply with the requirements of the electromagnetic compatibility standards 2014/35/UE and 2014/30/UE. Access to the enclosure is achieved by removing the front panel of the unit. The following components are supplied as standard on all units: main switch, a sequence relay that disables the power supply in the event that the phase sequence is incorrect (scroll compressors can be damaged if they rotate in the wrong direction), thermal overloads (protection of pumps and fans), compressor fuses, control circuit automatic breakers, compressor contactors, fan contactors and pump contactors. The terminal board has volt free contacts for remote ON-OFF, Summer/ winter change over (heat pumps only) and general alarm.

### CONTROL AND PROTECTION DEVICES

All units are standardly equipped with several control and safety devices: water return temperature sensor, installed on the water return pipe of the system, and anti-freeze probe, installed on the water supply pipe to the system high-pressure switch with automatic reset. There are also included a low-pressure automatic reset, pressure transducer (used to optimize the defrosting cycle and modulate the rotation speed of the fans according to external conditions), Freon side safety device, compressor thermal protection, fan thermal protection, flow switch, and external air compensation probe.

### LEAK DETECTOR

When the unit is powered ON, the sensor is warmed up/initialised (duration approx. 1min.).

During this period, the LEDs inside the sensor blink, the refrigerant leakage alarm is notified and the 24Vac auxiliary circuit is switched off. After this period, if in the absence of any further feedback from the sensor, the PLC control is powered up and the unit is ready to operate. If refrigerant leaks occur, the sensor is activated and the power supply to the control PLC is immediately switched off until the sensor indicates the refrigerant is still present.

## VERSIONI

### Versione supersilenziata HA/XL HE/XL

All XL super silenced units are supplied equipped with a special vibration-damping system consisting of a floating basement placed upon the unit's frame, through the interposition of high-damping steel springs.

The compressors are housed on this floating base and are in turn fixed by means of rubber anti-vibration supports.

The enclosure is manufactured from galvanized steel sandwich panels that have a micro-perforated inner skin and a core of 30 mm thick, high density (25 kg/m<sup>3</sup>) soundproofing mat. The entire arrangement provides a double damping system and acoustic attenuation. The compressor refrigerant pipes are connected to the refrigerant circuit through "anaconda" flexible connections. Flexible connections are also used on the water pipework within the unit. The combination of these systems results in an overall noise reduction in the region of 6-8 dB(A) compared to units in standard configuration.

### RV Version

Reversible heating/cooling unit, with cycle reversal on the cooling circuit.

### HA Version

High efficiency version, according to current standard. Unit equipped with AC fans.

### HE Version

High efficiency version, according to current standard. Unit equipped with EC fans.

### LS Version

This version includes the complete acoustic insulation of the unit with compressor jackets and insulating material made with high density media and the interposition of heavy bitumen layer.

### P4U Version

The P4U units use 4 hydraulic connections and are used in modern 4-pipe systems. In these systems, cold and hot water is always available (in every period of the year) and present in the specific hydraulic circuit. These systems allow the simultaneous production of cold water and hot water using 4 hydraulic connections, 2 connections are related to the hot water circuit, 2 connections are related to the cold water circuit. The plant thus conceived is able to heat and, at the same time, if required, to cool with very high energy efficiencies. In this configuration, however, the units are also able to produce hot or cold water separately at any time of the year.

The units are supplied with 2 heat exchangers, one dedicated to the production of cold water and one dedicated to the production of hot water. The operating modes are:

**1. User water heating:** The unit behaves like a normal air/water heat pump in heating mode, using the finned heat exchanger as the source and the A plate heat exchanger as user.

**2. User water cooling:** The unit behaves like a normal air / water chiller in cooling mode, using the finned exchanger as the source and the B plate heat exchanger as user.

**3. Simultaneous user Cooling + heating:** The unit behaves like a water / water heat pump, using the plate heat exchanger B as the cold user and the plate heat exchanger A as hot user. This version is not able to produce domestic hot water.

## P4U VERSION

User water heating

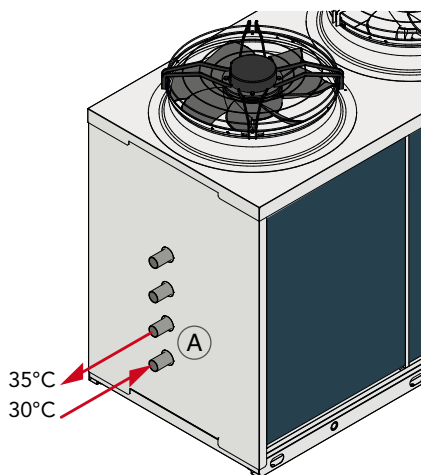

User water cooling

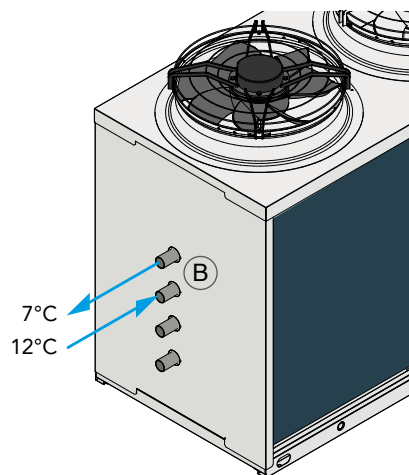

Simultaneous user  
Cooling + heating

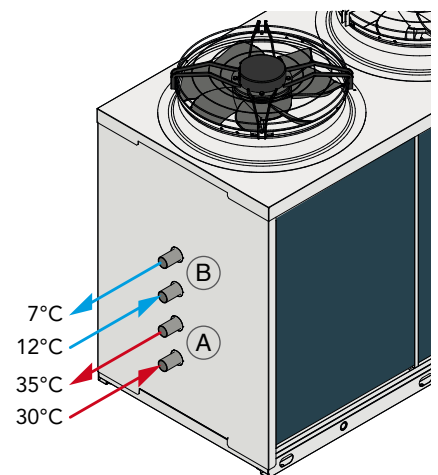

The above scheme is for illustrative purposes only. For the correct pipes placement, please refer to the units technical manual.

## OPERATION LIMITS

(HA/HE versions)

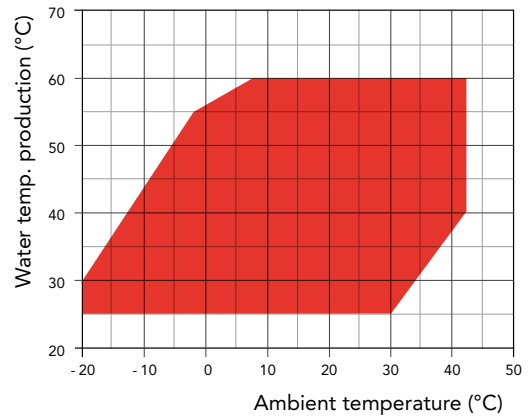

■ Heating mode

(RV versions Only)

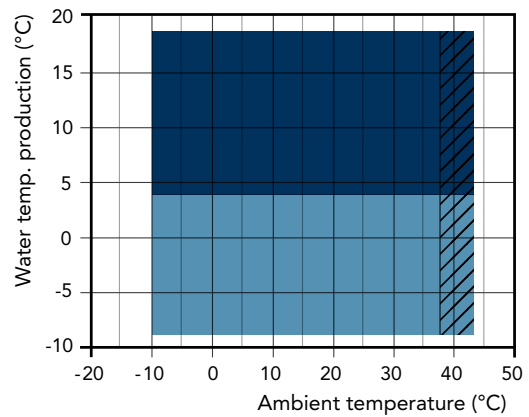

■ Cooling mode

■ Glycol set-up

▨ Possible noise increase for XL versions

### P4S Version

The P4S units have been designed to meet the needs of 2 + 2 pipe systems (2 user side pipes, 2 domestic hot water pipes) throughout the year. The units are supplied with 2 exchangers, one dedicated to the production of the user cold and hot water and one dedicated to the production of domestic hot water only (D.H.W.). The production of domestic hot water always has priority. In winter mode the activation of D.H.W. production temporarily stops the production of the user hot water, which is restored when the D.H.W. accumulation reaches the temperature set. In summer mode the unit will switch to cooling (by activating the reverse cycle valve installed in the refrigerant circuit) and any request for domestic hot water will allow, at the same time, the production of cold water. In this operating mode, the system can simultaneously produce cold water and domestic hot water. Domestic hot water, in summer mode, is produced by heat recovery and therefore free of charge. When the temperature measured by the D.H.W. sensor reaches the set, the D.H.W. water pump is stopped and normal operation is restored in cooling mode. The operating modes are:

- 1. User water heating:** The unit behaves like a normal air/water heat pump in heating mode, using the finned heat exchanger as the source and the A plate heat exchanger as user.
- 2. User water cooling:** The unit behaves like a normal air/water chiller in cooling mode, using the finned heat exchanger as the source and the A plate heat exchanger as user.
- 3. Domestic hot water production (D.H.W.):** The unit behaves like a normal air / water heat pump in heating mode, using the finned heat exchanger as the source and as a user the plate heat exchanger B (a special D.H.W. heat exchanger that works with a higher set point).
- 4. User water cooling + D.H.W. production:** The unit behaves like a water / water heat pump, using the plate heat exchanger A as the cold user and the plate heat exchanger B as D.H.W. production).

### P4S VERSION

User water heating

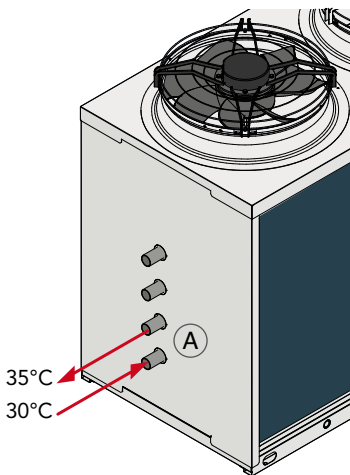

User water cooling

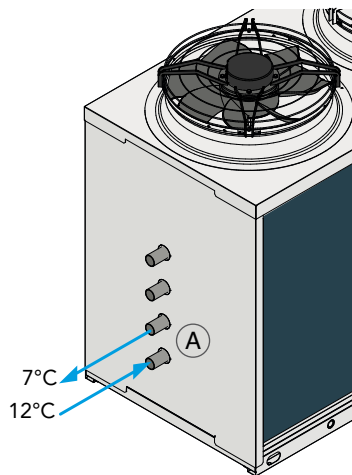

Domestic hot water production (D.H.W.)

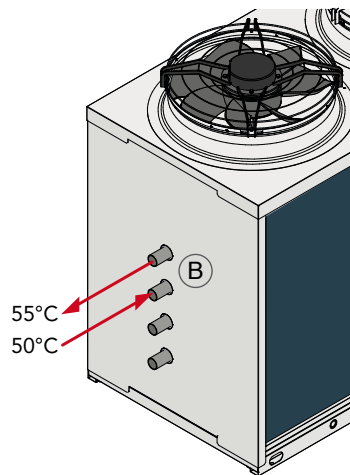

User water cooling + D.H.W. production

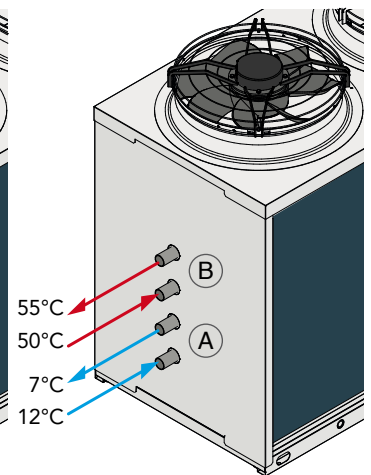

The above scheme is for illustrative purposes only. For the correct pipes placement, please refer to the units technical manual.

## ACCESSORIES

LHE/P4

LHE HA-HE /HH-RV		F1	F2	F3	F4	F5	F6	F7
Flow switch		●	●	●	●	●	●	●
Floating frame technology - LS version		-	-	-	-	-	-	-
Floating frame technology - XL version		●	●	●	●	●	●	●
Hydraulic kit with storage tank and one low-pressure pump	A1LLU	○	○	○	○	○	○	○
Hydraulic kit with one low-pressure pump for recovery circuit	A1LPR	○	○	○	○	○	○	○
Hydraulic kit with one low-pressure pump	A1LPU	○	○	○	○	○	○	○
Hydraulic kit with 1 pump - recovery circuit	A1NTR	○	○	○	○	○	○	○
Hydraulic kit with one pump without tank - user circuit	A1NTU	○	○	○	○	○	○	○
Hydraulic kit with inverter pump recovery circuit	A1VSR	-	-	-	-	-	○	○
User circuit hydraulic kit, one inverter pump, no tank	A1VSU	○	○	○	○	○	○	○
User circuit hydraulic kit + inverter centrifugal pump	A1VVU	○	○	○	○	○	○	○
Hydraulic kit with one pump with tank	A1ZZU	○	○	○	○	○	○	○
Hydraulic kit with 2 pumps - recovery circuit	A2NTR	○	○	○	○	○	○	○
Hydraulic kit with two pumps without tank - user circuit	A2NTU	○	○	○	○	○	○	○
Hydraulic kit with two pumps with tank	A2ZZU	○	○	○	○	○	○	○
Condensate discharge drip tray with antifreeze heater	BRCA	○	○	○	○	○	○	○
4-connection tank and low-pressure pump	BUF4A	○	○	○	○	○	○	○
Fans regulation by phase cut (HA version)	DCCF	●	●	●	●	●	●	●
Refrigerant leakage detector	DFR	●	●	●	●	●	●	●
Electronic soft starter	DSSE	○	○	○	○	○	○	○
Double safety valve	DSV	○	○	○	○	○	○	○
Coil protection grid	GBPE	○	○	○	○	○	○	○
WiFi Application	HIPRO.web	○	○	○	○	○	○	○
Display	HMI.PRO	●	●	●	●	●	●	●
Serial interface card RS485	INSE	●	●	●	●	●	●	●
Rubber vibration dampers	KAVG	○	○	○	○	○	○	○
Spring vibration dampers	KAVM	○	○	○	○	○	○	○
COP internal optimizer kit	KCOP	○	○	○	○	○	○	○
Lifting rings kit	KGS	●	●	●	●	●	●	●
Safety valve ducting aid kit	KCSV	●	●	●	●	●	●	●
Double safety valve ducting aid kit	KCDV	○	○	○	○	○	○	○
Antifreeze recovery kit	KPR	○	○	○	○	○	○	○
Tank antifreeze kit	KPSU	○	○	○	○	○	○	○
User antifreeze kit	KPU	○	○	○	○	○	○	○
Victaulic kit	KVICT	-	-	-	-*	●	●	●
Pressure gauges	MAML	○	○	○	○	○	○	○
Remote control panel	PCRL	○	○	○	○	○	○	○
Shut-off valve on compressor discharging side	RDCO	○	○	○	○	○	○	○
Master-slave control system	SGRS	○	○	○	○	○	○	○
DHW probe kit	SOND1	●	●	●	●	●	●	●
E.C. fans - HA versions	VECE	-	-	-	-	-	-	-
E.C. fans - HE versions	VECE	●	●	●	●	●	●	●
Electronic expansion valve	VTEE	●	●	●	●	●	●	●

● Standard ○ Optional – Not available

\* Standard for size 1792

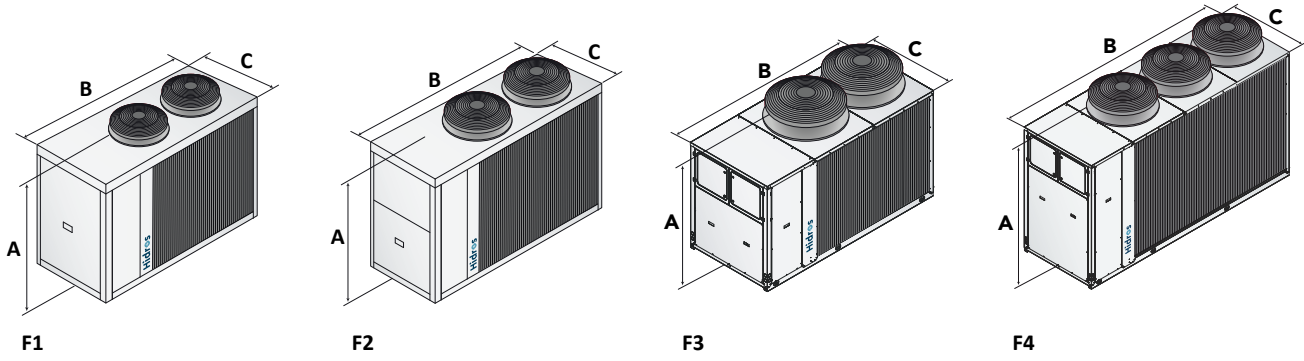

	452	512	682	752	912	1102	1152	1352	1502	1612
A (mm)	1673	1673	1839	1839	1918	1918	1918	1918	1918	1918
B (mm)	2400	2400	3000	3000	3000	3000	3000	4295	4295	4295
C (mm)	1265	1265	1265	1265	1265	1265	1265	1265	1265	1265
Kg	650	658	884	890	1100	1108	1110	1688	1714	1722
<b>FRAME</b>	<b>F1</b>	<b>F1</b>	<b>F2</b>	<b>F2</b>	<b>F3</b>	<b>F3</b>	<b>F3</b>	<b>F4</b>	<b>F4</b>	<b>F4</b>

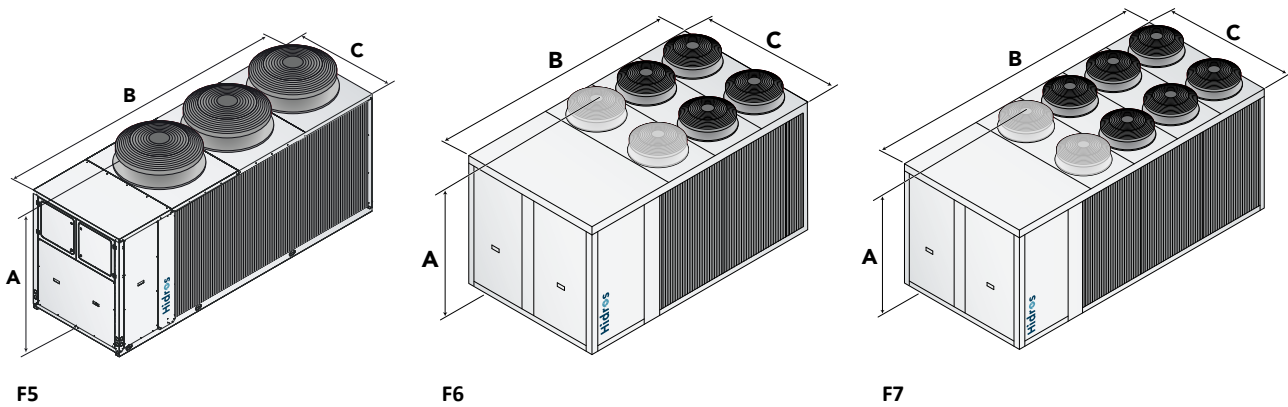

	1792	2012	2304	2312	2654	2954	3214	3514	3954	4454
A (mm)	1918	2287	2378	2287	2378	2378	2378	2378	2378	2378
B (mm)	4295	4296	4515	4296	4515	4515	4515	4515	5557	5557
C (mm)	1265	1265	2310	1265	2310	2310	2310	2310	2310	2310
Kg	1776	1762	1778	3262	3348	3438	3438	3508	3658	3686
<b>FRAME</b>	<b>F4</b>	<b>F5</b>	<b>F6</b>	<b>F5</b>	<b>F6</b>	<b>F6</b>	<b>F6</b>	<b>F6</b>	<b>F7</b>	<b>F7</b>

# LZT/P4

## 4 PIPE SYSTEMS HIGH EFFICIENCY AIR TO WATER HEAT PUMPS WITH E.V.I. COMPRESSORS

Heating power from 24 kW to 205 kW

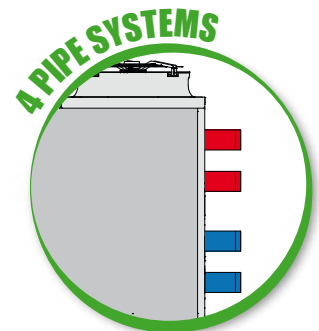
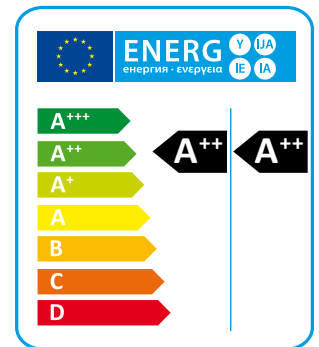

The high efficiency air / water heat pumps of the LZT/P4 series are units designed for 4-pipe air conditioning and heating systems, which allow the production of cold water for cooling and hot water for heating at the same time or separately.

The units are supplied with an additional exchanger, used as a condenser for hot water, the production of which is independent of the operation mode of the unit.

Activation of the exchanger takes place automatically via the microprocessor control when the hot water temperature on the return is lower than the set point. These units are able to produce hot water and cold water simultaneously and / or separately with very high energy efficiencies.

They are all supplied complete with a specific advanced microprocessor control provided with software for managing the various priorities.

The XL versions also have an extremely low noise level thanks to the use of a special floating vibration damping system that allows a noise reduction of about 6-8 dB (A) (optional).

### VERSIONS

- P4U** 4 pipe systems heating/cooling.
- P4S** 2+2 pipe systems with D.H.W. production.
- SA** Standard efficiency, AC fans.
- SE** Standard efficiency, EC fans.
- HA** High efficiency, AC fans.
- HE** High efficiency, EC fans.
- LS** Low noise.
- XL** Super low noise.
- NN** Ultra low noise.



## TECHNICAL DATA

SA/LS/RV - P4U/P4S		242	292	432	492	592	752	852
Heating capacity (EN14511) <sup>(1)</sup>	kW	23,7	28,3	42,1	50,9	55,0	67,8	74,5
Total input power (EN14511) <sup>(1)</sup>	kW	5,5	6,8	10,3	12,3	13,4	16,3	18,3
COP (EN14511) <sup>(1)</sup>	W/W	4,31	4,16	4,11	4,14	4,12	4,16	4,07
Energy Class in low temperature <sup>(2)</sup>		A+	A+	A+	A+	A+	A+	A+
SCOP low temperature <sup>(2)</sup>	kWh/kWh	3,75	3,77	3,39	3,33	3,49	3,70	3,62
η <sub>s,h</sub> low temperature <sup>(2)</sup>	%	147	148	133	130	137	145	142
Energy Class in medium temperature <sup>(2)</sup>		A+	A+	A+	A+	A+	A+	A+
SCOP medium temperature <sup>(2)</sup>	kWh/kWh	3,04	3,07	2,89	2,87	2,93	3,06	3,03
η <sub>s,h</sub> medium temperature <sup>(2)</sup>	%	119	120	112	112	114	119	118
Cooling capacity (EN14511) <sup>(3)</sup>	kW	22,5	29,5	36,4	46,1	53,6	61,6	74,3
Total input power (EN14511) <sup>(3)</sup>	kW	7,1	9,1	12,9	16,4	19,3	22,3	25,5
EER (EN14511) <sup>(3)</sup>	W/W	3,15	3,24	2,82	2,80	2,78	2,76	2,91
Sound power <sup>(4)</sup>	dB (A)	78	78	79	80	80	80	80
Sound pressure <sup>(5)</sup>	dB (A)	46	46	47	48	48	48	48
SE/LS/RV - P4U/P4S		242	292	432	492	592	752	852
Heating capacity (EN14511) <sup>(1)</sup>	kW	23,7	28,3	42,1	50,5	55,2	67,8	74,7
Total input power (EN14511) <sup>(1)</sup>	kW	5,3	6,7	9,9	12,8	13,8	16,1	18,2
COP (EN14511) <sup>(1)</sup>	W/W	4,47	4,22	4,25	3,95	4,00	4,21	4,10
Energy Class in low temperature <sup>(2)</sup>		A++	A++	A+	A+	A+	A+	A+
SCOP low temperature <sup>(2)</sup>	kWh/kWh	3,95	3,87	3,58	3,45	3,59	3,79	3,68
η <sub>s,h</sub> low temperature <sup>(2)</sup>	%	155	152	140	135	141	149	144
Energy Class in medium temperature <sup>(2)</sup>		A+	A+	A+	A+	A+	A+	A+
SCOP medium temperature <sup>(2)</sup>	kWh/kWh	3,17	3,13	3,02	2,99	3,02	3,13	3,10
η <sub>s,h</sub> medium temperature <sup>(2)</sup>	%	124	122	118	116	118	122	121
Cooling capacity (EN14511) <sup>(3)</sup>	kW	22,65	29,92	36,5	46,43	53,75	61,94	74,64
Total input power (EN14511) <sup>(3)</sup>	kW	7,1	9,0	12,8	16,2	19,2	21,9	25,4
EER (EN14511) <sup>(3)</sup>	W/W	3,19	3,32	2,86	2,86	2,81	2,83	2,94
Sound power <sup>(4)</sup>	dB (A)	78	78	79	80	80	80	80
Sound pressure <sup>(5)</sup>	dB (A)	46	46	47	48	48	48	48
Power supply	V/Ph/Hz	400/3+N/50	400/3+N/50	400/3/50	400/3/50	400/3/50	400/3/50	400/3/50
Compressors / Circuits	n° / n°	2 / 1	2 / 1	2 / 1	2 / 1	2 / 1	2 / 1	2 / 1
Fans	n°	1	1	2	2	2	2	2
Refrigerant		R410A	R410A	R410A	R410A	R410A	R410A	R410A
Refrigerant charge	kg	10,0	10,0	10,0	12,0	12,0	18,0	19,0
Global warming potential (GWP)		2088	2088	2088	2088	2088	2088	2088
Equivalent CO <sub>2</sub> charge	t	20,88	20,88	20,88	25,05	25,05	37,58	39,67
Water tank volume	l	100	100	100	100	100	300	300
SA/LS/RV - P4U/P4S		1002	1202	1454	1654	1854	2154	
Heating capacity (EN14511) <sup>(1)</sup>	kW	88,5	102,5	145,3	162,9	180,2	205,4	
Total input power (EN14511) <sup>(1)</sup>	kW	21,1	25,8	35,2	41,2	43,6	52,9	
COP (EN14511) <sup>(1)</sup>	W/W	4,21	3,98	4,13	3,96	4,13	3,88	
Energy Class in low temperature <sup>(2)</sup>		A+	A+	A+	A+	A+	A+	
SCOP low temperature <sup>(2)</sup>	kWh/kWh	3,61	3,60	3,44	3,42	3,43	3,42	
η <sub>s,h</sub> low temperature <sup>(2)</sup>	%	141	141	135	134	134	134	
Energy Class in medium temperature <sup>(2)</sup>		A+	A+	A+	A+	A+	A+	
SCOP medium temperature <sup>(2)</sup>	kWh/kWh	3,01	2,99	2,85	2,90	2,92	2,95	
η <sub>s,h</sub> medium temperature <sup>(2)</sup>	%	117	117	111	113	114	115	
Cooling capacity (EN14511) <sup>(3)</sup>	kW	77,9	90,4	125,8	142,0	155,1	177,9	
Total input power (EN14511) <sup>(3)</sup>	kW	26,9	32,6	44,1	51,7	55,3	68,6	
EER (EN14511) <sup>(3)</sup>	W/W	2,89	2,77	2,85	2,75	2,80	2,59	
Sound power <sup>(4)</sup>	dB (A)	80	80	87	87	88	89	
Sound pressure <sup>(5)</sup>	dB (A)	48	48	55	55	56	57	
SE/LS/RV - P4U/P4S		1002	1202	1454	1654	1854	2154	
Heating capacity (EN14511) <sup>(1)</sup>	kW	88,2	102,5	146,0	164,3	181,3	208,1	
Total input power (EN14511) <sup>(1)</sup>	kW	20,7	25,4	33,6	39,03	41,91	50,66	
COP (EN14511) <sup>(1)</sup>	W/W	4,26	4,03	4,35	4,21	4,33	4,11	
Energy Class in low temperature <sup>(2)</sup>		A+	A+	A+	A+	A+	A+	
SCOP low temperature <sup>(2)</sup>	kWh/kWh	3,69	3,70	3,63	3,57	3,69	3,63	
η <sub>s,h</sub> low temperature <sup>(2)</sup>	%	145	145	142	140	145	142	
Energy Class in medium temperature <sup>(2)</sup>		A+	A+	A+	A+	A+	A+	
SCOP medium temperature <sup>(2)</sup>	kWh/kWh	3,10	3,06	2,95	2,99	3,06	3,07	
η <sub>s,h</sub> medium temperature <sup>(2)</sup>	%	121	120	115	117	120	120	
Cooling capacity (EN14511) <sup>(3)</sup>	kW	78,1	90,9	126,4	143,1	156,3	179,3	
Total input power (EN14511) <sup>(3)</sup>	kW	25,0	32,1	41,7	49,5	53,5	66,1	
EER (EN14511) <sup>(3)</sup>	W/W	3,13	2,83	3,03	2,89	2,92	2,71	
Sound power <sup>(4)</sup>	dB (A)	80	80	86	87	88	89	
Sound pressure <sup>(5)</sup>	dB (A)	48	48	54	55	56	57	
Power supply	V/Ph/Hz	400/3/50	400/3/50	400/3/50	400/3/50	400/3/50	400/3/50	
Compressors / Circuits	n° / n°	2 / 1	2 / 1	4/2	4/2	4/2	4/2	
Fans	n°	3	4	4	4	4	4	
Refrigerant		R410A	R410A	R410A	R410A	R410A	R410A	
Refrigerant charge	kg	23,0	23,0	45,0	45,0	50,0	50,0	
Global warming potential (GWP)		2088	2088	2088	2088	2088	2088	
Equivalent CO <sub>2</sub> charge	t	48,02	48,02	93,96	93,96	104,40	104,40	
Water tank volume	l	300	300	500	500	500	500	

Performances are referred to the following conditions:

(1) Heating: Ambient temperature 7°C DB, 6°C WB, water temperature 30/35°C.

(2) Average conditions, variable - Reg EU 811/2013

(3) Cooling: ambient air temperature 35°C, evaporator water temperature in/out 12/7 °C.

(4) Sound power level in accordance with ISO 3744..

(5) Sound pressure level at 10 mt from the unit in free field conditions in accordance with ISO 3744.

HA/LS/RV - P4U/P4S		242	292	432	492	602	752	852
Heating capacity (EN14511) <sup>(1)</sup>	kW	23,8	29,4	41,6	51,2	58,0	66,7	80,8
Total input power (EN14511) <sup>(1)</sup>	kW	5,3	6,8	9,7	12,4	13,0	15,6	19,6
COP (EN14511) <sup>(1)</sup>	W/W	4,51	4,31	4,29	4,12	4,45	4,29	4,13
Energy Class in low temperature <sup>(2)</sup>		A++	A++	A+	A+	A++	A++	A+
SCOP low temperature <sup>(2)</sup>	kWh/kWh	3,96	3,89	3,63	3,55	3,94	3,95	3,76
η <sub>s,h</sub> low temperature <sup>(2)</sup>	%	155	153	142	139	155	155	147
Energy Class in medium temperature <sup>(2)</sup>		A+	A+	A+	A+	A++	A+	A+
SCOP medium temperature <sup>(2)</sup>	kWh/kWh	3,18	3,15	2,99	2,98	3,21	3,16	3,01
η <sub>s,h</sub> medium temperature <sup>(2)</sup>	%	124	123	117	116	126	123	117
Cooling capacity (EN14511) <sup>(3)</sup>	kW	22,9	30,1	37,5	46,7	52,8	62,5	71,6
Total input power (EN14511) <sup>(3)</sup>	kW	7,0	9,0	12,7	16,1	18,1	21,6	24,6
EER (EN14511) <sup>(3)</sup>	W/W	3,25	3,36	2,97	2,90	2,91	2,89	2,91
Sound power <sup>(4)</sup>	dB (A)	78	78	78	79	80	80	83
Sound pressure <sup>(5)</sup>	dB (A)	46	46	46	47	48	48	51
HE/LS/RV - P4U/P4S		242	292	432	492	602	752	852
Heating capacity (EN14511) <sup>(1)</sup>	kW	24,0	29,5	41,8	50,3	58,3	66,9	81,3
Total input power (EN14511) <sup>(1)</sup>	kW	5,2	6,7	9,5	12,2	12,8	15,3	18,9
COP (EN14511) <sup>(1)</sup>	W/W	4,61	4,38	4,40	4,12	4,56	4,37	4,31
Energy Class in low temperature <sup>(2)</sup>		A++	A++	A++	A++	A++	A++	A++
SCOP low temperature <sup>(2)</sup>	kWh/kWh	4,10	3,96	3,87	3,83	4,08	4,06	3,83
η <sub>s,h</sub> low temperature <sup>(2)</sup>	%	161	156	152	150	160	159	150
Energy Class in medium temperature <sup>(2)</sup>		A++	A++	A+	A+	A++	A++	A+
SCOP medium temperature <sup>(2)</sup>	kWh/kWh	3,25	3,21	3,12	3,15	3,29	3,23	3,07
η <sub>s,h</sub> medium temperature <sup>(2)</sup>	%	127	125	122	123	129	126	120
Cooling capacity (EN14511) <sup>(3)</sup>	kW	22,9	30,2	37,5	45,6	52,9	62,5	71,6
Total input power (EN14511) <sup>(3)</sup>	kW	7,0	8,8	12,7	16,7	17,9	21,3	24,4
EER (EN14511) <sup>(3)</sup>	W/W	3,27	3,42	2,96	2,73	2,95	2,64	2,94
Sound power <sup>(4)</sup>	dB (A)	78	78	78	79	80	80	83
Sound pressure <sup>(5)</sup>	dB (A)	46	46	46	47	48	48	51
Power supply	V/Ph/Hz	400/3+N/50	400/3+N/50	400/3/50	400/3/50	400/3/50	400/3/50	400/3/50
Compressors / Circuits	n° / n°	2 / 1	2 / 1	2 / 1	2 / 1	2 / 1	2 / 1	2 / 1
Fans	n°	1	1	2	2	2	2	2
Refrigerant		R410A	R410A	R410A	R410A	R410A	R410A	R410A
Refrigerant charge	kg	10,0	10,0	14,5	12,0	18,0	23,0	23,0
Global warming potential (GWP)		2088	2088	2088	2088	2088	2088	2088
Equivalent CO <sub>2</sub> charge	t	20,88	20,88	30,27	25,05	37,58	48,02	48,02
Water tank volume	l	100	100	100	100	300	300	300

HA/LS/RV - P4U/P4S		1002	1202	1454	1654	1854	2154
Heating capacity (EN14511) <sup>(1)</sup>	kW	88,4	102,5	145,6	163,7	181,9	210,2
Total input power (EN14511) <sup>(1)</sup>	kW	21,4	25,3	35,2	40,7	43,8	52,2
COP (EN14511) <sup>(1)</sup>	W/W	4,13	4,05	4,14	4,02	4,16	4,02
Energy Class in low temperature <sup>(2)</sup>		A+	A+	A+	A+	A+	A+
SCOP low temperature <sup>(2)</sup>	kWh/kWh	3,80	3,78	3,74	3,65	3,79	3,78
η <sub>s,h</sub> low temperature <sup>(2)</sup>	%	149	148	147	143	149	148
Energy Class in medium temperature <sup>(2)</sup>		A+	A+	A+	A+	A+	A+
SCOP medium temperature <sup>(2)</sup>	kWh/kWh	3,05	3,06	3,05	3,03	3,12	3,16
η <sub>s,h</sub> medium temperature <sup>(2)</sup>	%	119	120	119	118	122	123
Cooling capacity (EN14511) <sup>(3)</sup>	kW	78,1	90,2	127,4	143,5	157,8	180,9
Total input power (EN14511) <sup>(3)</sup>	kW	26,6	32,2	42,4	50,8	53,6	66,5
EER (EN14511) <sup>(3)</sup>	W/W	2,94	2,80	3,01	2,82	2,94	2,72
Sound power <sup>(4)</sup>	dB (A)	83	83	84	85	85	85
Sound pressure <sup>(5)</sup>	dB (A)	51	51	52	53	53	53
HE/LS/RV - P4U/P4S		1002	1202	1454	1654	1854	2154
Heating capacity (EN14511) <sup>(1)</sup>	kW	88,5	102,7	145,2	163,2	181,3	209,6
Total input power (EN14511) <sup>(1)</sup>	kW	20,6	24,6	33,4	38,9	41,9	50,5
COP (EN14511) <sup>(1)</sup>	W/W	4,31	4,17	4,35	4,19	4,33	4,15
Energy Class in low temperature <sup>(2)</sup>		A++	A++	A++	A++	A++	A++
SCOP low temperature <sup>(2)</sup>	kWh/kWh	3,85	3,84	3,88	3,88	3,89	3,89
η <sub>s,h</sub> low temperature <sup>(2)</sup>	%	151	151	152	152	153	153
Energy Class in medium temperature <sup>(2)</sup>		A+	A+	A+	A+	A+	A+
SCOP medium temperature <sup>(2)</sup>	kWh/kWh	3,14	3,13	3,10	3,15	3,17	3,19
η <sub>s,h</sub> medium temperature <sup>(2)</sup>	%	123	122	121	123	124	124
Cooling capacity (EN14511) <sup>(3)</sup>	kW	78,2	90,8	126,8	142,8	157,0	180,1
Total input power (EN14511) <sup>(3)</sup>	kW	26,1	31,3	42,0	50,5	53,4	66,2
EER (EN14511) <sup>(3)</sup>	W/W	3,00	2,90	3,02	2,83	2,94	2,72
Sound power <sup>(4)</sup>	dB (A)	83	83	84	85	85	85
Sound pressure <sup>(5)</sup>	dB (A)	51	51	52	53	53	53
Power supply	V/Ph/Hz	400/3/50	400/3/50	400/3/50	400/3/50	400/3/50	400/3/50
Compressors / Circuits	n° / n°	2 / 1	2 / 1	4/2	4/2	4/2	4/2
Fans	n°	2	2	3	3	3	3
Refrigerant		R410A	R410A	R410A	R410A	R410A	R410A
Refrigerant charge	kg	27,0	27,0	45,0	45,0	50,0	50,0
Global warming potential (GWP)		2088	2088	2088	2088	2088	2088
Equivalent CO <sub>2</sub> charge	t	56,37	56,37	93,96	93,96	104,40	104,40
Water tank volume	l	300	300	500	500	500	500

Performances are referred to the following conditions:

(1) Heating: Ambient temperature 7°C DB, 6°C WB, water temperature 30/35°C.

(2) Average conditions, variable - Reg EU 811/2013

(3) Cooling: ambient air temperature 35°C, evaporator water temperature in/out 12/7 °C.

(4) Sound power level in accordance with ISO 3744..

(5) Sound pressure level at 10 mt from the unit in free field conditions in accordance with ISO 3744.

HA/XL/RV - P4U/P4S		252	302	432	492	602	752	852
Heating capacity (EN14511) <sup>(1)</sup>	kW	24,0	29,6	41,1	48,9	57,4	65,5	80,1
Total input power (EN14511) <sup>(1)</sup>	kW	5,5	7,0	9,5	12,1	12,9	15,2	18,4
COP (EN14511) <sup>(1)</sup>	W/W	4,40	4,24	4,35	4,04	4,46	4,31	4,35
Energy Class in low temperature <sup>(2)</sup>		A++	A++	A++	A++	A++	A++	A++
SCOP low temperature <sup>(2)</sup>	kWh/kWh	3,83	3,84	3,84	3,83	4,03	4,01	3,83
$\eta_{s,h}$ low temperature <sup>(2)</sup>	%	150	151	151	150	158	158	150
Energy Class in medium temperature <sup>(2)</sup>		A+	A+	A+	A+	A++	A+	A+
SCOP medium temperature <sup>(2)</sup>	kWh/kWh	3,05	3,13	3,11	3,14	3,27	3,20	3,13
$\eta_{s,h}$ medium temperature <sup>(2)</sup>	%	119	122	121	122	128	125	122
Cooling capacity (EN14511) <sup>(3)</sup>	kW	22,0	28,3	36,8	45,5	52,1	62,0	71,2
Total input power (EN14511) <sup>(3)</sup>	kW	7,1	9,1	13,2	16,1	18,9	21,9	23,7
EER (EN14511) <sup>(3)</sup>	W/W	3,10	3,13	2,78	2,82	2,75	2,83	3,00
Sound power <sup>(4)</sup>	dB (A)	72	72	73	74	74	74	74
Sound pressure <sup>(5)</sup>	dB (A)	40	40	41	42	42	42	42
HE/XL/RV - P4U/P4S		252	302	432	492	602	752	852
Heating capacity (EN14511) <sup>(1)</sup>	kW	24,0	30,0	41,2	49,2	57,4	65,6	79,9
Total input power (EN14511) <sup>(1)</sup>	kW	5,2	6,8	9,2	11,8	12,6	15,1	17,8
COP (EN14511) <sup>(1)</sup>	W/W	4,64	4,39	4,49	4,16	4,57	4,35	4,49
Energy Class in low temperature <sup>(2)</sup>		A++	A++	A++	A++	A++	A++	A++
SCOP low temperature <sup>(2)</sup>	kWh/kWh	4,10	3,87	4,00	3,84	4,21	4,16	4,04
$\eta_{s,h}$ low temperature <sup>(2)</sup>	%	161	152	157	151	165	163	159
Energy Class in medium temperature <sup>(2)</sup>		A++	A+	A++	A++	A++	A++	A++
SCOP medium temperature <sup>(2)</sup>	kWh/kWh	3,24	3,14	3,24	3,16	3,38	3,29	3,26
$\eta_{s,h}$ medium temperature <sup>(2)</sup>	%	127	123	127	123	132	129	127
Cooling capacity (EN14511) <sup>(3)</sup>	kW	21,0	28,9	37,2	45,7	52,0	62,1	70,6
Total input power (EN14511) <sup>(3)</sup>	kW	7,0	9,1	12,7	16,0	18,8	21,8	24,2
EER (EN14511) <sup>(3)</sup>	W/W	2,98	3,17	2,93	2,85	2,78	2,85	2,92
Sound power <sup>(4)</sup>	dB (A)	71	72	73	74	73	73	74
Sound pressure <sup>(5)</sup>	dB (A)	39	40	41	42	41	41	42
Power supply	V/Ph/Hz	400/3+N/50	400/3+N/50	400/3/50	400/3/50	400/3/50	400/3/50	400/3/50
Compressors / Circuits	n° / n°	2 / 1	2 / 1	2 / 1	2 / 1	2 / 1	2 / 1	2 / 1
Fans	n°	2	2	2	2	2	2	2
Refrigerant		R410A	R410A	R410A	R410A	R410A	R410A	R410A
Refrigerant charge	kg	10,0	10,0	14,5	12,0	18,0	23,0	23,0
Global warming potential (GWP)		2088	2088	2088	2088	2088	2088	2088
Equivalent CO <sub>2</sub> charge	t	20,88	20,88	30,27	25,05	37,58	48,02	48,02
Water tank volume	l	100	100	100	100	300	300	300

HA/XL/RV - P4U/P4S		1002	1202	1454	1654	1854	2154
Heating capacity (EN14511) <sup>(1)</sup>	kW	87,3	100,7	147,8	166,9	187,4	218,2
Total input power (EN14511) <sup>(1)</sup>	kW	20,0	23,8	33,5	38,7	43,1	51,3
COP (EN14511) <sup>(1)</sup>	W/W	4,37	4,23	4,41	4,31	4,35	4,25
Energy Class in low temperature <sup>(2)</sup>		A++	A++	A++	A++	A++	A++
SCOP low temperature <sup>(2)</sup>	kWh/kWh	3,91	3,84	3,93	3,90	3,88	3,88
$\eta_{s,h}$ low temperature <sup>(2)</sup>	%	153	151	154	153	152	152
Energy Class in medium temperature <sup>(2)</sup>		A++	A+	A+	A+	A+	A+
SCOP medium temperature <sup>(2)</sup>	kWh/kWh	3,21	3,18	3,16	3,17	3,10	3,13
$\eta_{s,h}$ medium temperature <sup>(2)</sup>	%	126	124	123	124	121	122
Cooling capacity (EN14511) <sup>(3)</sup>	kW	77,1	88,7	126,6	143,4	158,7	184,3
Total input power (EN14511) <sup>(3)</sup>	kW	26,2	32,6	40,9	48,1	49,7	61,3
EER (EN14511) <sup>(3)</sup>	W/W	2,95	2,72	3,10	2,98	3,19	3,01
Sound power <sup>(4)</sup>	dB (A)	75	75	79	79	80	80
Sound pressure <sup>(5)</sup>	dB (A)	43	43	47	47	48	48
HE/XL/RV - P4U/P4S		1002	1202	1454	1654	1854	2154
Heating capacity (EN14511) <sup>(1)</sup>	kW	87,2	100,7	147,6	166,6	187,6	218,2
Total input power (EN14511) <sup>(1)</sup>	kW	19,4	23,5	32,3	37,6	41,2	49,5
COP (EN14511) <sup>(1)</sup>	W/W	4,49	4,29	4,57	4,43	4,55	4,41
Energy Class in low temperature <sup>(2)</sup>		A++	A++	A++	A++	A++	A++
SCOP low temperature <sup>(2)</sup>	kWh/kWh	4,06	3,93	4,10	4,00	3,94	3,92
$\eta_{s,h}$ low temperature <sup>(2)</sup>	%	160	154	161	157	154	154
Energy Class in medium temperature <sup>(2)</sup>		A++	A++	A++	A++	A++	A++
SCOP medium temperature <sup>(2)</sup>	kWh/kWh	3,33	3,25	3,28	3,29	3,28	3,28
$\eta_{s,h}$ medium temperature <sup>(2)</sup>	%	130	127	128	129	128	128
Cooling capacity (EN14511) <sup>(3)</sup>	kW	76,9	88,1	126,5	142,7	158,7	184,3
Total input power (EN14511) <sup>(3)</sup>	kW	26,3	32,9	40,3	48,4	49,7	60,3
EER (EN14511) <sup>(3)</sup>	W/W	2,92	2,68	3,14	2,95	3,19	3,05
Sound power <sup>(4)</sup>	dB (A)	75	75	79	79	80	80
Sound pressure <sup>(5)</sup>	dB (A)	43	43	47	47	48	48
Power supply	V/Ph/Hz	400/3/50	400/3/50	400/3/50	400/3/50	400/3/50	400/3/50
Compressors / Circuits	n° / n°	2 / 1	2 / 1	4 / 2	4 / 2	4 / 2	4 / 2
Fans	n°	2	2	4	4	6	6
Refrigerant		R410A	R410A	R410A	R410A	R410A	R410A
Refrigerant charge	kg	27,0	27,0	50,0	50,0	55,0	55,0
Global warming potential (GWP)		2088	2088	2088	2088	2088	2088
Equivalent CO <sub>2</sub> charge	t	56,37	56,37	104,40	104,40	114,84	114,84
Water tank volume	l	300	300	500	500	500	500

Performances are referred to the following conditions:

(1) Heating: Ambient temperature 7°C DB, 6°C WB, water temperature 30/35°C.

(2) Average conditions, variable - Reg EU 811/2013

(3) Cooling: ambient air temperature 35°C, evaporator water temperature in/out 12/7 °C.

(4) Sound power level in accordance with ISO 3744..

(5) Sound pressure level at 10 mt from the unit in free field conditions in accordance with ISO 3744.

HE/NN/RV - P4U/P4S		252	312	452	502	602	752	852
Heating capacity (EN14511) <sup>(1)</sup>	kW	23,4	30,5	41,1	54,2	60,7	70,4	79,5
Total input power (EN14511) <sup>(1)</sup>	kW	5,0	6,4	8,8	11,7	12,4	14,7	17,41
COP (EN14511) <sup>(1)</sup>	W/W	4,69	4,75	4,69	4,64	4,89	4,78	4,56
Energy Class in low temperature <sup>(2)</sup>		A++	A++	A++	A++	A++	A++	A++
SCOP low temperature <sup>(2)</sup>	kWh/kWh	4,30	4,35	4,23	4,10	4,37	4,40	4,22
$\eta_{s,h}$ low temperature <sup>(2)</sup>	%	169	171	166	161	172	173	166
Energy Class in medium temperature <sup>(2)</sup>		A++	A++	A++	A++	A++	A++	A++
SCOP medium temperature <sup>(2)</sup>	kWh/kWh	3,34	3,48	3,42	3,34	3,47	3,45	3,38
$\eta_{s,h}$ medium temperature <sup>(2)</sup>	%	131	136	134	131	136	135	132
Cooling capacity (EN14511) <sup>(3)</sup>	kW	22,1	28,5	37,0	46,4	53,3	61,6	72,9
Total input power (EN14511) <sup>(3)</sup>	kW	6,9	9,1	12,6	14,9	16,8	20,9	25,1
EER (EN14511) <sup>(3)</sup>	W/W	3,20	3,15	2,93	3,11	3,18	2,95	2,90
Sound power <sup>(4)</sup>	dB (A)	68	69	71	71	71	72	72
Sound pressure <sup>(5)</sup>	dB (A)	36	37	39	39	39	40	40
Power supply	V/Ph/Hz	400/3+N/50	400/3/50	400/3/50	400/3/50	400/3/50	400/3/50	400/3/50
Compressors / Circuits	n° / n°	2 / 1	2 / 1	2 / 1	2 / 1	2 / 1	2 / 1	2 / 1
Fans	n°	2	2	2	2	2	2	2
Refrigerant		R410A	R410A	R410A	R410A	R410A	R410A	R410A
Refrigerant charge	kg	10,0	10,0	18,0	23,0	18,0	23,0	23,0
Global warming potential (GWP)		2088,0	2088	2088	2088	2088	2088	2088
Equivalent CO <sub>2</sub> charge	t	20,88	20,88	37,58	48,02	37,58	48,02	48,02

HE/NN/RV - P4U/P4S		1002	1202	1454	1654	1854	2154
Heating capacity (EN14511) <sup>(1)</sup>	kW	90,3	104,9	146,7	165,1	184,7	214,0
Total input power (EN14511) <sup>(1)</sup>	kW	18,6	22,1	31,5	36,6	40,0	48,0
COP (EN14511) <sup>(1)</sup>	W/W	4,87	4,75	4,66	4,51	4,62	4,46
Energy Class in low temperature <sup>(2)</sup>		A++	A++	A++	A++	A++	A++
SCOP low temperature <sup>(2)</sup>	kWh/kWh	4,42	4,31	4,31	4,15	4,23	4,12
$\eta_{s,h}$ low temperature <sup>(2)</sup>	%	174	169	169	163	166	162
Energy Class in medium temperature <sup>(2)</sup>		A++	A++	A++	A++	A++	A++
SCOP medium temperature <sup>(2)</sup>	kWh/kWh	3,52	3,50	3,41	3,40	3,47	3,42
$\eta_{s,h}$ medium temperature <sup>(2)</sup>	%	138	137	134	133	136	134
Cooling capacity (EN14511) <sup>(3)</sup>	kW	79,0	91,9	124,7	139,5	156,5	179,9
Total input power (EN14511) <sup>(3)</sup>	kW	24,7	29,8	41,5	50,9	50,8	63,3
EER (EN14511) <sup>(3)</sup>	W/W	3,20	3,08	3,01	2,74	3,08	2,84
Sound power <sup>(4)</sup>	dB (A)	72	72	74	74	75	75
Sound pressure <sup>(5)</sup>	dB (A)	40	40	42	42	43	43
Power supply	V/Ph/Hz	400/3/50	400/3/50	400/3/50	400/3/50	400/3/50	400/3/50
Compressors / Circuits	n° / n°	2 / 1	2 / 1	4/2	4/2	4/2	4/2
Fans	n°	3	3	4	4	6	6
Refrigerant		R410A	R410A	R410A	R410A	R410A	R410A
Refrigerant charge	kg	36,0	36,0	50,0	50,0	55,0	55,0
Global warming potential (GWP)		2088	2088	2088	2088	2088	2088
Equivalent CO <sub>2</sub> charge	t	75,16	75,16	104,40	104,40	114,84	114,84

Performances are referred to the following conditions:

(1) Heating: Ambient temperature 7°C DB, 6°C WB, water temperature 30/35°C.

(2) Average conditions, variable - Reg EU 811/2013

(3) Cooling: ambient air temperature 35°C, evaporator water temperature in/out 12/7 °C.

(4) Sound power level in accordance with ISO 3744..

(5) Sound pressure level at 10 mt from the unit in free field conditions in accordance with ISO 3744.

## COMPONENTS

### FRAME

All units are made from hot-galvanised sheet steel, painted with polyurethane powder enamel and stoved at 180°C to provide maximum protection against corrosion. The frame is self-supporting with removable panels. All screws and rivets used are made from stainless steel.

The standard colour of the units is RAL9018.

### REFRIGERANT CIRCUIT

The refrigerant utilised is R410A. The refrigerant circuit is assembled using internationally recognised brand name components with all brazing and welding being performed in accordance with ISO 97/23. The refrigerant circuit includes: sight glass, filter drier, two thermal expansion valves (one for cooling mode, one for heating mode) with external equalizer, 4 way reversing valve, check valves, liquid receiver, Schrader valves for maintenance and control, pressure safety device (for compliance with PED regulations). The circuit also includes an AISI316 stainless steel heat exchanger that is used as an economizer plus an additional expansion valve for refrigerant vapour injection.

### COMPRESSORS

Units use scroll compressors that are equipped with E.V.I. technology, a versatile method of improving system capacity and efficiency. EVI stands for "Enhanced Vapour Injection." The technology involves injecting refrigerant vapour into the middle of the compression process, a procedure that significantly boosts capacity and efficiency. Each scroll compressor used in these units is similar to a two-stage compressor with built-in inter-stage cooling. The process begins when a portion of the condenser liquid is extracted and expanded through an expansion valve. The low temperature liquid/gas mixture produced is injected into a heat exchanger that operates as a sub cooler. Any liquid is evaporated and the vapour produced is superheated.

The superheated vapour is then injected into an intermediate port in the scroll compressor. This cold vapour reduces the temperature of the compressed gas thus enabling the compressor to raise the pressure to levels (and temperatures) beyond that possible with a single stage scroll. The additional sub cooling of the main volume of liquid refrigerant increases the evaporator capacity. This compressor technology generates a larger pressure ratio between condensing and evaporating pressures, with significant performance improvement. In all units the compressors are connected in tandem. The compressors are all supplied with a crankcase heater and thermal overload protection by a klixon embedded in the motor winding. They are mounted in a separate enclosure in order to be separated from the air stream thus enabling them to be maintained even if the unit is operating. Access to this enclosure is by the front panel of the unit. The crankcase heater is always powered when the compressor is in stand-by.

### SOURCE HEAT EXCHANGER

The source heat exchanger is made from copper pipes and aluminium fins. Dimensioning of the copper pipes and the aluminium wings is optimized in order to obtain excellent performance. The tubes are mechanically expanded into the fins in order to maximise heat transfer. Furthermore, the design guarantees a low air side pressure drop thus enabling the use of low rotation speed (and hence low noise) fans. All heat exchangers are supplied standard with fins hydrophilic coating.

### USER HEAT EXCHANGERS

The user heat exchanger is a braze welded, plate type heat exchanger, manufactured from AISI 316 stainless steel. The use of this type of exchanger results in a massive reduction of the refrigerant charge of the unit compared to a traditional shell-in-tube type. A further advantage is a reduction in the overall dimensions of the unit.

The exchangers are factory insulated with flexible close cell

material and can be fitted with an antifreeze heater (accessory). Each exchanger is fitted with a temperature sensor on the discharge water side for antifreeze protection.

### FANS

The fans are direct drive axial type with aluminium aerofoil blades, are statically and dynamically balanced and are supplied complete with a safety fan guard complying with the requirements of EN 60335. They are fixed to the unit frame via rubber antivibration mountings. In the LS versions the fans are 6 poles type (approx 900 rpm), in the XL versions the fans are 8 poles type (approx 600 rpm), in the NN versions the fans are 12 poles type (approx 450 rpm). The motors are fitted with integrated thermal overload protection and have a moisture protection rating of IP 54.

### MICROPROCESSORS

All units are supplied as standard complete with control panel. The microprocessor controls the following functions: control of the water temperature, antifreeze protection, compressor timing, compressor automatic starting sequence (For multiple compressors), alarm reset.

The control panel is supplied with display showing all operational icons. The microprocessor is set for automatic defrost (when operating in severe ambient conditions) and for summer/ winter change over (only for RV versions).

The control also manages the anti-legionella program, the integration with other heating sources (electric heaters, boilers, solar panels etc), the operation of a three port modulating valve (for diverting to DHW or heating) and both the heating circuit pump and the domestic hot water circuit pump. If required (available as an option), the microprocessor can be configured in order for it to connect to a site BMS system thus enabling remote control and management.

### ELECTRIC ENCLOSURE

The enclosure is manufactured in order to comply with the requirements of the electromagnetic compatibility standards CEE EN60204. Access to electrical cabinet in quick and easy thanks to hinged panels. The following components are supplied as standard on all units: main switch, a sequence relay that disables the power supply in the event that the phase sequence is incorrect (scroll compressors can be damaged if they rotate in the wrong direction), thermal overloads (protection of pumps and fans), compressor fuses, control circuit automatic breakers, compressor contactors, fan contactors and pump contactors. The terminal board has volt free contacts for remote ON-OFF, Summer/ winter change over (heat pumps only) and general alarm.

### CONTROL AND PROTECTION DEVICES

All units are supplied with the following controls and protections: user water return temperature sensor, antifreeze protection temperature sensor installed on users water output, domestic hot water supply and return temperature sensors (only versions P2S), high pressure manual reset, low pressure automatic reset, compressor thermal protection, air fan, thermal protection, pressure transducer (used to optimize the defrost cycle and to adjust the fan speed depending on ambient conditions), flow switch. All units are also fitted with a temperature probe sensor with "Energy Saving" function, supplied in a separate plastic box, which can be used to stop the pump use during periods of stand-by, when the water temperature reaches the set point. Doing this the power consumption of the unit is strongly reduced. The probe sensor must be positioned in the hydraulic compensator present at the screening technique. The domestic hot water circuit (only versions P2S) is already equipped with this probe, but it must be installed in the user circuit.

## OPERATION LIMITS

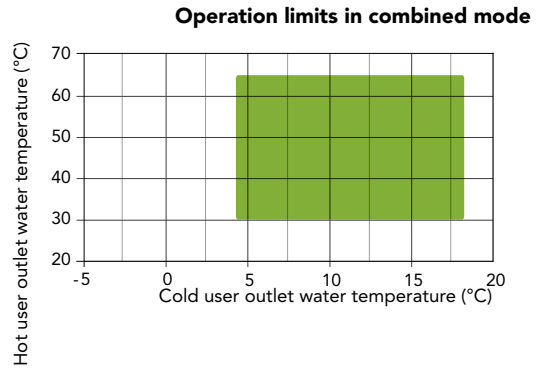
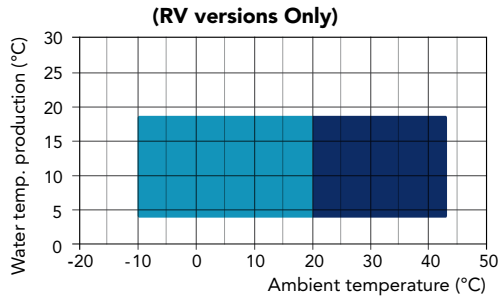
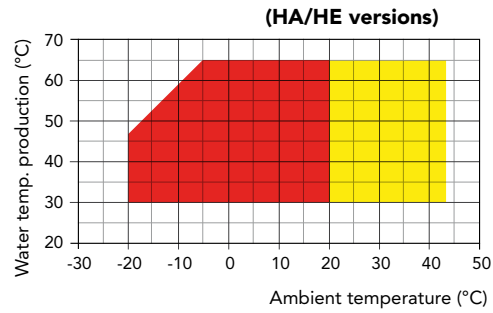
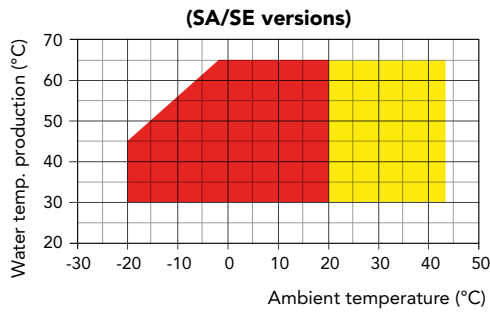

- Heating mode
- Heating mode with head pressure control (DCCF)
- Cooling with head pressure control (DCCF)

- Cooling mode
- Combined mode

## VERSIONS

### P4U version

The P4U units use 4 hydraulic connections and are used in modern 4-pipe systems. In these systems, cold and hot water is always available (in every period of the year) and present in the specific hydraulic circuit.

These systems allow the simultaneous production of cold water and hot water using 4 hydraulic connections, 2 connections are related to the hot water circuit, 2 connections are related to the cold water circuit.

The plant thus conceived is able to heat and, at the same time, if required, to cool with very high energy efficiencies. In this configuration, however, the units are also able to produce hot or cold water separately at any time of the year.

The units are supplied with 2 heat exchangers, one dedicated to the production of cold water and one dedicated to the production of hot water.

The operating modes are:

**1. User water heating:** The unit behaves like a normal air/water heat pump in heating mode, using the finned heat exchanger as the source and the A plate heat exchanger as user.

**2. User water cooling:** The unit behaves like a normal air / water chiller in cooling mode, using the finned exchanger as the source and the B plate heat exchanger as user.

**3. Simultaneous user Cooling + heating:** The unit behaves like a water / water heat pump, using the plate heat exchanger B as the cold user and the plate heat exchanger A as hot user. This version is not able to produce domestic hot water.

### P4S Version

The P4S units have been designed to meet the needs of 2 + 2 pipe systems (2 user side pipes, 2 domestic hot water pipes) throughout the year. The units are supplied with 2 exchangers, one dedicated to the production of the user cold and hot water and one dedicated to the production of domestic hot water only (D.H.W.). The production of domestic hot water always has priority. In winter mode the activation of D.H.W. production temporarily stops the production of the user hot water, which is re-

## P4U VERSION

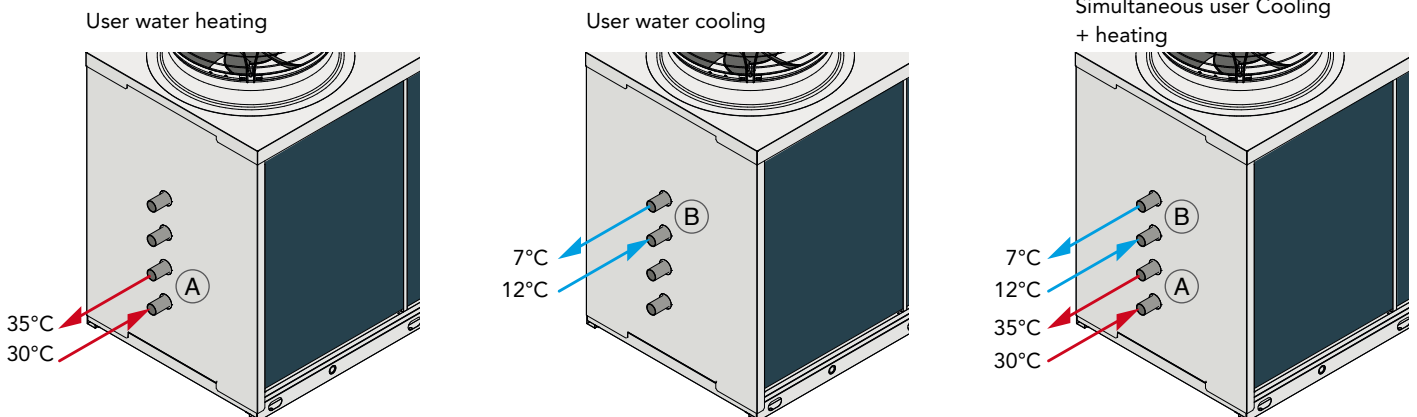

The above scheme is for illustrative purposes only. For the correct pipes placement, please refer to the units technical manual.

stored when the D.H.W. accumulation reaches the temperature set. In summer mode the unit will switch to cooling (by activating the reverse cycle valve installed in the refrigerant circuit) and any request for domestic hot water will allow, at the same time, the production of cold water. In this operating mode, the system can simultaneously produce cold water and domestic hot water. Domestic hot water, in summer mode, is produced by heat recovery and therefore free of charge. When the temperature measured by the D.H.W. sensor reaches the set, the D.H.W. water pump is stopped and normal operation is restored in cooling mode.

The operating modes are:

**1. User water heating:** The unit behaves like a normal air/water heat pump in heating mode, using the finned heat exchanger as the source and the A plate heat exchanger as user.

**2. User water cooling:** The unit behaves like a normal air/water chiller in cooling mode, using the finned heat exchanger as the source and the A plate heat exchanger as user.

**3. Domestic hot water production (D.H.W.):** The unit behaves like a normal air / water heat pump in heating mode, using the finned heat exchanger as the source and as a user the plate heat exchanger B (a special D.H.W. heat exchanger that works with a higher set point).

**4. User water cooling + D.H.W. production:** The unit behaves like a water / water heat pump, using the plate heat exchanger A as the cold user and the plate heat exchanger B as D.H.W. production).

**SA Version**

Standard efficiency version, according to current standard. Unit equipped with AC fans.

**SE Version**

Standard efficiency version, according to current standard. Unit equipped with EC fans.

**HA Version**

High efficiency version, according to current standard. Unit equipped with AC fans.

**HE Version**

High efficiency version, according to current standard. Unit equipped with EC fans.

**Version LS**

This version includes the complete acoustic insulation of the unit with compressor jackets and insulating material made with high density media and the interposition of heavy bitumen layer.

**Super low noise and ultra low noise versions XL and NN**

All units in XL and NN versions are supplied, as standard, with the latest 'Floating Frame' technology that completely isolates the compressors from the main casing, thereby eliminating vibration and noise from this source. The 'Floating Frame' is a special vibration and acoustic damping system that consists of a base plate and acoustic enclosure that houses the compressors. The base plate is separated from the supporting frame of the unit by soft steel springs that have a high damping power. Within the enclosure, the compressors are mounted on rubber shock absorbers on the floating base plate. The enclosure is manufactured from galvanized steel sandwich panels that have a micro-perforated inner skin and a core of 30 mm thick, high density (25 kg/m<sup>3</sup>). The entire arrangement provides a double damping system and acoustic attenuation. The compressor refrigerant pipes are connected to the refrigerant circuit through "anaconda" flexible connections. Flexible connections are also used on the water pipework within the unit. The combination of these systems results in an overall noise reduction in the region of 6-8 dB(A).

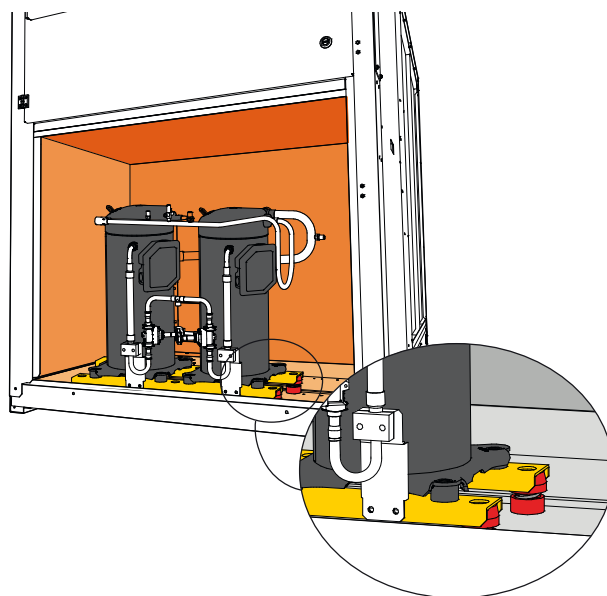

**P4S VERSION**

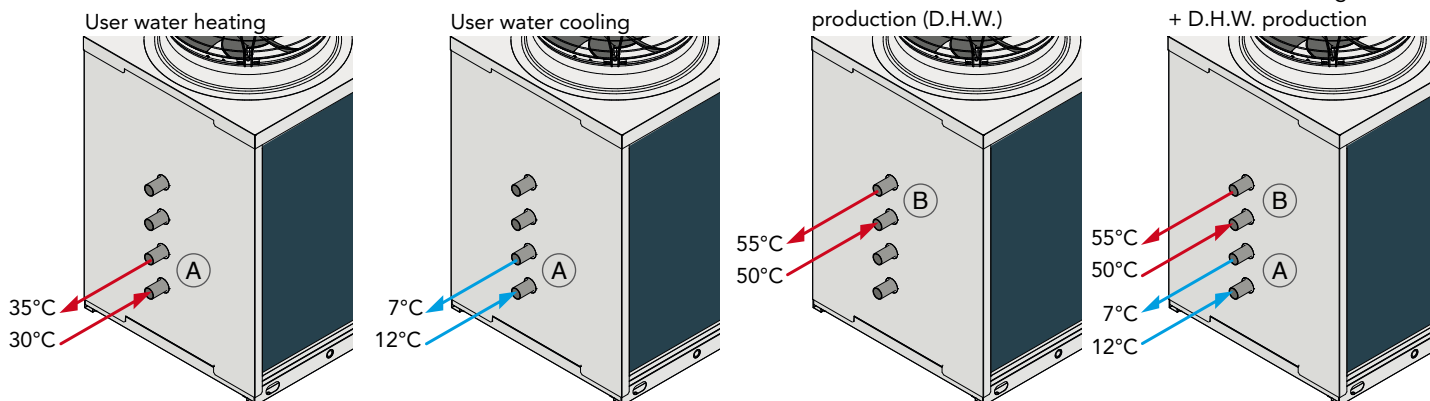

The above scheme is for illustrative purposes only. For the correct pipes placement, please refer to the units technical manual.

# ACCESSORIES

LZT/P4

LZT		242 252	292 302	312	432	452	492	502	592	602
Flow switch		●	●	●	●	●	●	●	●	●
"Floating frame" Technology - LS Version		-	-	-	-	-	-	-	-	-
"Floating frame" Technology - XL - NN Version		●	●	●	●	●	●	●	●	●
E.C. fans - SA/LS versions	VECE	-	-	-	-	-	-	-	-	-
E.C. fans - SE/LS versions	VECE	●	●	●	●	●	●	●	●	●
E.C. fans - HA/LS - HA/XL versions	VECE	-	-	-	-	-	-	-	-	-
E.C. fans - HE/LS - HE/XL - HE/NN versions	VECE	●	●	●	●	●	●	●	●	●
Condensate discharge drip tray with antifreeze heater	BRCA	○	○	○	○	○	○	○	○	○
Condensing pressure control by transducer & EC Fans (only for SE and HE)		●	●	●	●	●	●	●	●	●
Fans regulation by phase cut (only SA - HA)	DCCF	●	●	●	●	●	●	●	●	●
Antifreeze kit for 4 pipe units	RAEV4	○	○	○	○	○	○	○	○	○
Electronic soft starter	DSSE	○	○	○	○	○	○	○	○	○
Serial interface card RS485	INSE	●	●	●	●	●	●	●	●	●
Rubber anti-vibration mountings	KAVG	○	○	○	○	○	○	○	○	○
Remote control panel	PCRL	○	○	○	○	○	○	○	○	○
Electronic expansion valve	VTEE	○	○	○	○	○	○	○	○	○
Cascade control system via RS485	SGRS	○	○	○	○	○	○	○	○	○
Hydraulic kit with one pump with tank *	A1ZZU	○	○	○	○	○	○	○	○	○
Hydraulic kit with two pumps with tank *	A2ZZU	○	○	○	○	○	○	○	○	○
Hydraulic kit with one pump without tank *	A1NTU	○	○	○	○	○	○	○	○	○
Hydraulic kit with two pumps without tank *	A2NTU	○	○	○	○	○	○	○	○	○

\* Not available for NN versions

● Standard ○ Optional - Not available

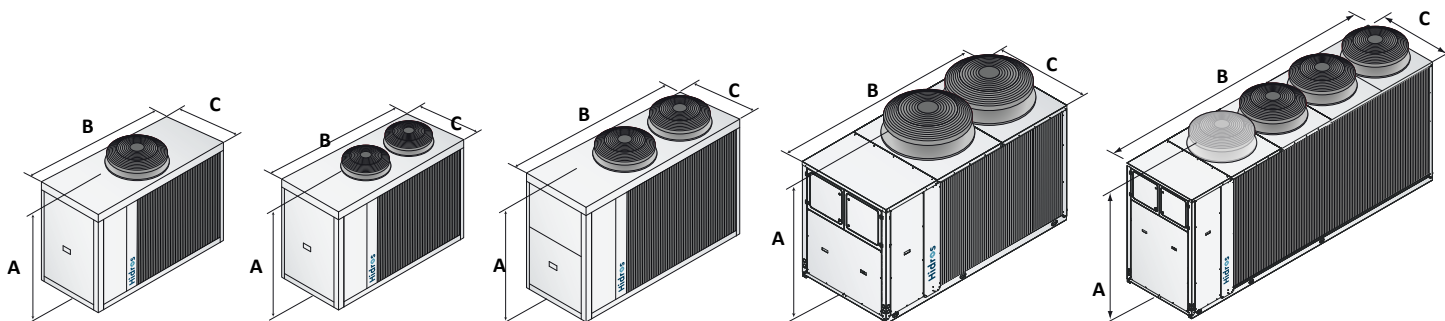

**SA/SE 242-292**  
**HA/HE/LS 242-292**

**HA-HE/XL 252 - 302**  
**HE/NN 252 - 312**

**SA/SE 432 - 492 - 592**  
**HA-HE/LS-XL 432 - 492**  
**HE/NN 312**

**SA/SE 752-852**  
**HA-HE/LS-XL 592 - 602 - 752 - 852**  
1002 - 1202  
**HE/NN 452 - 502 - 602 - 752 - 852**

**SA/SE 1002-1202**  
**HE/NN 1002-1202**

		242/252	292/302	312	432	452	492	502	592	602
A (mm)	<b>SA-SE/LS</b>	1500	1500	--	1690	--	1690	--	1690	--
B (mm)	<b>SA-SE/LS</b>	1915	1915	--	2400	--	2400	--	2400	--
C (mm)	<b>SA-SE/LS</b>	875	875	--	1150	--	1150	--	1150	--
kg	<b>SA-SE/LS</b>	1000	1000	--	1500	--	1500	--	1500	--
A (mm)	<b>HA-HE/LS</b>	1500	1500	--	1670	--	1690	--	--	1820
B (mm)	<b>HA-HE/LS</b>	1915	1915	--	2400	--	2400	--	--	2905
C (mm)	<b>HA-HE/LS</b>	875	875	--	1150	--	1150	--	--	1150
kg	<b>HA-HE/LS</b>	1000	1000	--	1500	--	1500	--	--	1060
A (mm)	<b>HA-HE/XL</b>	1500	1500	--	1670	--	1690	--	--	1820
B (mm)	<b>HA-HE/XL</b>	1915	1915	--	2400	--	2400	--	--	2905
C (mm)	<b>HA-HE/XL</b>	875	875	--	1150	--	1150	--	--	1150
kg	<b>HA-HE/XL</b>	1000	1000	--	1500	--	1500	--	--	1080
A (mm)	<b>HE/NN</b>	1500	--	1690	--	1820	--	1880	--	1880
B (mm)	<b>HE/NN</b>	1915	--	2400	--	2905	--	2905	--	2905
C (mm)	<b>HE/NN</b>	875	--	1150	--	1150	--	1150	--	1150
kg	<b>HE/NN</b>	1000	--	1500	--	1080	--	1100	--	1110



LZT		752	852	1002	1202	1454	1654	1854	2154
Flow switch		●	●	●	●	●	●	●	●
"Floating frame" Technology - LS Version		-	-	-	-	-	-	-	-
"Floating frame" Technology - XL - NN Version		●	●	●	●	●	●	●	●
E.C. fans - SA/LS versions	VECE	-	-	-	-	-	-	-	-
E.C. fans - SE/LS versions	VECE	●	●	●	●	●	●	●	●
E.C. fans - HA/LS - HA/XL versions	VECE	-	-	-	-	-	-	-	-
E.C. fans - HE/LS - HE/XL - HE/NN versions	VECE	●	●	●	●	●	●	●	●
Condensate discharge drip tray with antifreeze heater	BRCA	○	○	○	○	○	○	○	○
Condensing pressure control by transducer & EC Fans (only for SE and HE)		●	●	●	●	●	●	●	●
Fans regulation by phase cut (only SA - HA)	DCCF	●	●	●	●	●	●	●	●
Antifreeze kit for 4 pipe units	RAEV4	○	○	○	○	○	○	○	○
Electronic soft starter	DSSE	○	○	○	○	○	○	○	○
Serial interface card RS485	INSE	●	●	●	●	●	●	●	●
Rubber anti-vibration mountings	KAVG	○	○	○	○	○	○	○	○
Remote control panel	PCRL	○	○	○	○	○	○	○	○
Electronic expansion valve	VTEE	○	○	○	○	○	○	○	○
Cascade control system via RS485	SGRS	○	○	○	○	○	○	○	○
Hydraulic kit with one pump with tank *	A1ZZU	○	○	○	○	○	○	○	○
Hydraulic kit with two pumps with tank *	A2ZZU	○	○	○	○	○	○	○	○
Hydraulic kit with one pump without tank *	A1NTU	○	○	○	○	○	○	○	○
Hydraulic kit with two pumps without tank *	A2NTU	○	○	○	○	○	○	○	○

\* Not available for NN versions

● Standard ○ Optional - Not available

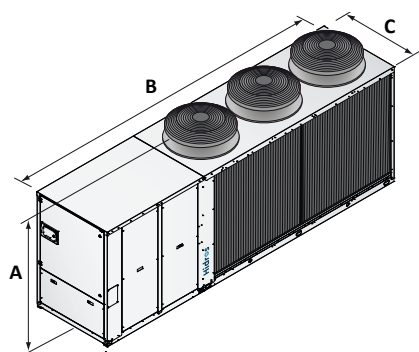

**HA-HE/LS** 1454 - 1654  
1854 - 2154

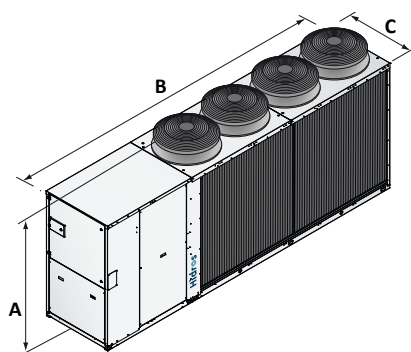

**SA-SE/LS** 1454 - 1654  
1854 - 2154

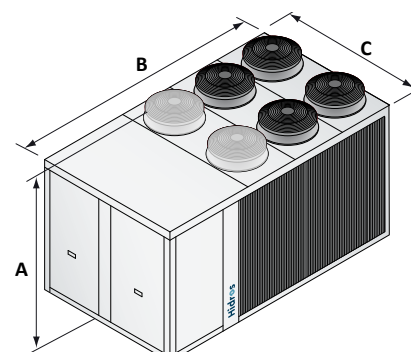

**HA-HE/XL** 1454 - 1654 - 1854 - 2154  
**HE/NN** 1454 - 1654 - 1854 - 2154

		752	852	1002	1202	1454	1654	1854	2154
A (mm)	<b>SA-SE/LS</b>	1880	1880	1890	1890	2310	2310	2310	2310
B (mm)	<b>SA-SE/LS</b>	2905	2905	3905	3905	5300	5300	5300	5300
C (mm)	<b>SA-SE/LS</b>	1150	1150	1150	1150	1150	1150	1150	1150
kg	<b>SA-SE/LS</b>	2000	2000	2000	2000	2500	2540	2580	2620
A (mm)	<b>HA-HE/LS</b>	1880	1880	1880	1880	1895	1895	1895	1895
B (mm)	<b>HA-HE/LS</b>	2905	2905	2905	2905	4695	4695	4695	4695
C (mm)	<b>HA-HE/LS</b>	1150	1150	1150	1150	1150	1150	1150	1150
kg	<b>HA-HE/LS</b>	2000	2000	2000	2000	2580	2640	2720	2760
A (mm)	<b>HA-HE/XL</b>	1880	1880	1880	1880	2350	2350	2350	2350
B (mm)	<b>HA-HE/XL</b>	2905	2905	2905	2905	4205	4205	4205	4205
C (mm)	<b>HA-HE/XL</b>	1150	1150	1150	1150	2210	2210	2210	2210
kg	<b>HA-HE/XL</b>	2000	2000	2000	2000	2500	2540	2580	2620
A (mm)	<b>HE/NN</b>	1880	1880	1890	1890	2350	2350	2350	2350
B (mm)	<b>HE/NN</b>	2905	2905	3905	3905	4205	4205	4205	4205
C (mm)	<b>HE/NN</b>	1150	1150	1150	1150	2210	2210	2210	2210
kg	<b>HE/NN</b>	2000	2000	2000	2000	2750	2800	2840	2890

# TFW-TFWS

## DOMESTIC HOT WATER CYLINDERS

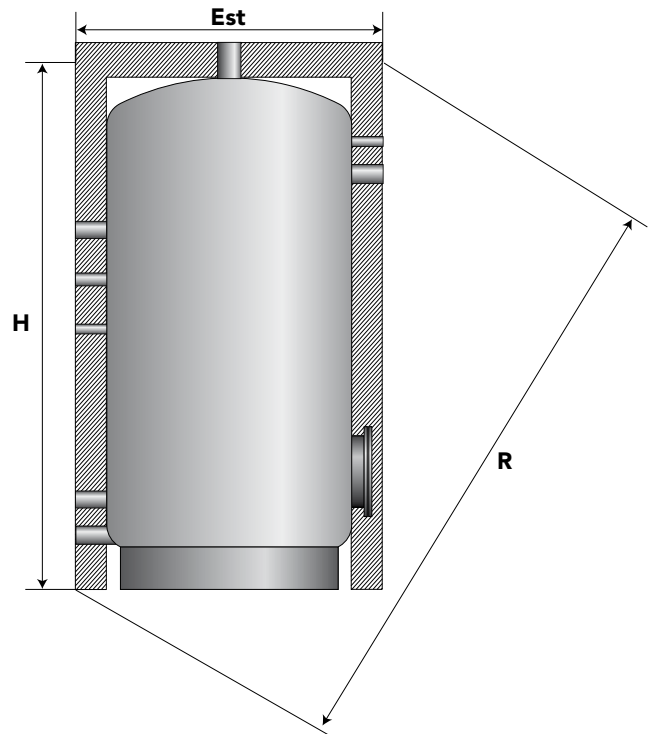

The TFW-TFWS series domestic hot water cylinders, are designed to heat and store domestic hot water, using an indirect coil. They are supplied with a double spiral heat exchanger, specifically designed for application with heat pumps. The units can also be used, in combination with gas or oil boilers. The outlet of the hot water is located in the upper part of the cylinder in order to get the highest possible water temperature. The units are manufactured from carbon steel S235 JR, enamelled at 850°C, according to DIN 4753. The TFW versions are supplied with a single heat exchanger, in carbon steel, enamelled, designed for heat pumps applications. The TFWS versions also incorporate a solar heat exchanger, located in the lower part of the tank to enhance the heating capacity. Both versions are supplied complete with magnesium anode, probe holders, inspection flange and backup electric heater flange.

### VERSIONS AND ACCESSORIES

- TFW** Domestic hot water cylinder.
- TFWS** Domestic hot water cylinder + solar coil.
- RE** Back up electric heater.

### PRODUCT SPECIFICATIONS

- Thermal insulation in rigid polyurethane + PVC
- Cathodic protection with magnesium anode.
- Thermometer located in sensor pocket.
- Inspection flange.
- Adjustable feet.
- Safety valve.

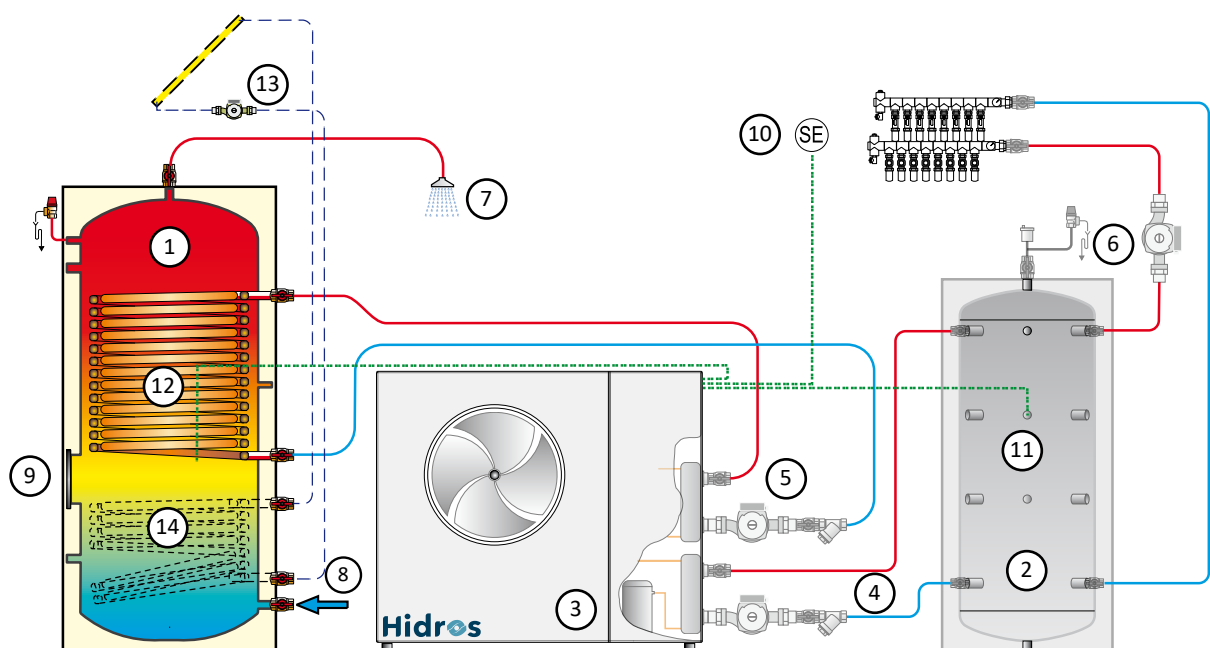

1	Domestic hot water cylinder TFW/TFWS	8	Cold water inlet
2	Buffer tank TFF	9	Back up heater flange
3	Heat pump	10	External sensor (Supplied with the heat pump)
4	Primary circuit pump (Heating and cooling)	11	Hot water sensor (Supplied with the heat pump)
5	Domestic hot water pump	12	D.H.W. sensor (Supplied with the heat pump)
6	Underfloor system water pump	13	Solar system
7	Domestic hot water outlet	14	Solar coil (TFWS versions only)

The above scheme is for illustrative purposes only

TFW - TFWS		300	500	750	1000	
Energy class		B	C	C	C	
Maximum working pressure	bar	10	10	10	10	
Heat pump D.H.W. heat exchanger surface (TFW/TFWS)	m <sup>2</sup>	3,8/2,2	6,0/4,8	6,5/--	6,5/--	
D.H.W. exchanger water content	lt	25,0/14,5	39,5/31,5	42,5/--	42,5/--	
D.H.W. exchanger waterflow	l/h	3000	3000	3000	3000	
D.H.W. exchanger pressure drops	Kpa	4,8	9,2	9,2	9,2	
Solar coil surface (TFWS versions only)	m <sup>2</sup>	1,0	1,8	--	--	
Solar coil water content (TFWS versions only)	lt.	6,5	11,5	--	--	
Solar coil waterflow (TFWS versions only)	l/h	1600	1900	--	--	
Solar coil pressure drops (TFWS versions only)	Kpa	4,0	9,0	--	--	
Diameter with insulation	EST	mm	670	700	855	1055
Total height	H	mm	1450	1870	2015	2050
Diagonal length	R	mm	1598	2019	2207	2306
Weight		kg	180	260	350	410

# TFP-TFPS

## HOT WATER STORAGE TANKS

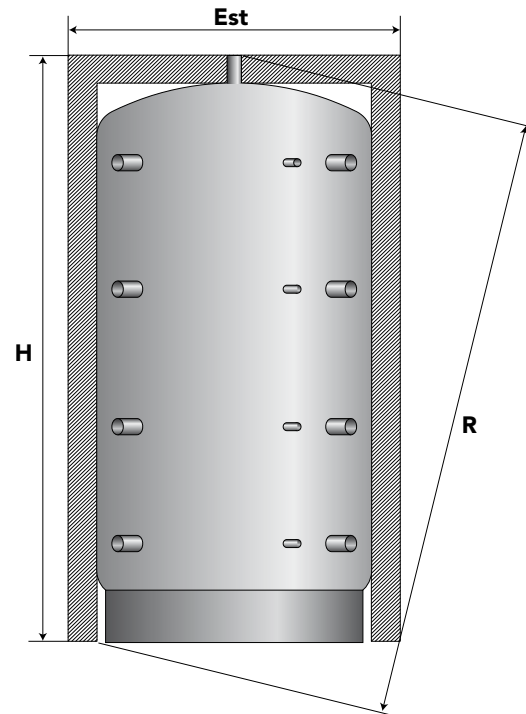

TFP-TFPS Hot water storage tanks are designed for use with heat stations and are connected directly to the heat pump.

They are thermally insulated with a flexible, polyurethane cover (CFC free and self extinguishing).

The tanks are supplied with 8 water connections and several probe pockets. The TFP versions are supplied without any heat exchanger, while the TFPS version incorporates a solar heat exchanger, located in the lower part of the tank to maximise the heating capacity.

TFP-TFPS storage tanks are suitable for hot water only, they are not to be used for cold water storage.

### VERSIONS AND ACCESSORIES

- TFP** Hot water storage tank.
- TFPS** Hot water storage tank + solar coil.
- RE** Back up electric heater.

### PRODUCT SPECIFICATIONS

- Thermal insulation protective jacket from size 300 to 1000.
- Thermal insulation in flexible polyurethane foam from size 1500.
- External protection with durable enamel coating.
- Manufactured from carbon steel ST235JR.

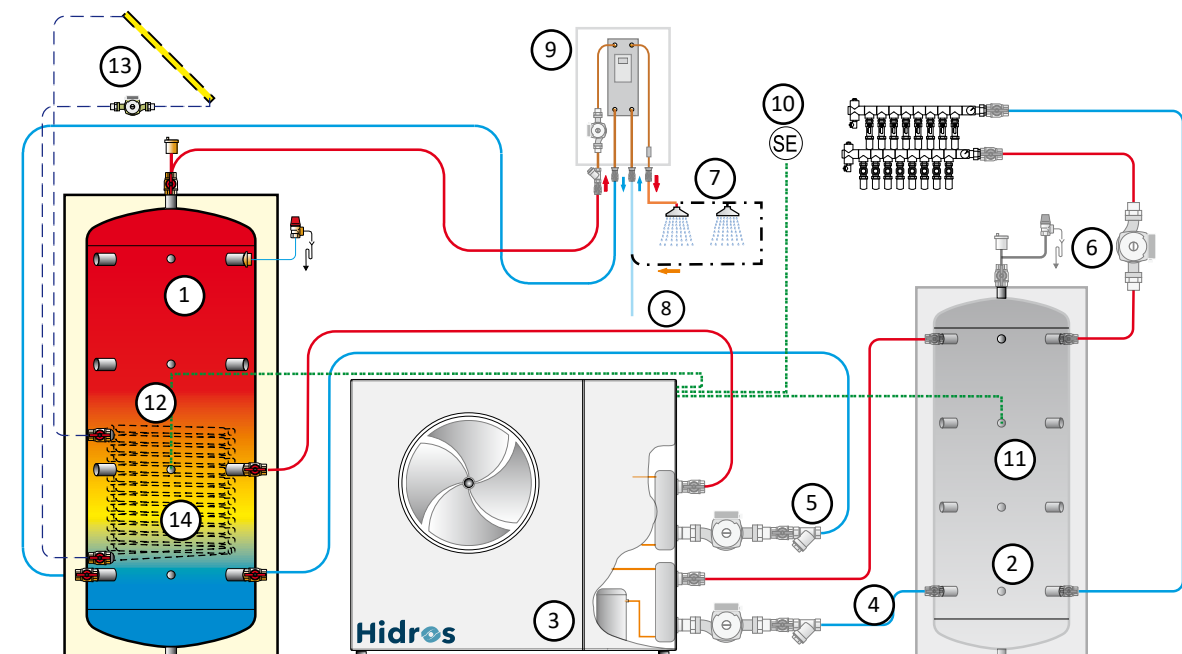

1	Hot water storage tanks TFP/TFPS	8	Cold water inlet
2	Buffer tank TFF	9	Domestic hot water station
3	Heat pump	10	External sensor (Supplied with the heat pump)
4	Primary circuit pump (Heating and cooling)	11	Hot water sensor (Supplied with the heat pump)
5	Domestic hot water pump	12	D.H.W. sensor (Supplied with the heat pump)
6	Underfloor system water pump	13	Solar system
7	Domestic hot water outlet	14	Solar coil (TFPS versions only)

The above scheme is for illustrative purposes only

TFP - TFPS		300	500	750	1000	1500	2000	2500	3000	4000	5000
Energy class		C	C	B	B	C	C	C	C	C	C
Maximum working pressure	bar	6	6	6	6	6	6	6	6	6	6
Maximum working temperature	°C	95	95	95	95	95	95	95	95	95	95
Solar heat exchanger surface (only TFPS)	m <sup>2</sup>	1,0	1,9	2,5	3,1	3,8	4,6	5,0	6,0	7,0	8,0
Diameter with insulation	EST mm	610	760	1010	1010	1240	1340	1450	1450	1600	1800
Total height	H mm	1680	1735	1840	2100	2140	2470	2220	2720	2810	2870
Diagonal dimension	R mm	1788	1895	2099	2331	2474	2811	2652	3083	3234	3388
Weight	kg	65	98	137	153	237	315	352	413	571	672

# TFF

## HOT AND COLD WATER STORAGE TANKS

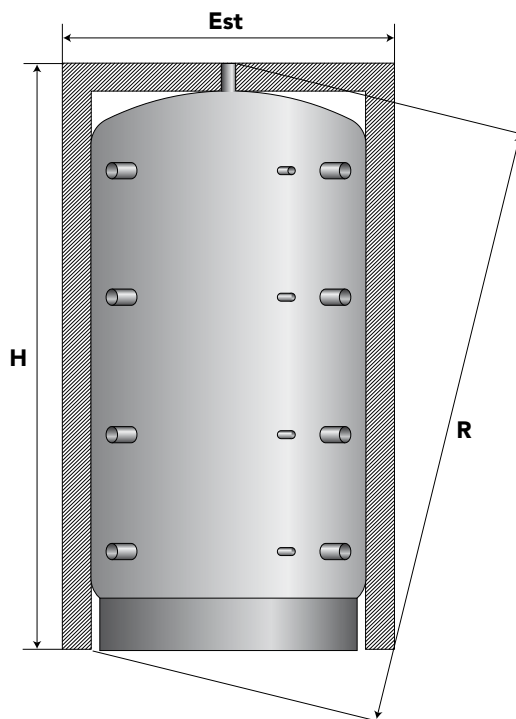

The TFF series of hot & cold water storage tanks are designed to provide buffer storage for the heating (cooling) system.

They are thermally insulated with a flexible, polyurethane cover (CFC free and self extinguishing).

The tanks are supplied with 8 water connections and several probe pockets. They are suitable for either hot or cold water.

### VERSIONS AND ACCESSORIES

**TFF** Hot and cold water storage tank.

**RE** Back up electric heater.

### PRODUCT SPECIFICATIONS

- Poliurethane rigid thermal insulation up to size 1000. Sizes from 1500 are supplied with an additional "anti-condensation elastomer".

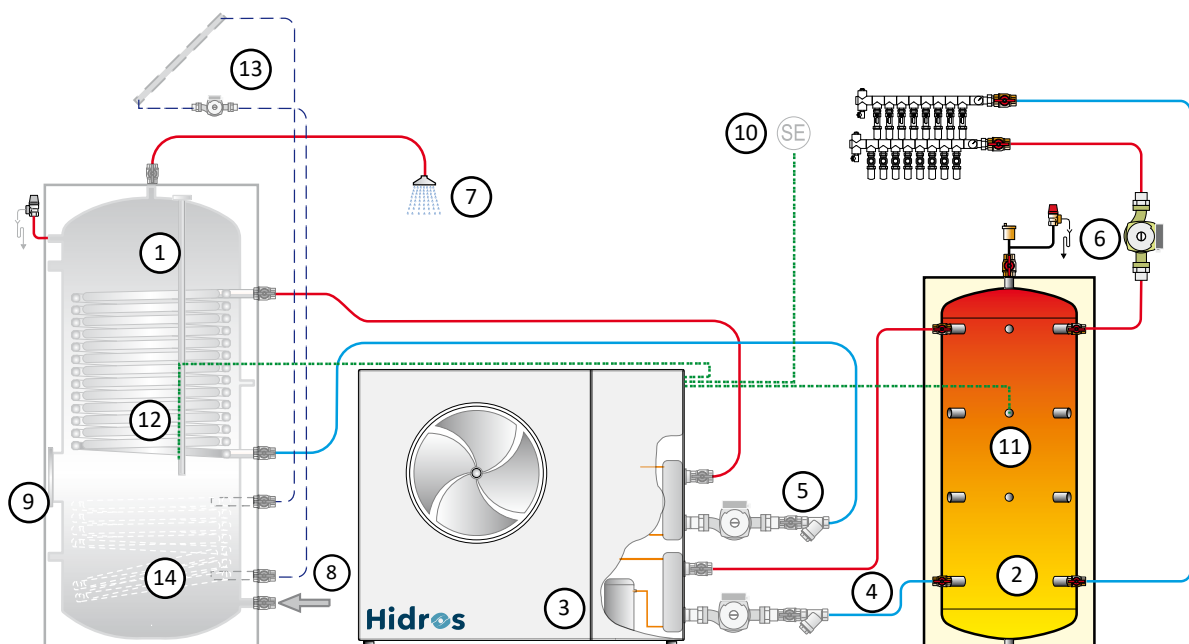

1	Hot and cold water tanks TFF	8	Cold water inlet
2	Buffer tank TFF	9	Back up heater flange
3	Heat pump	10	External sensor (Supplied with the heat pump)
4	Primary circuit pump (Heating and cooling)	11	Hot water sensor (Supplied with the heat pump)
5	Domestic hot water pump	12	D.H.W. sensor (Supplied with the heat pump)
6	Underfloor system water pump	13	Solar system
7	Domestic hot water outlet	14	Solar coil (TFWS versions only)

The above scheme is for illustrative purposes only

TFF		100	200	300	500	750	1000	1500	2000
Energy class		B	B	B	C	B	B	C	C
Maximum working pressure	bar	6	6	6	6	6	6	6	6
Maximum working temperature	°C	90	90	90	90	90	90	90	90
Diameter with insulation	EST mm	460	510	610	760	1010	1010	1240	1340
Total height	H mm	950	1341	1685	1721	1920	2175	2255	2575
Diagonal length	R mm	1056	1435	1793	1882	2170	2410	2574	2903
Weight	kg	25	36	48	80	106	130	218	260

# TFH-TFHS

## DOMESTIC HOT WATER GENERATORS

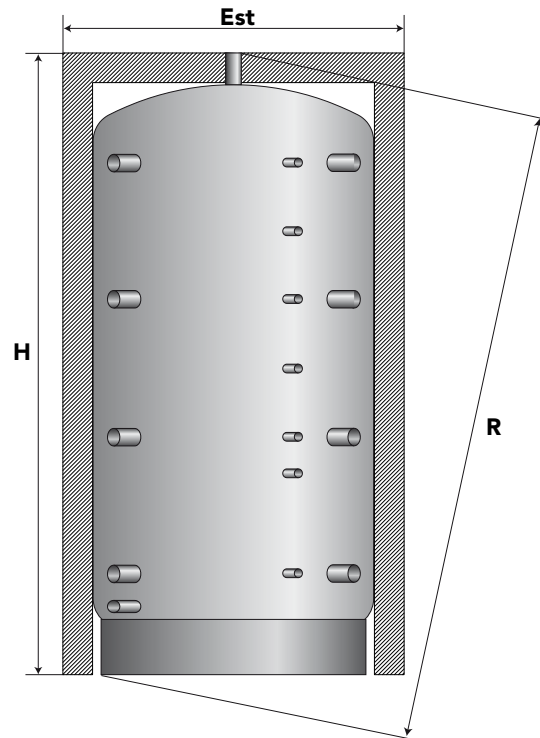

TFH-TFHS domestic hot water generators are designed to utilise the heat pump output with a high efficiency AISI 316L stainless steel pipe heat exchanger to instantaneously produce domestic hot water.

This arrangement eliminates the need for storage of hot water and the attendant legionella risk and treatments.

They are thermally insulated with a flexible, polyurethane cover (CFC free and self extinguishing).

They are supplied with 8 water connections and several probe pockets.

The TFHS versions incorporate an additional solar heat exchanger, located in the lower part to maximise the heating capacity.

### VERSIONS AND ACCESSORIES

- TFH** Domestic hot water generators.
- TFHS** Hot water storage tank + solar coil.
- RE** Back up electric heaters.

### PRODUCT SPECIFICATIONS

- Thermal insulation protective jacket.
- External protection with durable enamel coating.
- Internal construction made by carbon steel ST235JR.
- Domestic hot water heat exchanger, made in AISI316L corrugated stainless steel pipe, protected by pickling and passivation treatment.
- Thermometer with well for probe holder.



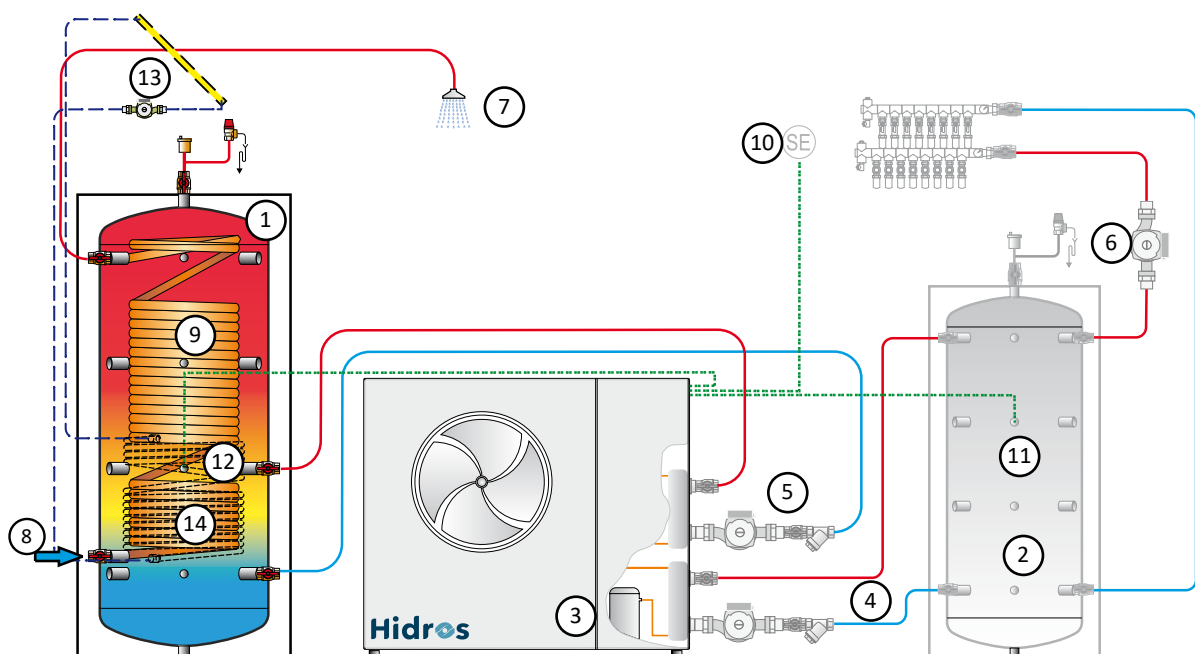

1	Domestic hot water generator TFH	8	Cold water inlet
2	Buffer tank TFF	9	D.H.W. stainless steel heat exchanger
3	Heat pump	10	External sensor (Supplied with the heat pump)
4	Primary circuit pump (Heating and cooling)	11	Hot water sensor (Supplied with the heat pump)
5	Domestic hot water pump	12	D.H.W. sensor (Supplied with the heat pump)
6	Underfloor system water pump	13	Solar system
7	Domestic hot water outlet	14	Solar coil (TFHS versions only)

The above scheme is for illustrative purposes only

TFH - TFHS		600	800	1000	1500	2000
Energy class		C	C	C	C	C
Maximum working pressure	bar	3	3	3	3	3
Maximum working temperature	°C	90	90	90	90	90
Heat exchanger surface	m <sup>2</sup>	5,6	5,6	7,0	7,0	8,0
Solar heat exchanger surface (only TFHS)	m <sup>2</sup>	1,4	1,8	1,8	3,0	4,5
Diameter with insulation	EST mm	860	950	950	1100	1300
Total height	H mm	1930	1900	2305	2665	2475
Diagonal length	R mm	2113	2125	2494	2884	2796
Weight	kg	205	232	246	371	404

# TFA-TFAS

## DOMESTIC HOT WATER STORAGE TANKS

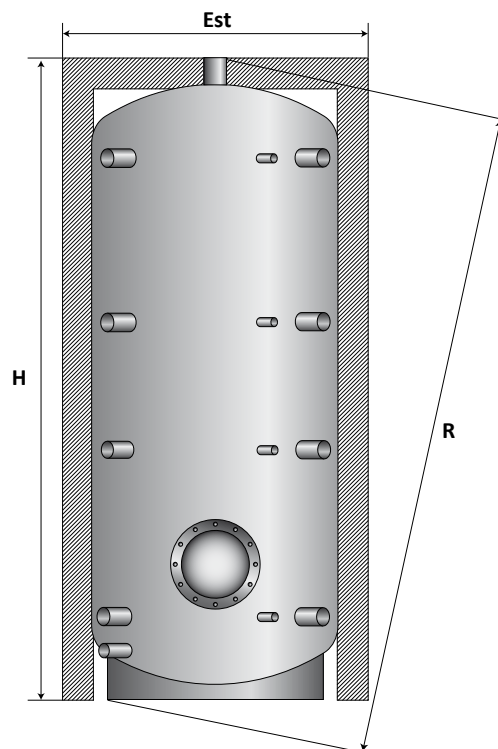

TFA - TFAS tanks are designed to be operated in conjunction with a plate heat exchanger to generate domestic hot water requirements.

This approach results in a faster response time than a traditional cylinder with an indirect coil.

They are manufactured from carbon steel S235JR enamelled in accordance with DIN 4753.

They are supplied complete with magnesium anode, probe holders, and inspection flange.

TFA tanks are supplied complete with 6 water connections placed in different positions of the tank and several sensor pockets.

The TFAS versions incorporate an additional solar heat exchanger, located in the lower part to maximise the heating capacity.

### VERSIONS AND ACCESSORIES

- TFA** Domestic hot water storage tank
- TFAS** Hot water storage tank + solar coil.
- RE** Back up electric heater.

### PRODUCT SPECIFICATIONS

- Polyurethane rigid thermal insulation up to size 1000.
- Thermal insulation in polyurethane foam from size 1500.
- External protection by high resistance enamel painting.
- Treatment with internal protective glazing inorganic food up to standard DIN 4753.3.
- Cathodic protection with magnesium anode.
- Thermometer with well for probe holder.
- Inspection flange.

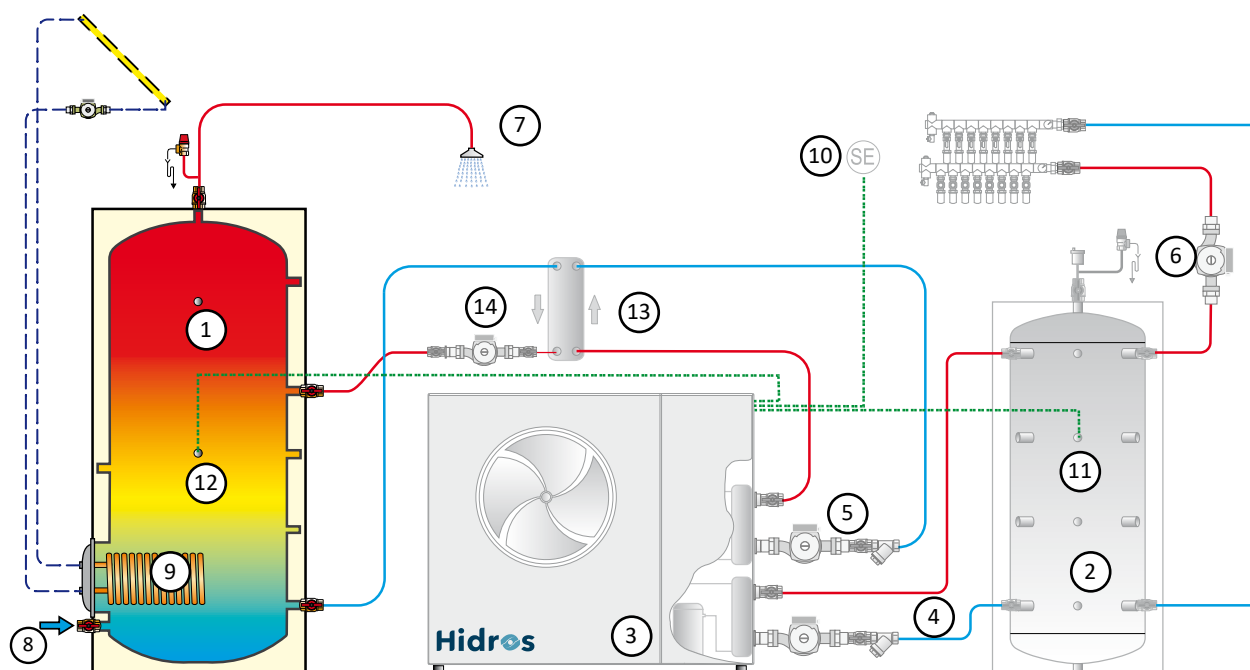

1	Domestic hot water storage tank	8	Cold water inlet
2	Buffer tank	9	Domestic hot stainless steel heat exchanger
3	Heat pump	10	External sensor (Supplied with the heat pump)
4	Primary circuit pump (Heating and cooling)	11	Hot water sensor (Supplied with the heat pump)
5	Primary circuit pump (D.H.W. circuit)	12	D.H.W. sensor (Supplied with the heat pump)
6	Underfloor system water pump	13	Plate heat exchanger
7	Domestic hot water outlet	14	D.H.W. circuit water pump

The above scheme is for illustrative purposes only

TFA - TFAS		200	300	500	750	1000	1500	2000	
Energy class		B	B	C	C	C	C	C	
Maximum working pressure	bar	10	10	10	10	10	6	6	
Maximum working temperature	°C	95	95	95	95	95	80	80	
Solar heat exchanger surface (only TFAS) *	m <sup>2</sup>	1,0	1,0	1,0	3,0	3,0	3,0	6,0	
Diameter with insulation	EST	mm	700	700	760	950	950	1240	1340
Total height	H	mm	1100	1340	1920	1970	2280	2275	2595
Diagonal length	R	mm	1304	1512	2065	2188	2470	2591	2921
Weight		kg	80	90	124	250	286	316	370

\* For any request of increased heat exchanger please contact the Company

## DOMESTIC HOT WATER HEAT STATIONS



The PI series of domestic hot water heat stations are complete plug and play systems, suitable for the production of the domestic hot water in combination with TFP-TFPS tanks.

A stainless steel plate heat exchangers to AISI 316, they incorporate high efficiency variable speed water pump and an electronic controller with display and electronic D.H.W. flow switch. The electronic control maintains a constant value of the outlet water temperature by modulating the waterflow of the primary circuit.

These devices enable the production of domestic hot water with minimal FORMATION OF LIMESTONE due to the very small amount of water present in the secondary water circuit.

## VERSIONS AND ACCESSORIES

**PI** Domestic hot water heat station.

## PRODUCT SPECIFICATIONS

- Precise regulation of water outlet temperature.
- Electronic driven water pump with very low input power.
- Graphic display with indication of water temperatures and heating capacity.
- Regulation of primary circuit water pump rpm depending on the required set point. Range: 30 - 65°C.
- Maximum water temperature Tmax. Range 60 -75°C.
- Management of recirculation water pump (max. input power 185W).Ability to control the secondary circuit water pump to maintain a constant temperature in the circuit (adjustable 10 - 40 °C).

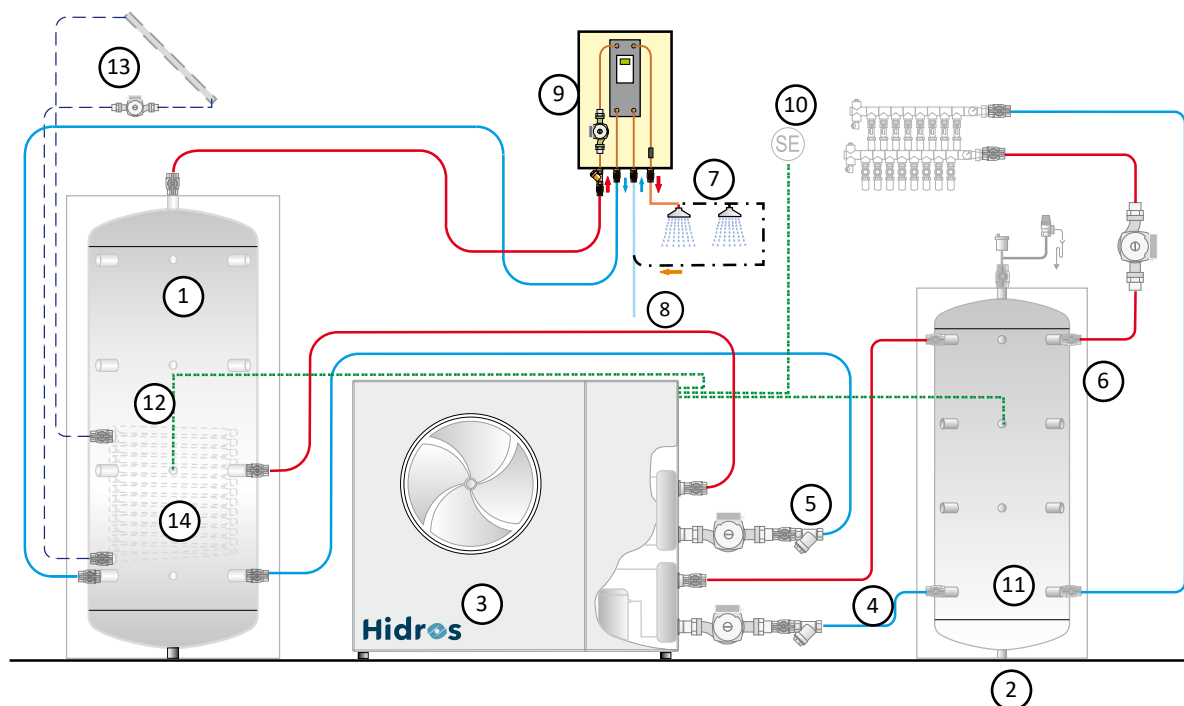

1	Hot water storage tanks TFP/TFPS	8	Cold water inlet
2	Buffer tank TFF	9	Domestic hot water station
3	Heat pump	10	External sensor (Supplied with the heat pump)
4	Primary circuit pump (Heating and cooling)	11	Hot water sensor (Supplied with the heat pump)
5	Domestic hot water pump	12	D.H.W. sensor (Supplied with the heat pump)
6	Underfloor system water pump	13	Solar system
7	Domestic hot water outlet	14	Solar coil (TFPS versions only)

The above scheme is for illustrative purposes only

PI		20	25	38	60	70	80	100	120
Power supply	V/PH/Hz	230/1/50	230/1/50	230/1/50	230/1/50	230/1/50	230/1/50	230/1/50	230/1/50
Water pump input power	W	40	52	80	310	310	310	450	450
Nominal domestic hot water circuit waterflow	l/min	20	25	38	60	70	80	100	120
Minimum domestic hot water flow	l/min	2	2	2	5	5	10	10	10
Water pump input current	A	0,66	0,66	0,66	1,37	1,37	1,37	2,01	2,01
Recirculation pump max. input power (optional)	W	185	185	185	185	185	185	185	185
Primary circuit waterflow	l/h	1500	1600	2500	6700	8200	9000	11000	14000
Primary circuit available static pressure	KPa	50	40	30	20	40	20	20	40
Weight	kg	18	19	20	166	168	189	193	198
Height	mm	590	590	590	871	871	871	871	871
Length	mm	374	374	374	1004	1004	1004	1004	1004
Width	mm	194	194	194	484	484	484	484	484
Primary water circuit volume	l	0,6	0,8	1,2	2,7	2,9	3,1	3,9	4,8
Domestic hot water circuit volume	l	0,7	0,9	1,4	2,5	2,1	3,1	3,8	4,7
Max. working pressure	bar	5	5	5	10	10	10	10	10
Protection degree	IP	40	40	40	40	40	40	40	40
Max. working temperature	°C	95	95	95	95	95	95	95	95



(A)

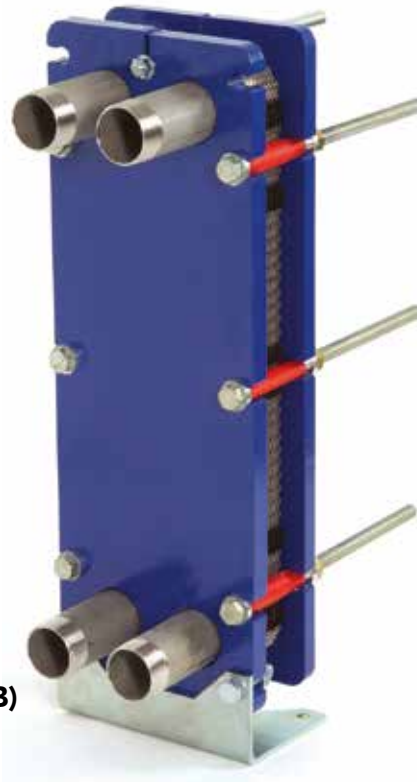

(B)

The SCP plate exchangers are designed for the production of the domestic hot water in combination with heat pump systems. The heat exchanger up to 20 Kw of heating capacity are brazed type, not inspectionable (picture A) while the bigger sizes are inspectionable and fixed with bolts and gaskets.

The use of plate heat exchanger allow the production of domestic hot water in an extreme efficient way, increasing the seasonal C.O.P. of the heat pump compared to other traditional systems.

### PRODUCT SPECIFICATIONS

- Heating capacities from 10 to 160 Kw, available on request for higher capacities.
- Working pressure up to 30 bar, up to 16 bar for bolts and gaskets versions.
- Produced in stainless steel AISI316.
- Treaded water connections.
- Primary circuit water flows from 1500 l/h to 2800 l/h.

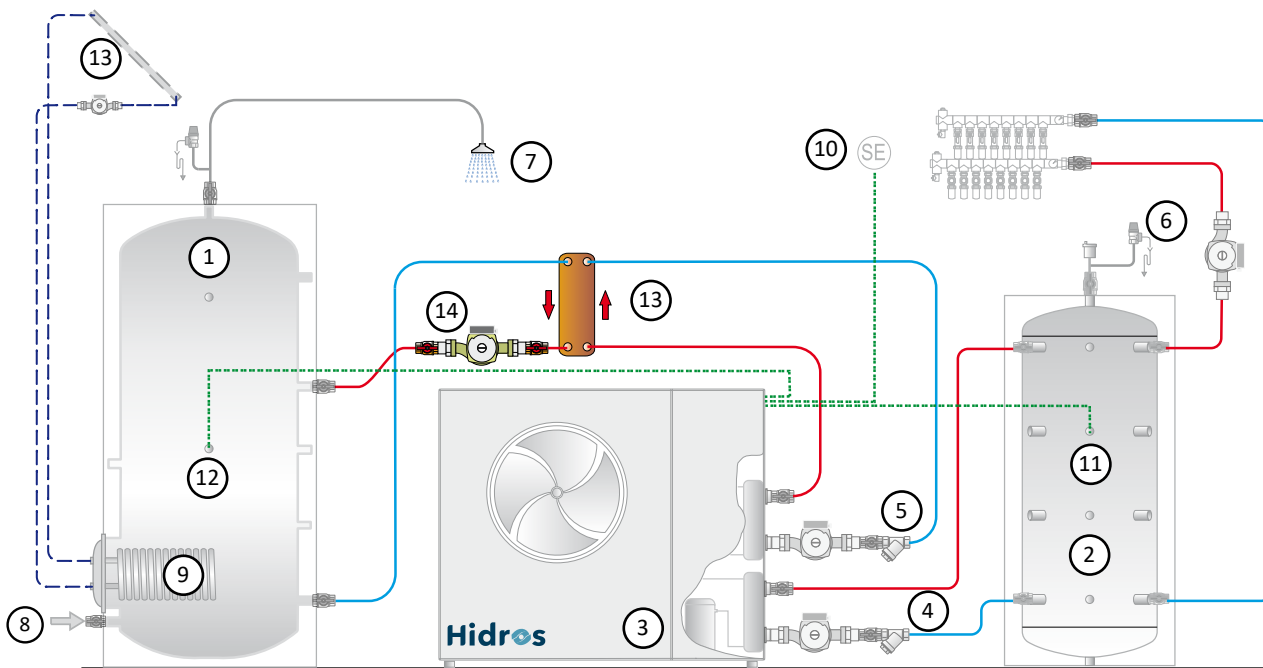

1	Domestic hot water storage tanks	8	Cold water inlet
2	Buffer tank	9	Domestic hot stainless steel heat exchanger
3	Heat pump	10	External sensor (Supplied with the heat pump)
4	Primary circuit pump (Heating and cooling)	11	Hot water sensor (Supplied with the heat pump)
5	Domestic hot water pump	12	D.H.W. sensor (Supplied with the heat pump)
6	Underfloor system water pump	13	Plate heat exchanger
7	Domestic hot water outlet	14	D.H.W. circuit water pump

The above scheme is for illustrative purposes only

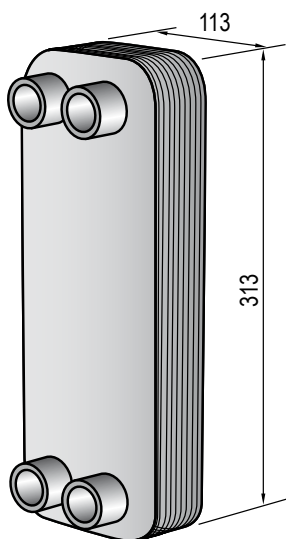

(A) 10 to 20 kW models

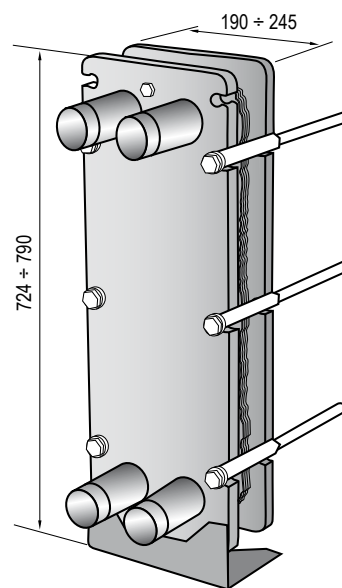

(B) 25 to 160 kW models



A programmable system comprising a central control that is connected, using two wire cables, to various control modules. In addition, the system communicates with all hidros heat pumps and will manage the heating, cooling and domestic hot water production.

The basic system can control 6 independent zones taking information from temperature and humidity sensors and activating valves, pumps and supplementary heaters.

XWEB supervision software can be added enabling remote monitoring and control via internet or GSM modem.

Mod-BUS protocol also enables integration of the system with other home automation products.

### VERSIONS AND ACCESSORIES

- 3 Mixing valves and 3 water pumps;
- 6 Zones with independent humidity and temperature control and dew point checking;
- Expansion module with an additional 6 zones.

### PRODUCT SPECIFICATIONS

- Dehumidification mode possible for 3 independent zones.
- Normal operation + set back temperature.
- Summer/winter change over.
- Control of supplementary heat.
- Cooling mode possible for 3 independent zones.
- Heat pump Alarm display.
- Serial interface port RS 485 (master and slave).
- Communication protocol Mod BUS-RTU.
- Connection to XWEB supervision systems or other open source applications.



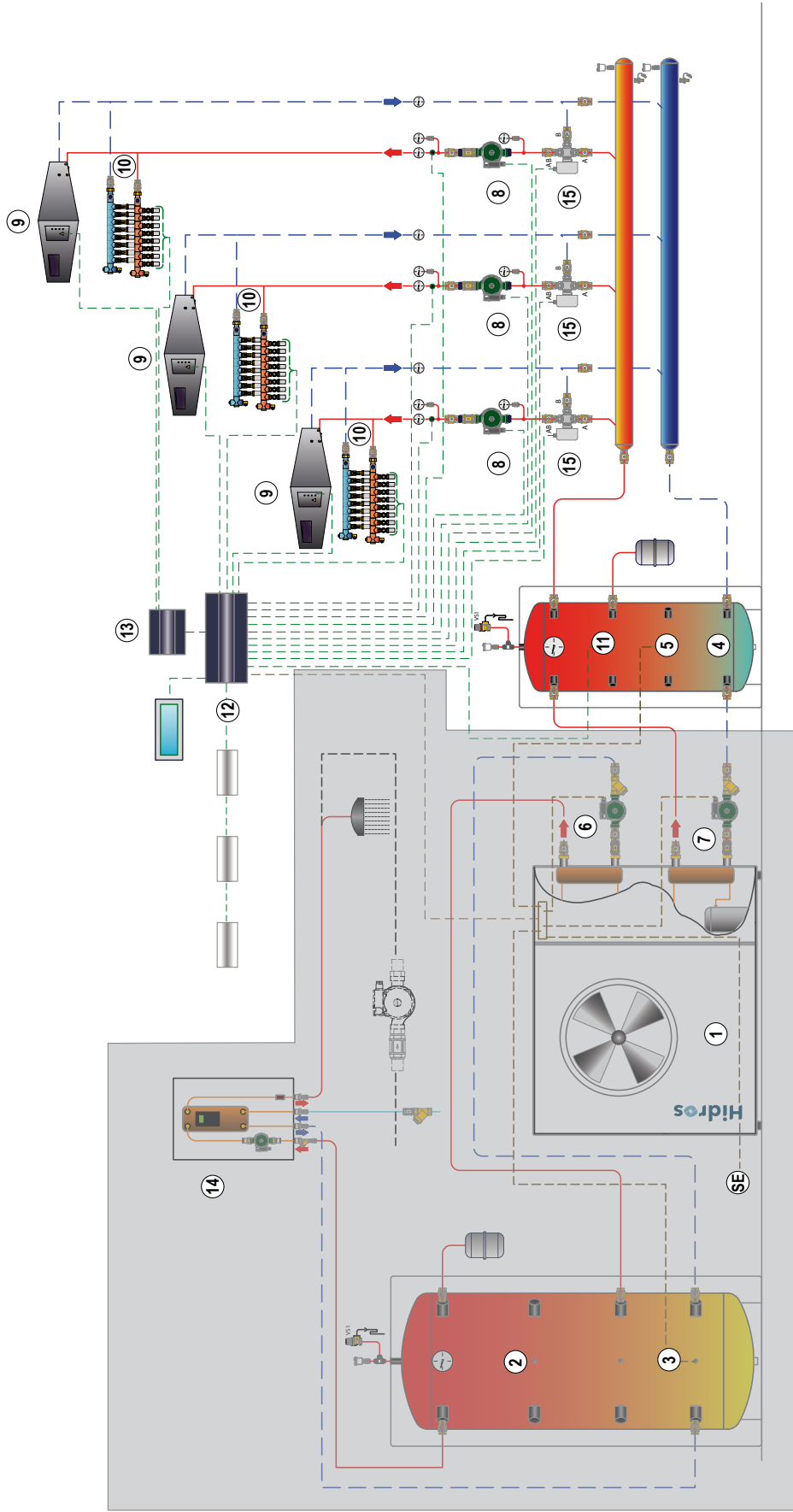

Installation of a control system for an air to water heat pump, with DHW circuit priority, equipped with weather -compensated ambient sensor. The management of the system is done by temperature/humidity sensors, connected via BUS line, programmable PLC controller and graphic display for the visualization of all the parameters. The software allows the control of the temperature and the humidity up to 32 zones, 3 dehumidifiers, 3 water pumps, boiler, water chiller and heat pump.

The above scheme is for illustrative purposes only

<b>1</b>	Heat Pump	<b>4</b>	Buffer Tank	<b>7</b>	Heating System Pump	<b>10</b>	Zone Manifold	<b>13</b>	Expansion Module
<b>2</b>	Hot Water Tank	<b>5</b>	Buffer Tank Sensor	<b>8</b>	Circulating Pump	<b>11</b>	System min Temp Sensor	<b>14</b>	Hot water Heat Station
<b>3</b>	Hot Water Sensor	<b>6</b>	Hot Water Pump	<b>9</b>	Dehumidifier	<b>12</b>	Central Controller	<b>15</b>	Mixing Valve



#### **RGAA.01 Programmable controller**

Plant programmable logic controller, able to manage: 6 independent zones in heating and cooling mode, 3 modulating valves and related water pumps, winter weather compensation set point, summer dew point control, 2 independent dehumidifiers with cooling integration, time zones set with 2 temperature levels, summer and winter working mode, heat pump remote start and stop, display of heat pump general alarm. The device is supplied with 2xRS485 serial output connection, (master and slave), standard communication protocol Mod BUS-RTU that allows the connection to the XWEB monitoring systems or existing applications. Power supply 24 Volt.



#### **RBB.01 Graphic display**

Graphic keypad, with LCD display, 240x96 pixel, 8 buttons with easy-to-use interface, suitable for wall mounting installation, supplied with buzzer. The built-in keyboard allows the user to display and set the temperature and humidity parameters in the different zones, summer and winter heat pump working mode, display the heat pump general alarm and set the time zones.



#### **RBB.02 Graphic display touch screen (HMI)**

Display TFT LCD 800x420 pixel, 262k colors with easy-to-use interface, suitable for wall mounting installation. The built-in keyboard allows the user to display and set the temperature and humidity parameters in the different zones, summer and winter heat pump working mode, display the heat pump general alarm and set the time zones.

- Microprocessor ARM9;
- Mass storage media: SD card.



#### **RGDD.01 Temperature and humidity sensor**

- Wall mounting electronic temperature+humidity sensor;
- ABS plastic box;
- Working range 0-95% R.H. +/- 0-50°C;
- 0-10V signal;
- Accuracy +/- 2% R.H.; +/- 0,25°C;
- Power supply 24 VAC.



#### **MICR.0540 Web server supervisor module**

- WEB SERVER for supervision of the parameters;
- Power supply: 230 V AC +/- 10%;
- Internal memory 48 MB;
- Communication protocol modBUS-RTU;
- Output: LAN: x1 - USB: x 2;
- Alarm relays: RS485 x 2, system x 1;
- Ports: RS232 for external modem - RS485 digital input;
- Internal modem: Optional (analogue or GSM);
- Sampling interval: 1 to 60 min;
- Alarm signalling: via fax, mail, SMS or relay output.

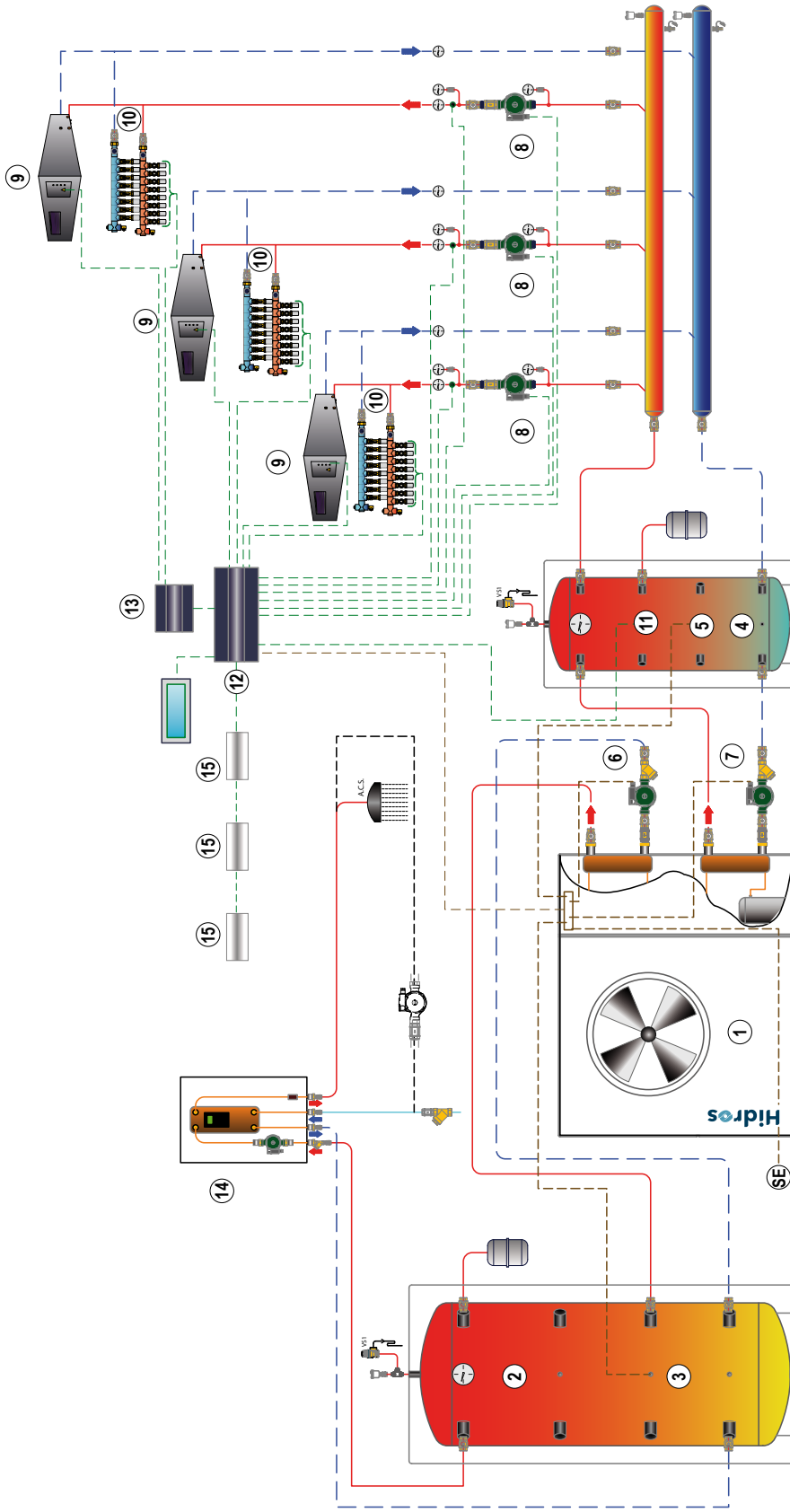

Installation of an air to water heat pump system, 4 pipes version, with DHW circuit priority, equipped with weather -compensated ambient sensor.

The Domestic hot water is produced using a hot water storage tank and a hot water station (with re-circulation).

The heating and cooling circuit comprises a hot and cold water storage tank, underfloor heating/cooling system and dehumidification controlled by Dehumidifiers for radiant cooling systems with heat recovery with cooling integration.

Supervision of the system is by temperature/humidity sensors, connected in BUS line, programmable PLC with Modbus protocol and graphic display for the visualization of the different parameters.

The above scheme is for illustrative purposes only

1	Heat Pump	4	Buffer Tank	7	Heating System Pump	10	Zone Manifold	13	Expansion Module
2	Hot Water Tank	5	Buffer Tank Sensor	8	Circulating Pump	11	System min Temp Sensor	14	Hot water Heat Station
3	Hot Water Sensor	6	Hot Water Pump	9	Dehumidifier	12	Central Controller	15	Mixing Valve

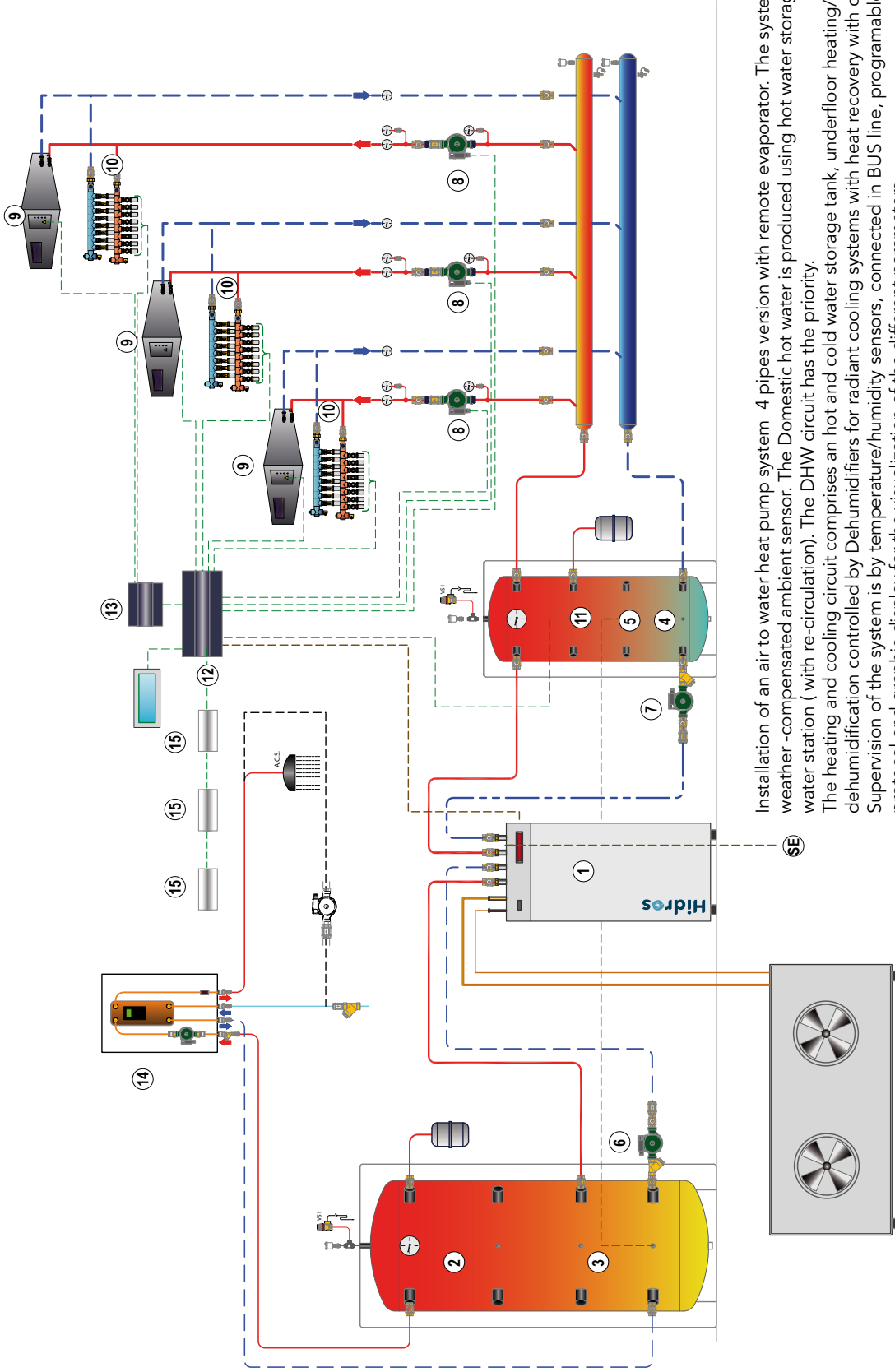

Installation of an air to water heat pump system 4 pipes version with remote evaporator. The system is equipped with weather -compensated ambient sensor. The Domestic hot water is produced using hot water storage tank and a PI hot water station ( with re-circulation). The DHW circuit has the priority. The heating and cooling circuit comprises an hot and cold water storage tank, underfloor heating/cooling system and dehumidification controlled by Dehumidifiers for radiant cooling systems with heat recovery with cooling integration. Supervision of the system is by temperature/humidity sensors, connected in BUS line, programmable PLC with Modbus protocol and graphic display for the visualization of the different parameters.

The above scheme is for illustrative purposes only

<b>1</b>	Heat Pump	<b>4</b>	Buffer Tank	<b>7</b>	Heating Pump	<b>10</b>	Zone Manifold	<b>13</b>	Expansion Module
<b>2</b>	Hot Water Tank	<b>5</b>	Heating Sensor	<b>8</b>	Zone Pump	<b>11</b>	Min Temperature Sensor	<b>14</b>	Heat Station
<b>3</b>	Hot Water Sensor	<b>6</b>	Hot Water Pump	<b>9</b>	Dehumidifier	<b>12</b>	Controller	<b>15</b>	Temperature Sensor

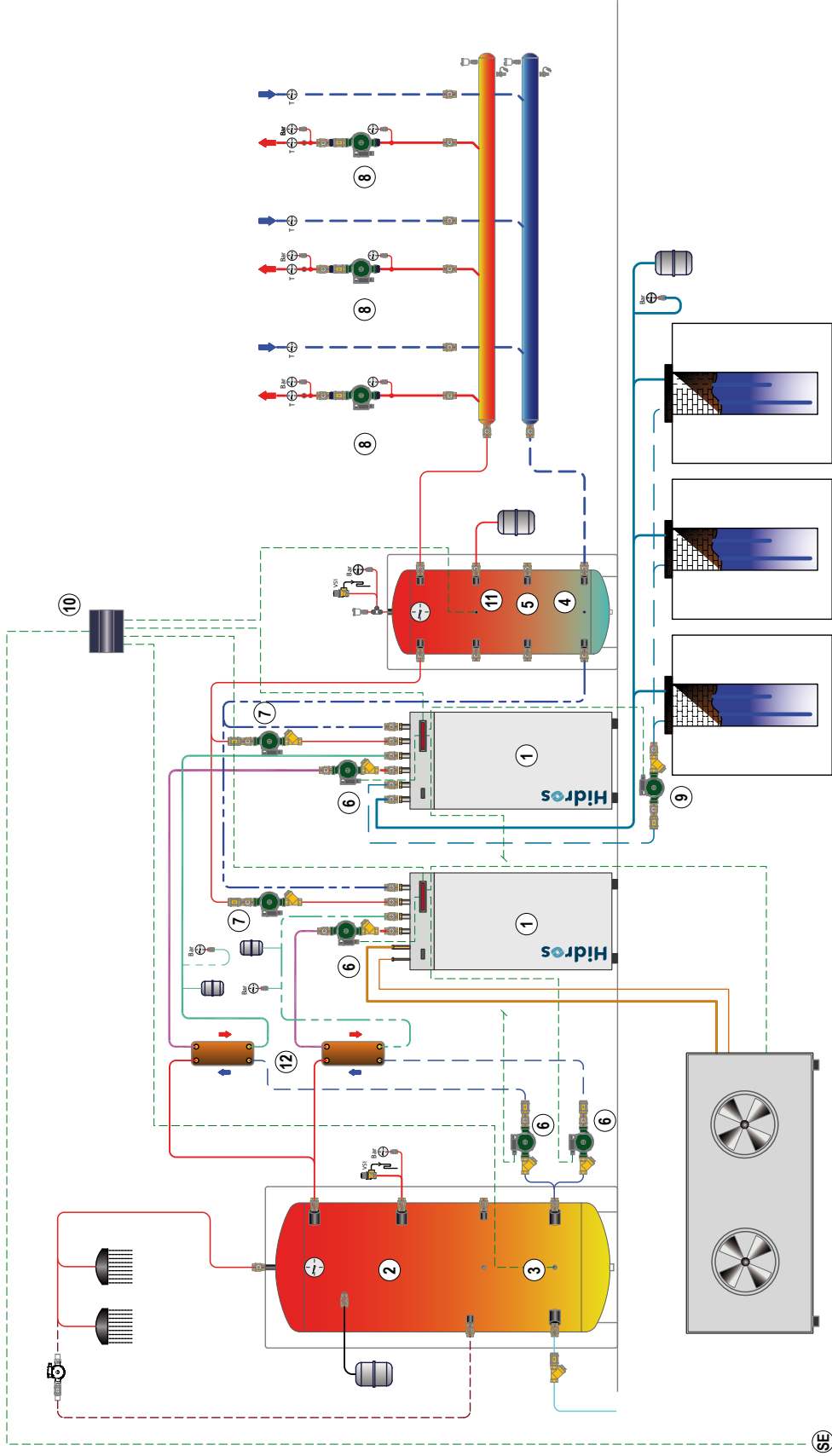

Installation of a heat pump system that is composed of a split type air to water heat pump WZT 4 pipes and a ground source heat pump 4 pipes. They are managed in cascade. The system is equipped with a weather-compensated ambient sensor able to manage both units. The Domestic hot water is produced using a domestic hot water storage tank and plate heat exchangers. The heating and cooling circuit comprises a hot and cold water storage tank and underfloor heating/cooling system. The supervision of the system is made by a cascade controller with Modbus protocol.

The above scheme is for illustrative purposes only

<b>1</b>	Heat Pump	<b>4</b>	Buffer Tank	<b>7</b>	Heating Pump	<b>10</b>	Cascade Controller
<b>2</b>	Hot Water Tank	<b>5</b>	Heating Sensor	<b>8</b>	Zone Pump	<b>11</b>	Min Temperature Sensor
<b>3</b>	Hot Water Sensor	<b>6</b>	Hot Water Pump	<b>9</b>	Source Exchanger Pump	<b>12</b>	Plate heat Exchanger

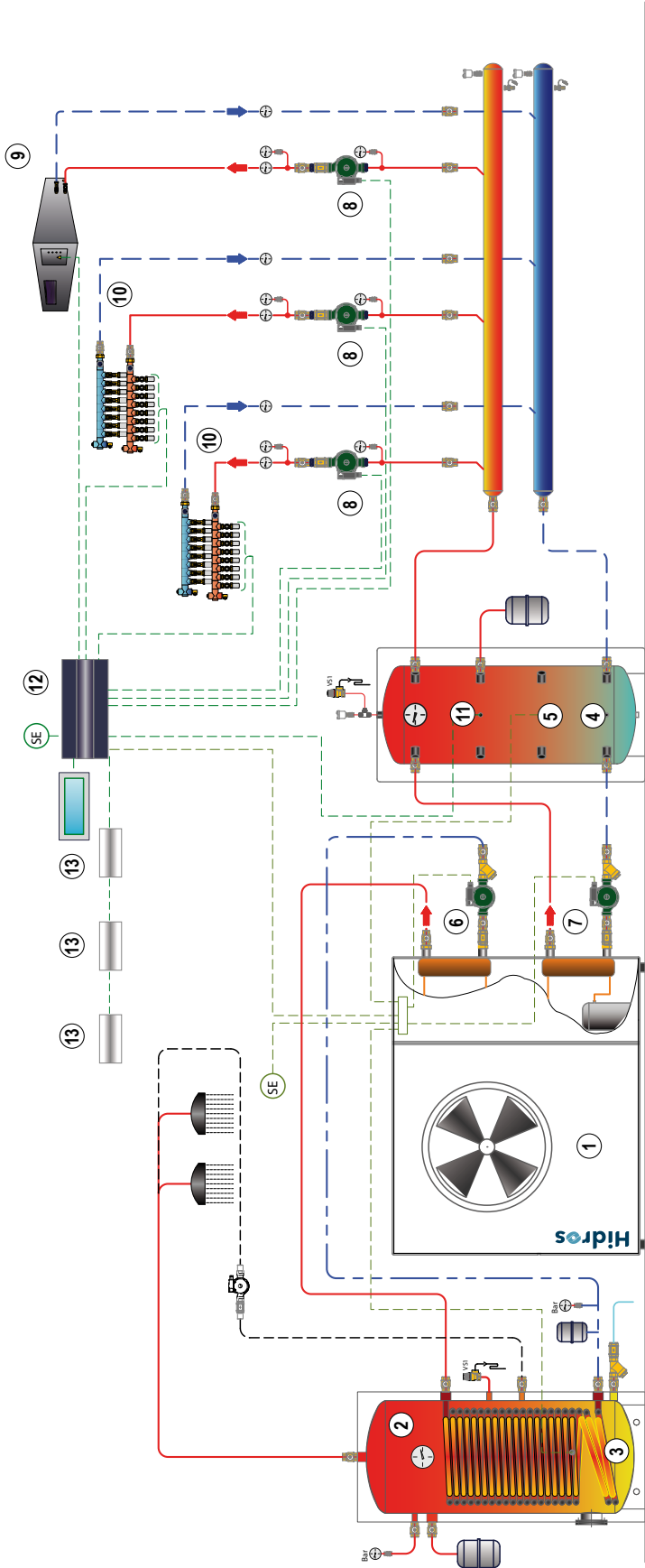

Installation of an air to water heat pump system 4 pipes version. The system is equipped with weather -compensated ambient sensor.

The Domestic hot water is produced using a domestic hot water cylinder. The DHW circuit has the priority.

The heating and cooling circuit comprises hot and cold water storage tank, underfloor heating/cooling system and dehumidification controlled by Dehumidifiers for radiant cooling systems with heat recovery with cooling integration.

Supervision of the system is by temperature/humidity sensors, connected in BUS line, programmable PLC with Modbus protocol and graphic display for the visualization of the different parameters.

The above scheme is for illustrative purposes only

<b>1</b>	Heat Pump	<b>4</b>	Buffer Tank	<b>7</b>	Heating Pump	<b>10</b>	Zone Manifold	<b>13</b>	Temperature Sensor
<b>2</b>	Hot Water Tank	<b>5</b>	Heating Sensor	<b>8</b>	Zone Pump	<b>11</b>	Min Temperature Sensor		
<b>3</b>	Hot Water Sensor	<b>6</b>	Hot Water Pump	<b>9</b>	Dehumidifier	<b>12</b>	Controller		

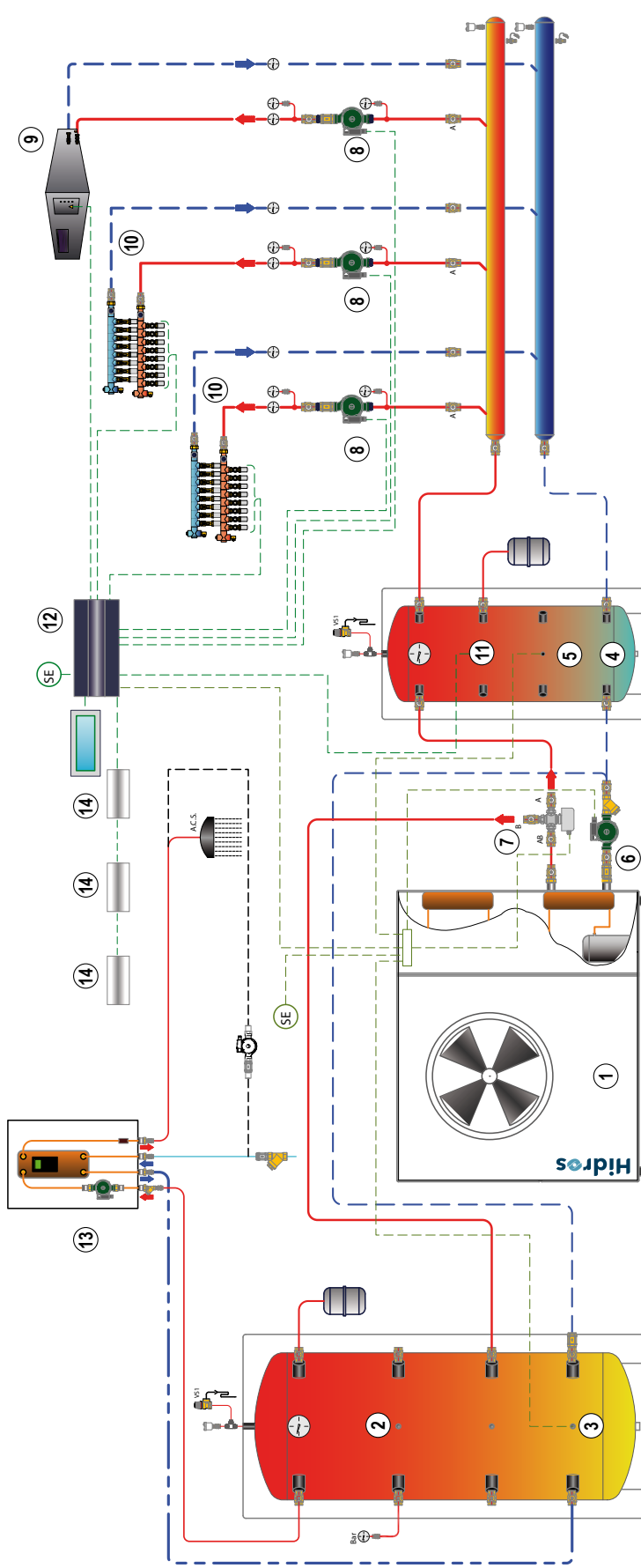

Installation of an air to water heat pump system. The system is equipped with weather -compensated ambient sensor. The Domestic hot water is produced using a 3 way diverting valve ( controlled by the unit microprocessor), a hot water storage tank and a hot water station with re-circulation. The DHW circuit has the priority.

The heating and cooling circuit comprises a hot and cold water storage tank, underfloor heating/cooling system and dehumidification controlled by Dehumidifiers for radiant cooling systems with heat recovery with cooling integration.

Supervision of the system is made by temperature/humidity sensors, connected in BUS line, programmable PLC with Modbus protocol and graphic display for the visualization of the different parameters.

The above scheme is for illustrative purposes only

<b>1</b>	Heat Pump	<b>4</b>	Buffer Tank	<b>7</b>	Diverting Valve	<b>10</b>	Zone Manifold	<b>13</b>	Heat Station
<b>2</b>	Hot Water Tank	<b>5</b>	Heating Sensor	<b>8</b>	Zone Pump	<b>11</b>	Min Temperature Sensor	<b>14</b>	Temperature Sensors
<b>3</b>	Hot Water Sensor	<b>6</b>	Heating Pump	<b>9</b>	Dehumidifier	<b>12</b>	Controller		

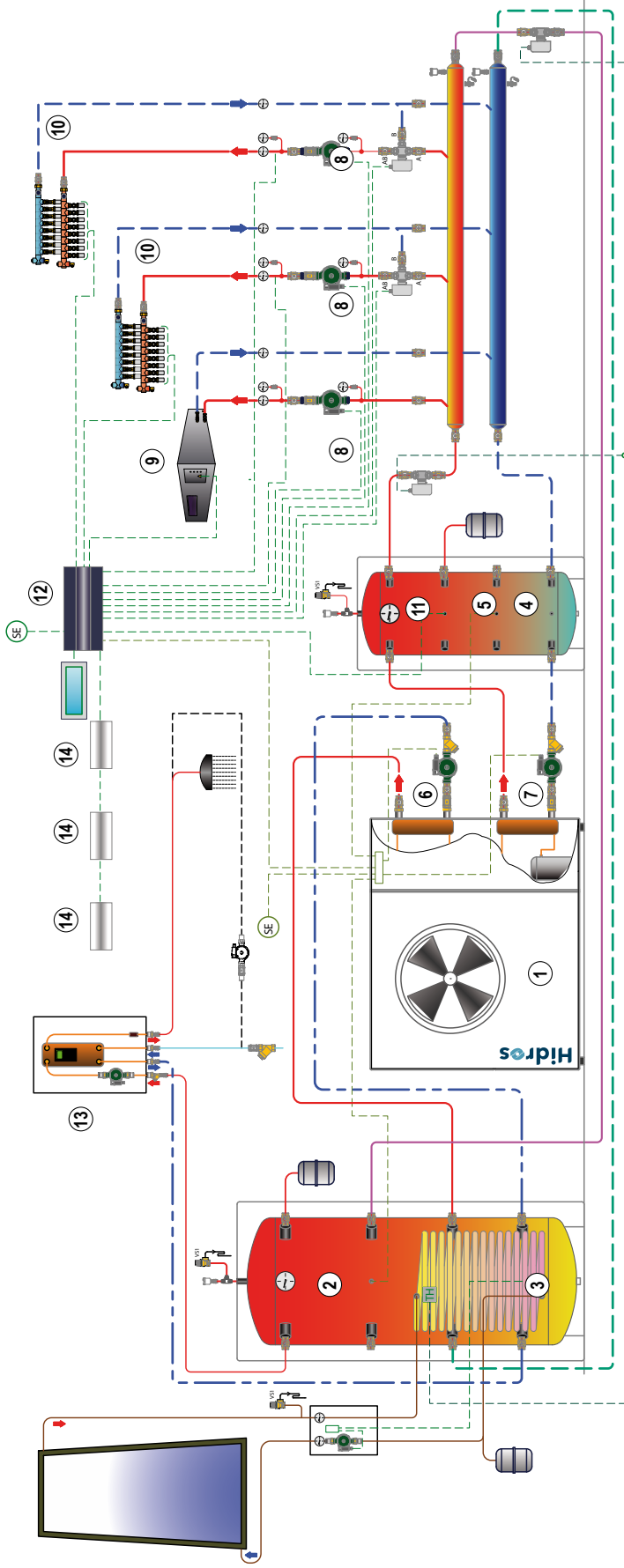

Installation of an air to water heat pump system 4 pipes version. The system is equipped with weather -compensated ambient sensor. The Domestic hot water is produced using a hot water storage tank with solar coil and a hot water station with re-circulation. The DHW circuit has the priority. The heating and cooling circuit comprises a hot and cold water storage tank, underfloor heating/cooling system and dehumidification controlled by Dehumidifiers for radiant cooling systems with heat recovery with cooling integration.

Integration of the solar system is possible either on the DHW circuit or the heating circuit, by using a "limit" thermostat to recover the surplus of energy on the DHW circuit. Supervision of the system is by temperature/humidity sensors with mixing valves for the management of the hot water temperature in winter mode and the cold water temperature in summer with respect to the ambient dew point. The sensors are connected in BUS line, programmable PLC with Modbus protocol and graphic display for visualization of the various parameters.

The above scheme is for illustrative purposes only

1	Heat Pump	4	Buffer Tank	7	Heating Pump	10	Zone Manifold	13	Heat Station
2	Hot Water Tank	5	Heating Sensor	8	Zone Pump	11	Min Temperature Sensor	14	Temperature Sensor
3	Hot Water Sensor	6	Hot Water Pump	9	Dehumidifier	12	Controller		



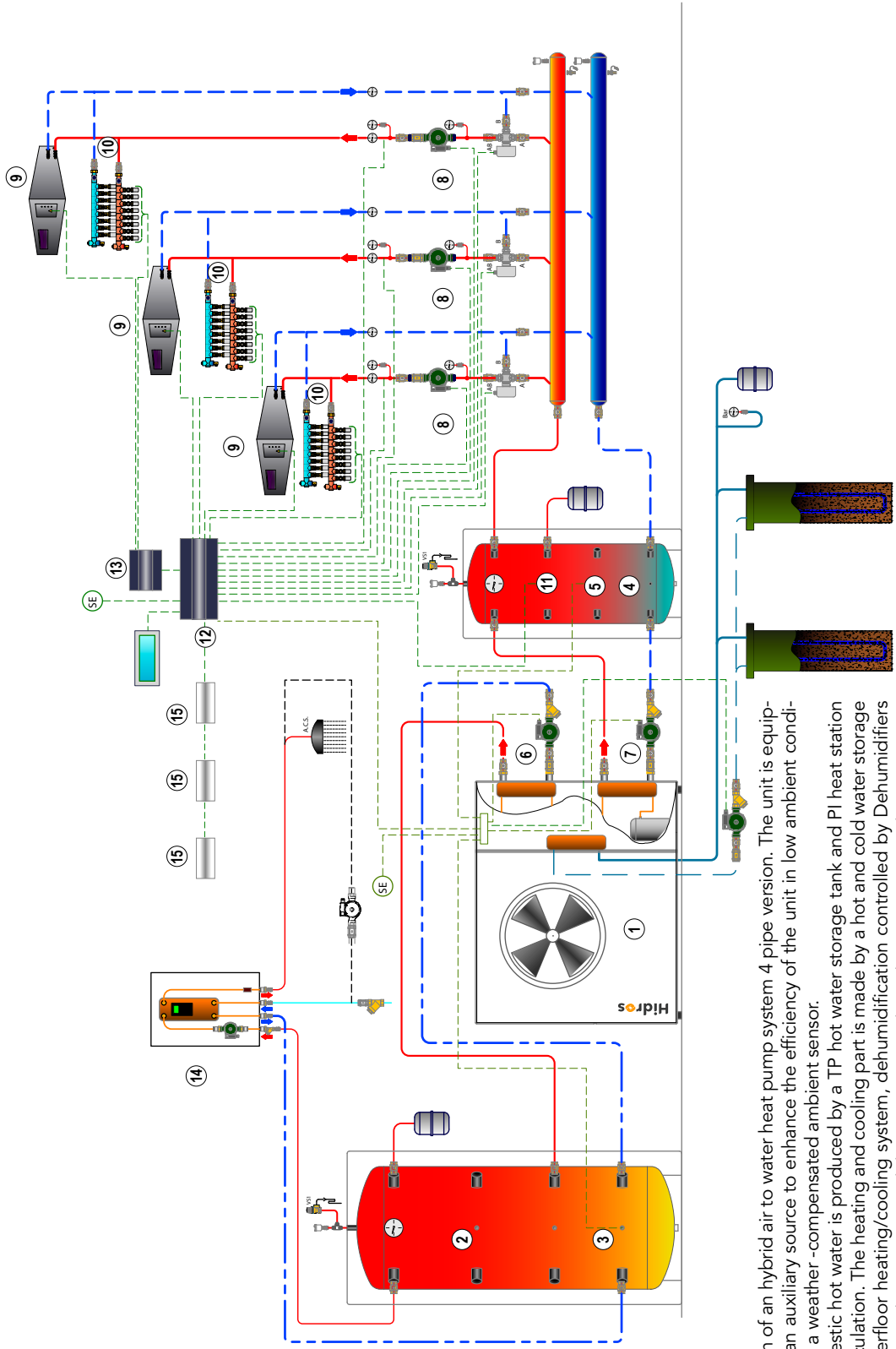

Installation of an hybrid air to water heat pump system 4 pipe version. The unit is equipped with an auxiliary source to enhance the efficiency of the unit in low ambient conditions, and a weather -compensated ambient sensor.

The Domestic hot water is produced by a TP hot water storage tank and PI heat station with recirculation. The heating and cooling part is made by a hot and cold water storage tank, underfloor heating/cooling system, dehumidification controlled by Dehumidifiers for radiant cooling systems with heat recovery with cooling integration. The supervision of the system is made by temperature/humidity sensors, connected in BUS line, programmable PLC with Modbus protocol and graphic display for the visualization of the different parameters.

The above scheme is for illustrative purposes only

<b>1</b>	Heat Pump	<b>4</b>	Buffer Tank	<b>7</b>	Diverting Valve	<b>10</b>	Zone Manifold	<b>13</b>	Expansion Module
<b>2</b>	Hot water Tank	<b>5</b>	Heating Sensor	<b>8</b>	Zone Pump	<b>11</b>	Min Temperature Sensor	<b>14</b>	Heat Station
<b>3</b>	Hot water Sensor	<b>6</b>	Heating Pump	<b>9</b>	Dehumidifier	<b>12</b>	Controller	<b>15</b>	Temperature Sensor



# FH - GH

## DEHUMIDIFIERS FOR RADIANT COOLING SYSTEMS

Dehumidifying capacity from 20 l/24h to 164 l/24h  
Air flow from 250 m<sup>3</sup>/h to 1850 m<sup>3</sup>/h

---

R407C

R134a



### FH



### GH



---

The dehumidifiers FH and GH series are high performance units, equipped with robust galvanised steel frame, properly designed to operate in combination with radiant cooling systems. The FH units have been designed for wall mounting installation while the GH series are suitable for false ceiling and ducted applications. All units are provided with air filter, stainless steel drip tray and built-in microprocessor control. The units are also provided, standard, with pre and post cooling coil to enhance the performances and to control the air supply temperature. FH and GH units, anyway, can operate even without pre and post cooling coils, this option could be very useful in middle seasons when it is necessary to dry but the air conditioning system is not in operation. All the units are fully assembled and wired in the factory, carefully evacuated and dried with after leak tests under pressure and they are charged with environmental friendly refrigerant gases. They are fully tested before shipment; the units are conform to European Directives and are individually marked with CE label and Conformity Declaration.

### VERSIONS

- WZ** Units supplied with double condenser (the first is an air condenser, the second is a water one) and of a logic which allows the dehumidification with neutrum air or with cooled air.

## TECHNICAL DATA

FH - FHWZ		25	25WZ
Moisture removed <sup>(1)</sup>	l/24h	20,1	20,1
Cooling capacity <sup>(1)</sup>	W	---	1250
Total power input <sup>(1)</sup>	W	360	360
Max power input	W	440	440
Max input current	A	2,7	2,7
Peak current	A	18,1	18,1
Air flow	m <sup>3</sup> /h	250	250
Refrigerant		R134a	R134a
Global warming potential (GWP)		1430	1430
Refrigerant charge	kg	0,2	0,6
Equivalent CO2 charge	t	0,36	0,89
Water flow	l/h	150	150
Pressure drop	kPa	8	7,8
Sound power <sup>(2)</sup>	dB(A)	45	45
Sound pressure <sup>(3)</sup>	dB(A)	37	37
Power supply	V/Ph/Hz	230/1/50	230/1/50

GH - GHWZ		25	25WZ	50	50WZ	100	100WZ	200	200WZ
Moisture removed <sup>(1)</sup>	l/24h	20,1	20,1	48,5	48,5	87,2	87,2	164,0	164,0
Cooling capacity <sup>(1)</sup>	W	---	1250	---	3500	---	6000	---	11300
Total power input <sup>(1)</sup>	W	340	340	700	700	1450	1450	2450	2450
Max power input	W	420	420	830	830	1690	1690	2890	2890
Max input current	A	2,7	2,7	5,0	5,0	8,1	8,1	14,4	14,4
Peak current	A	18,1	18,1	20,7	20,7	35,9	35,9	63,0	63,0
Water flow	l/h	150	150	500	500	600	600	900	900
Pressure drop	kPa	8,0	7,8	17,0	42,0	32,0	39,5	48,0	64,0
Air flow	m <sup>3</sup> /h	250	250	600	600	1000	1000	1850	1850
Available static pressure (max. speed)	Pa	43	43	60	60	75	75	120	120
Refrigerant		R134a	R134a	R407C	R407C	R407C	R407C	R407C	R407C
Global warming potential (GWP)		1430	1430	1774	1774	1774	1774	1774	1774
Refrigerant charge	kg	0,2	0,6	0,7	0,9	1,0	1,6	1,7	2,0
Equivalent CO2 charge	t	0,36	0,89	1,24	1,57	1,77	2,79	3,02	3,55
Sound power <sup>(2)</sup>	dB(A)	45	45	50	50	57	57	64	64
Sound pressure <sup>(3)</sup>	dB(A)	37	37	42	42	49	49	56	56
Power supply	V/Ph/Hz	230/1/50	230/1/50	230/1/50	230/1/50	230/1/50	230/1/50	230/1/50	230/1/50

Performances are referred to the following conditions:

(1)Room temperature 26°C; relative humidity 65% with cold water coil water inlet temp. 15°C.

(2)Sound power level in accordance with ISO 9614.

(3)Sound pressure level measured at 1 mt from the unit in free field conditions according to ISO 9614, minimum fan speed.(Only for FH versions)

## COMPONENTS

### FRAME

All units FH-GH series are made from hot-galvanised thick sheet metal, to ensure the best resistance against the corrosions. The frame is self-supporting with removable panels. The drip tray is present standard in all units and is made of plastic material for model 25 and in metal material for models 50-100-200.

### REFRIGERANT CIRCUIT

The refrigerant circuit is made by using international primary brands components and according to ISO 97/23 concerning welding procedures. The refrigerant gas used in these units is R134a for the model 25 and R407C for the models 50-100-200. The refrigerant circuit includes: filter drier, capillary expansion device, Schrader valves for maintenance and control, pressure safety device (according to PED regulation).

### COMPRESSOR

The compressor (for model 25) is alternative or rotative type (for models 50-100-200), equipped with crankcase heater and thermal overload protection by a klixon embedded in the motor winding. It's mounted on rubber vibration dampers to reduce the noise.

### CONDENSER AND EVAPORATOR

The condensers and evaporators are made of copper pipes and aluminium fins. The diameter of the copper pipes is 3/8" and the thickness of the aluminium fins is 0,1 mm. The tubes are mechanically expanded into the aluminium fins to improve the heat exchange factor. The geometry of these condensers guarantees a low air side pressure drop and then the use of low rotation (and low noise emission) fans. All the units have a stainless steel drip tray. Besides this, each evaporator is supplied of a temperature probe used as automatic antifreeze probe. In all units WZ besides these exchangers, there is a third stainless steel INOX AISI 316 plate exchanger used as condenser in cooling modality, powered by the plant water.

### PRE AND POST WATER COOLING COILS

The pre and post cold water coils are made of copper pipes and aluminium fins. The diameter of the copper pipes is 3/8" and the thickness of the aluminium fins is 0,1 mm. The tubes are mechanically expanded into the aluminium fins to improve the heat exchange factor. The pre-cooling coil is used to increase the dehumidification capacity of the unit, while the post-cooling coil is used to keep the outlet air temperature at the same inlet value. In WZ version only the pre cooled water coil is present.

## FAN

The supply fan is centrifugal type, double inlet with forwards blades, dynamically and statically balanced and directly connected to a 3 speed fan motor.

## AIR FILTER

For the model GH 25-50 it's supplied standard with the unit and it's built in nylon. It can be removed for differential disposal, class coarse 30%, according to UNI EN ISO 16890:2017. Regarding the model 100 and 200, it's made of filtering material in synthetic fibre without electrostatic charge. It can be removed for differential disposal and is class coarse 60% according to UNI EN ISO 16890:2017.

## MICROPROCESSOR

All units FH-GH are supplied standard with microprocessor controls. The microprocessor controls the following functions: compressor timing, automatic defrost cycles and alarms. An appropriate LCD display shows the operation mode of the unit, set point and alarms.

## ELECTRIC BOX

The electric switch board is made according to electromagnetic compatibility norms CEE 2014/35 and 2014/30. The accessibility to the board is possible after removing the front panel of the unit. Ready for the connection to the power and to the consensus control, The terminal board is also supplied with voltage free contacts for remote ON-OFF. The terminal block is also built with a clean contact to allow the operation of single-mode ventilation, while the second for the cooling version (WZ). By closing the first contact, only the fan is able to work, while the dehumidification is disabled.

## CONTROL AND PROTECTION DEVICES

All units are supplied with the following control and protection devices: defrost thermostat, which signals to the microprocessor control that a defrost cycle is needed and controls its termination (only for GH100-100WZ and GH200-200WZ).

Water temperature sensor, that signals to the microprocessor the eventual overcome of the hot water temperature set point in the pre and post water coils during operation. In this condition the compressor is disconnected while the fan always run and, when the water temperature returns within the operation limits, restarts the compressor.

The water sensor stops the compressor when the water temperature is above 35°C. The eventual use of the dehumidifier as heating device during winter season requires an additional remote thermostat with seasonal change over (not supplied). In the all WZ version, it's also supplied a high pressure switch which disable the unit operation when the limit is overcome.

## TEST

All the units are fully assembled and wired at the factory, carefully evacuated and dried after leak tests under pressure and then charged with ecologic refrigerant.

They are all fully operational tested before shipment. They all conform to European Directives and are individually marked with the CE label and provided with Conformity Declaration.

## MAIN COMPONENTS

STANDARD VERSION

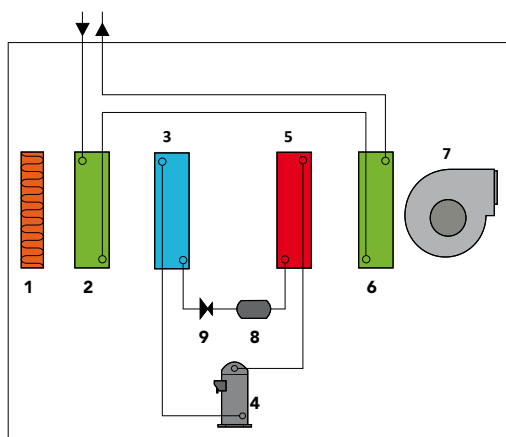

1	Air filter
2	Pre-cooling coil
3	Evaporator
4	Compressor
5	Condenser

WZ VERSION

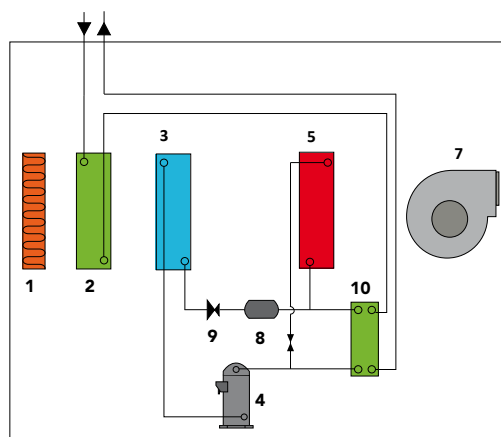

6	Post-cooling coil
7	Fan
8	Dry filter
9	Expansion device
10	Condenser water

## REFRIGERANT CIRCUIT STANDARD VERSION

The functioning of the dehumidifier model FH-GH is as follows: the fan takes the air from the ambient (7) and it's made go through the filter (1) and the pre-cooling water coil (2) where it's cooled and brought to a condition closed to saturation. Now it passes through the evaporating coil (3) where it's further cooled

and dehumidified. The air passes now through the condensing coil (5) where it's post heated (with a constant humidity) and in the post-cooling coil (6) where it's reported to the required conditions.

All the dehumidifiers model FH-GH can work without the help of the pre and post cooling coils. This function is very useful in

case there is the request of dehumidification in middle-season or when the chiller is off. Obviously, if the unit works without the help of the cold water, the air in outlet will be hotter than the air in inlet.

### REFRIGERANT CIRCUIT WZ VERSION

The operation of the dehumidifier model GH is as follows: the fan takes the air from the ambient (7) and it's made go through the filter (1) and the pre-cooling water coil (2) where it's cooled and brought to a condition closed to saturation. Now it passes through the evaporating coil (3) where it's fatherly cooled and dehumidified.

At this point there are two possible modalities:

#### Modality with neutrum air.

The air passes now through the condensing coil (5) which allows to condensate the 50% of the total gas, (the unit condensate the

50% on air with the heat exchanger (5) and the 50% in water with the heat exchanger (10)) then there is the post-heating so that to avoid to send air in the ambient in neutrum thermic conditions.

#### Modality with cooled air.

The unit condensates the 100% in water through the heat –exchanger (10). The air, then, go through the condenser (5) (disabled) where does not change its characteristics (temperature and humidity).

## ACCESSORIES

FH - FHWZ		25	25WZ
Limit probe		●	●
High pressure switch		–	●
Galvanized steel template	CTFH	○	○
Wood return and supply grill	GRFH	○	○
Remote mechanical hygostat	HYGR	○	–
Remote mechanical hygostat + thermostat	HYGR	–	○

● Standard, ○ Optional, – Not available.

GH - GHWZ		25	25WZ	50	50WZ	100	100WZ	200	200WZ
Limit probe		●	●	●	●	●	●	●	●
High pressure switch		–	●	–	●	–	●	–	●
Defrost thermostat		–	–	–	–	●	●	●	●
Remote mechanical hygostat	HYGR	○	–	○	–	○	–	○	–
Remote mechanical hygostat + thermostat	HYGR	–	○	–	○	–	○	–	○
Delivery and return plenum 90°	CANA	○	○	○	○	–	–	–	–

● Standard, ○ Optional, – Not available.

## GH

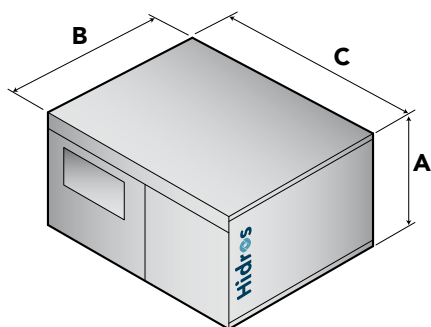

Mod.	A(mm)	B(mm)	C(mm)	kg
25	257	582	582	35
50	352	582	582	52
100	392	800	730	87
200	464	888	930	115
25WZ	257	582	582	37
50WZ	352	582	582	55
100WZ	392	800	730	90
200WZ	464	888	930	120

## FH

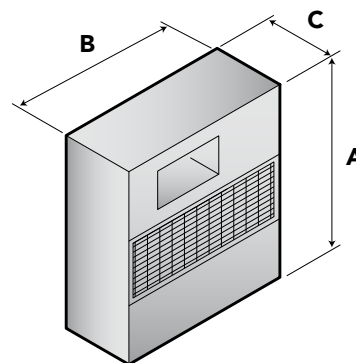

	A (mm)	B (mm)	C (mm)	kg
FH	681	545	223	38
FH WZ	681	545	223	45

# GHE

## DEHUMIDIFIERS FOR RADIANT COOLING SYSTEMS WITH HEAT RECOVERY

Dehumidifying capacity from 30,1 l/24h to 61,8 l/24h  
Air flow from 130 m<sup>3</sup>/h to 500 m<sup>3</sup>/h

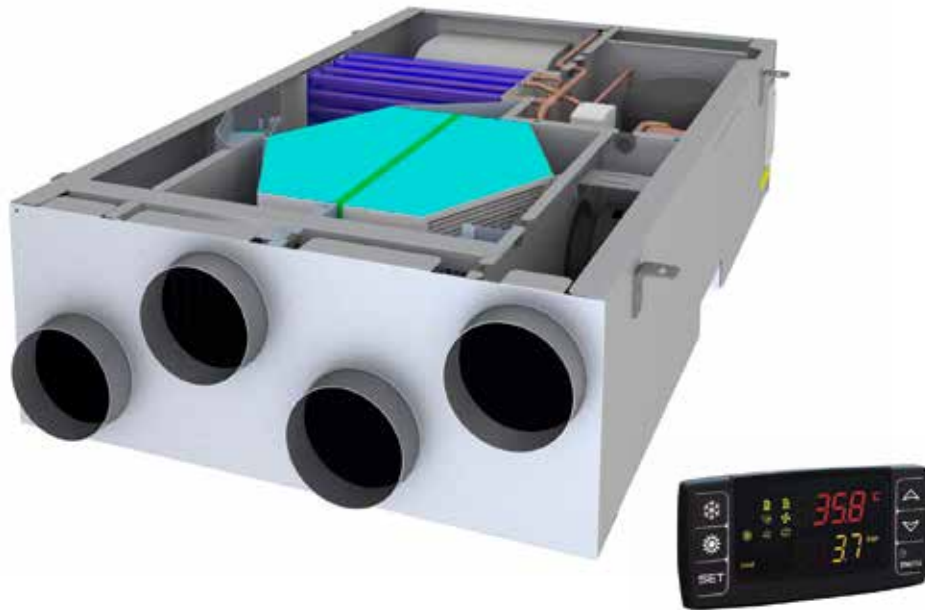

R134a

R410A



The dehumidifiers with heat recovery of high efficiency series GHE were designed to provide dehumidification and fresh air in a residential area with very high energy efficiency, combined with radiant cooling systems.

The units have been designed to grant the dehumidification either under conditions of thermally neutral air or in terms of air-cooled, managing small air flow thus avoiding annoying tiny air currents typical of traditional air conditioning systems.

The units consist of a direct expansion cooling system combined with a cross flow heat exchanger highly efficient, designed for heat recovery and air exchange environment in compliance with applicable regional and national laws.

### VERSIONS

**FC Free Cooling:** allows the air to avoid unnecessary switching on the cooling circuit, thus granting excellent environmental conditions with high energy savings. The Free Cooling option is perfect in the middle seasons, when heating or cooling systems are not in use.

## TECHNICAL DATA

GHE		26	51
Useful dehumidification capacity (from the net hygroscopic content of the external air) <sup>(1)</sup>	l/24h	30,1	61,8
Total cooling Power (latent + sensible) <sup>(1)</sup>	W	1380	2820
Recovered winter heating power <sup>(2)</sup>	W	950	1850
Efficiency winter recovery <sup>(2)</sup>	%	90	90
Efficiency summer recovery <sup>(1)</sup>	%	75	72
Power supply	V/Ph/Hz	230/1/50	230/1/50
Compressor absorbed power <sup>(1)</sup>	W	340	480
Supply fan absorbed power: minimum÷nominal÷maximum	W	10 ÷ 30 ÷ 86	30 ÷ 60 ÷ 130
Return fan absorbed power	W	11 ÷ 22 ÷ 43	22 ÷ 44 ÷ 68
Supply fan nominal useful prevalence	Pa	50 ÷ 140	50 ÷ 140
Return fan nominal useful prevalence	Pa	50 ÷ 140	50 ÷ 140
Min-max coil water flow	l/h	150 ÷ 250 ÷ 400	200 ÷ 350 ÷ 600
Min-max water pressure drop	kPa	15	35
Outdoor air flow	m <sup>3</sup> /h	80 ÷ 130	140 ÷ 250
Supply air flow	m <sup>3</sup> /h	130 ÷ 260	250 ÷ 500
Refrigerant		R134a	R410A
Global warming potential (GWP)		1430	2088
Refrigerant charge	kg	0,64	1,10
Equivalent CO2 charge	t	0,92	2,30
Sound power <sup>(3)</sup>	dB(A)	61	66
Sound Pressure <sup>(4)</sup>	dB(A)	47	52

Performances are referred to the following conditions:

(1) Room Temp. 26°C; 65% RU; Ambient Temp. 35°C; 50% RU; Fresh Air System volume 130 m<sup>3</sup>/h (GHE26), 250 m<sup>3</sup>/h (GHE51); Water IN 15°C, Water Flow 250 l/h (GHE26), 350 l/h (GHE51).

(2) Ambient Temp. -5°C; 80% RU; Room Temp. 20°C; Fresh Air system at maximum.

(3) Sound Power level according to ISO 9614.

(4) Sound Pressure level measured at 1 mt from the unit in free field conditions according with ISO 9614, at the normal working conditions.

## TYPICAL INSTALLATION

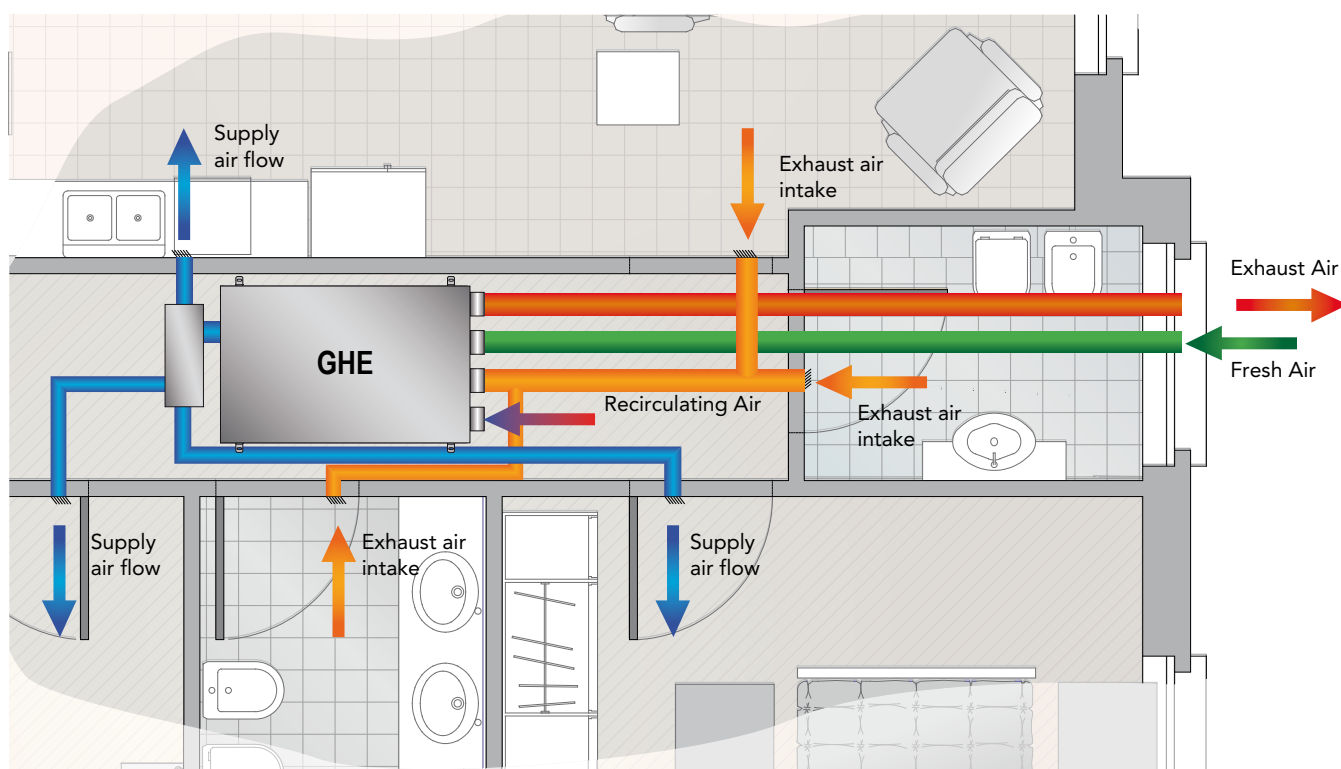

# COMPONENTS

## FRAME

All units are made from hot-galvanised thick sheet metal, to ensure the best resistance against the corrossions. The frame is self-supporting with removable panels. The drip tray is present standard in all units.

## REFRIGERANT CIRCUIT

The refrigerant circuit is made by using international primary brands components and according to ISO 97/23 concerning welding procedures. The refrigerant gas used in these units is R134a for the model 26 and R407C for the models 51.

## COMPRESSOR

The compressor is alternative for model 26 and rotative type for model 51, equipped and thermal overload protection by a klixon embedded in the motor winding. It's mounted on rubber vibration dampers to reduce the noise.

## HEAT EXCHANGERS

The heat exchangers are made of copper pipes and aluminium fins. The diameter of the copper pipes is 3/8" and the thickness of the aluminium fins is 0,1 mm. The tubes are mechanically expanded into the aluminium fins to improve the heat exchange factor. The geometry of these condensers guarantees a low air side pressure drop and then the use of low rotation (and low noise emission) fans. All the units have a stainless steel drip tray. Besides this, each evaporator is supplied of a temperature probe used as automatic antifreeze probe.

## FANS

The supply fan is centrifugal type, double inlet with forwards blades, with EC Fan motor directly connected. The exhaust fan is plug fan type with backwards blades, with EC fan motor directly connected.

## AIR FILTER

It's supplied standard with the unit. It's made of filtering material in synthetic fibre without electrostatic charge. It can be removed for differential disposal, ePM10 50% according to UNI EN ISO 16890:2017.

## HEAT RECOVERY

Hexagonal cross-flow heat recovery with PVC plates, high efficiency (90%).

## Adjustment micro switches

Used during calibration of fans air flow depending on the ducts pressure drop .

## MICROPROCESSOR

All GHE units are supplied with an advanced software for the complete control of the hydronic and air distribution side.

The software can manage:

- The management of the operation according to a probe of temperature and humidity.
- Activation of the dehumidification based on the pre set humidity conditions.
- Activation of of winter or summer sensible load integration, according to the summer or winter set point
- Management of supply air temperature through discharge limit probe sensor (standard).
- Modulating valve for the proper management of the water battery power
- Ventilation Management directly from built-in timer in the microprocessor (optional).
- Management damper
- Machine Allarm display
- Supervisor and BMS connection through serial card RS485 (Optional) a/o XWEB Module (Optional).
- Clogged filters management (optional).
- Antifreeze management.
- Summer/Winter commutation.

## VERSIONS

### Free Cooling (FC)

In these versions, the electronic control mounted on the machine, check the thermo-hygrometric conditions (indoor –outdoor), allows the air to avoid unnecessary switching on of the refrigerating circuit, thus ensuring excellent environmental conditions with high energy savings. The Free Cooling option is perfect in spring and autumn, when heating or cooling is not yet activated, or at night when the summer heat humidity conditions outside are often sufficient to ensure proper ventilation of rooms without the use of the refrigerant system.

## REFRIGERANT CIRCUIT FUNCTIONING PRINCIPLES

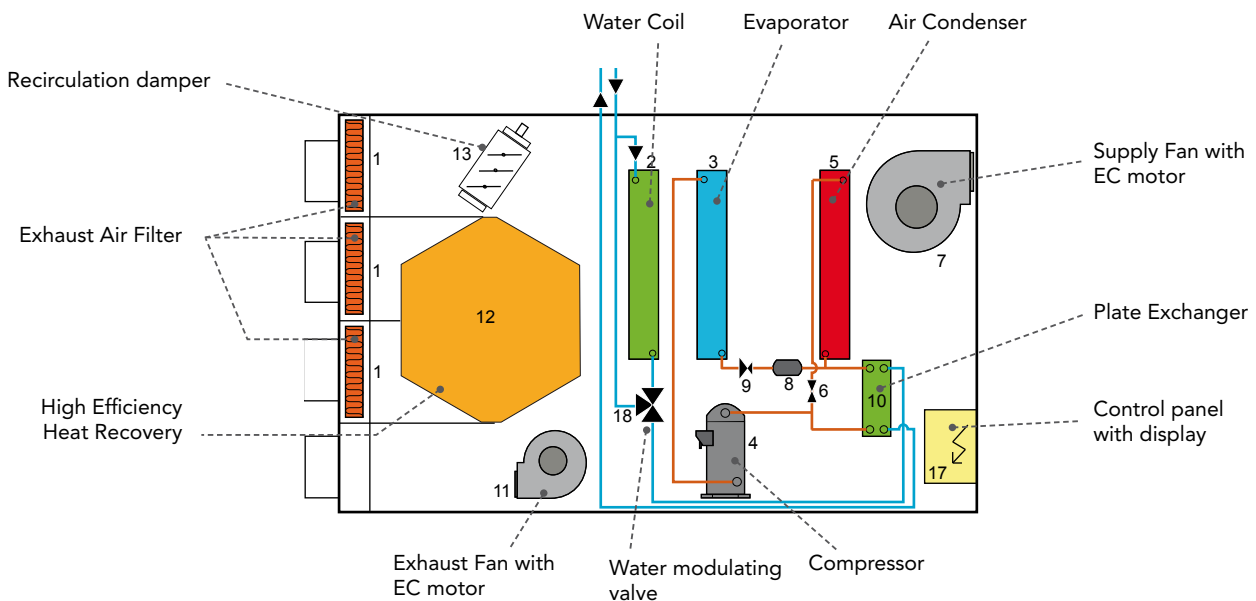



The functioning of the dehumidifier model GHE is as follows: the fan takes the air humid from the ambient through the fan (7) and it's made go through the filter (1) and the cross-flow heat (12) pre-cooling water coil (2) where it's cooled and brought to a condition closed to saturation. Now it passes through the evaporating coil (3) where it's fatherly cooled and dehumidified. At this time the functionality mode may be. The air passes now through the condensing coil (5) where it's post heated (with a constant humidity) and in cooling, when the solenoid valve (6) open where it's reported to the required conditions.

**Dehumidification with cooling:**

The cooling circuit, in this case, performing works 100% of the condensation in the water through the plate exchanger (10), the air condenser (5) is intercepted by the valve (6) and the air supplied in the room is the same as leaving the evaporator coil (3), cold and dried.

**Dehumidification with neutral air:**

The cooling system works partially in the water through the plate exchanger (10) and partially in the air with the air condenser (5) which will then make a post-heating at constant humidity blowing air in in the room in thermally neutral conditions.

**AERAUIC CIRCUIT FUNCTIONING PRINCIPLES:**

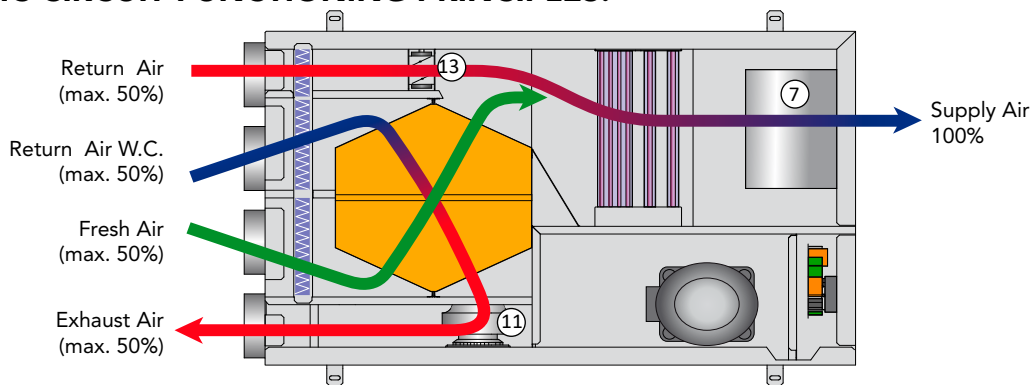

GHE 26 units can operate with a flow rate of outdoor air from 80 to 130 m<sup>3</sup>/h (140 to 260 m<sup>3</sup>/h for the model GHE 51), to ensure sufficient supply air changes in the room having a variable volume by 260 m<sup>3</sup> (0.5 vol/h) to 460 m<sup>3</sup> (0.3 vol/h), in compliance with regional and national regulations. The air flow rate of discharge can vary from 80 to 130 m<sup>3</sup>/h (140-260 m<sup>3</sup>/h for the model 51) in the winter mode, and is fixed to 260 m<sup>3</sup>/h (500 m<sup>3</sup>/h for the model 51) in summer mode. The cross-flow heat exchanger of high efficiency is designed to ensure a recovery

rating of 90% in terms of air temperature -5°C and air temperature 20°C. The stale air is expelled from the environment by the fan (11), while the outside air is sucked through the fan (7). The proper balance of air flows is ensured by the damper (13) that handles both the balance of flows of air that the air flow recirculation summer.

**SUMMER OPERATION (COMPRESSON ON)**

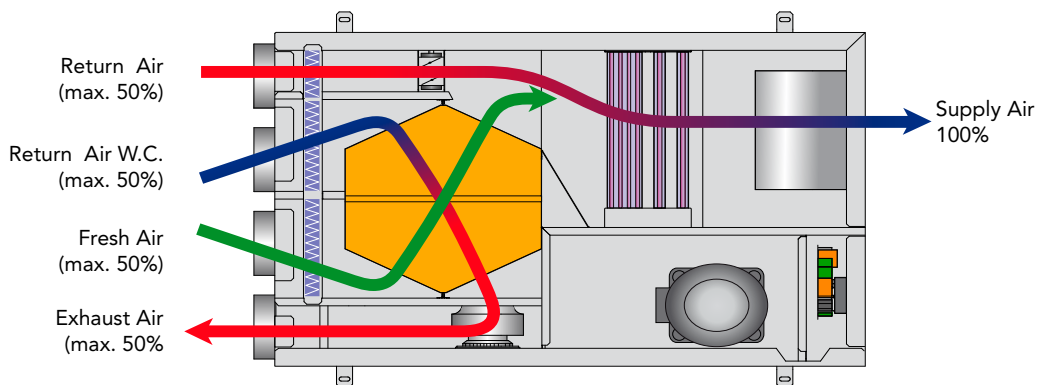

When this selected mode the unit renews the ambient air with the outside through the heat exchanger for high efficiency, air flow is increased so as to allow operation of refrigerant circuit; for this purpose the recirculating damper will be open, the supply fan is operated at maximum capacity and the unit works with external air and partial recirculation.

#### The possible functions in this configuration are

- Renewal + Air Dryers neutral: The condensing unit partially in air and partially in the water through the condenser plate, obtaining dry air and thermally neutral.
- Renewal + Dehumidification with cooling: The unit operates with 100% of the condensation water, obtaining dry and cooled air.

## WINTER OPERATION AND MIDDLE SEASON (COMPRESSOR OFF)

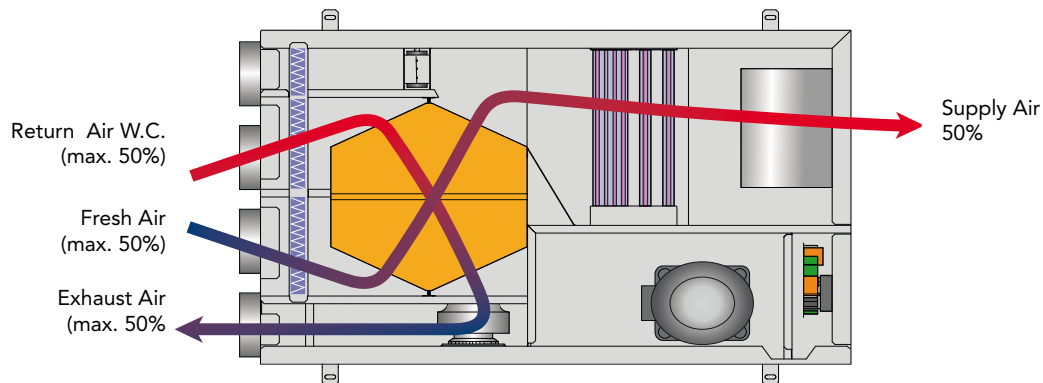

When this selected mode, the unit renews the ambient air with the outside through the heat exchanger of high efficiency. The air flow is reduced to the value required by the standard (0.3 ÷ 0.5 vol/h), the recirculation damper is closed and the unit operates with 100% fresh air.

#### The possible functions in this configuration are

- Renewal with heated air: The compressor is switched off, the battery can be supplied with hot water from radiant system. (even due to the high efficiency of the heat exchanger, is able to obtain a supply air temperature 17°C, without using hot water and ambient air temperature of -5°C), and behaves like a normal air handling with recovery.

## FRESH AIR WITH FREE COOLING (ONLY FC VERSION)

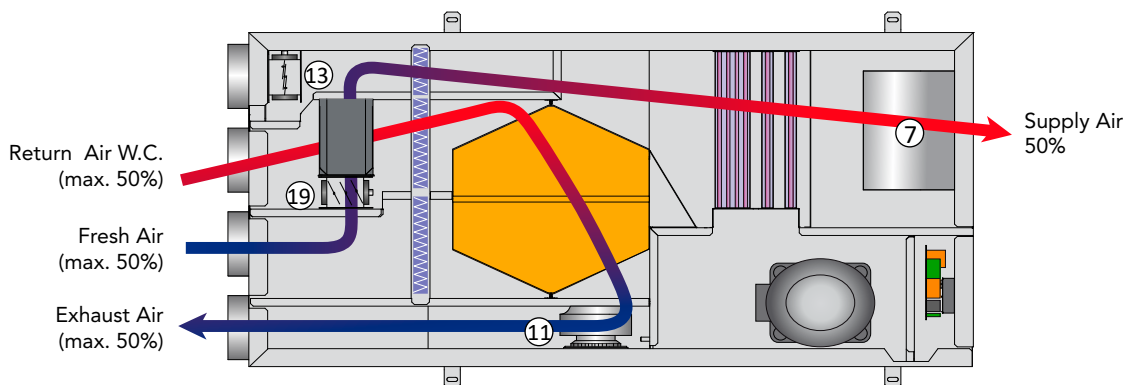

The compressor is off, the water coil is not powered (3-way valve closed), the recirculation damper (13) is closed, the damper by-pass of the recuperator (19) is open. The stale air is fully exhausted into the environment by the fan (11) Meanwhile outside air is sucked by the fan (7) bypasses the heat recovery and comes at

the room with temperature and relative humidity without modification. During the free cooling mode the flow rate of outside air is equal to the flow rate of the supply air in the environment.

## ACCESSORIES

GHE		26	51
Microprocessor control		●	●
User flow switch		●	●
Modulating 3-way valve		●	●
Supply & Return EC fans		●	●
G4 air filter		●	●
Adjustable Trimmers		●	●
High Efficiency Heat Recovery		●	●
Remote control Panel	PCRL	○	○
Thermo- Mechanical remote Hygrostat	HYGR	○	○
Humidity and Temperature electronic probe sensor	RGDD	○	○
Serial interface card RS485	INSE	○	○
High efficiency electronic air filter	FC	○	○

● Standard, ○ Optional, – Not available.

## SUMMER AIR TREATMENT

<span style="color: orange;">—</span>	Recovery
<span style="color: yellow;">—</span>	Mix flow
<span style="color: green;">—</span>	Pre-Cooling
<span style="color: blue;">—</span>	Evaporator
<span style="color: red;">—</span>	Condenser (if active)

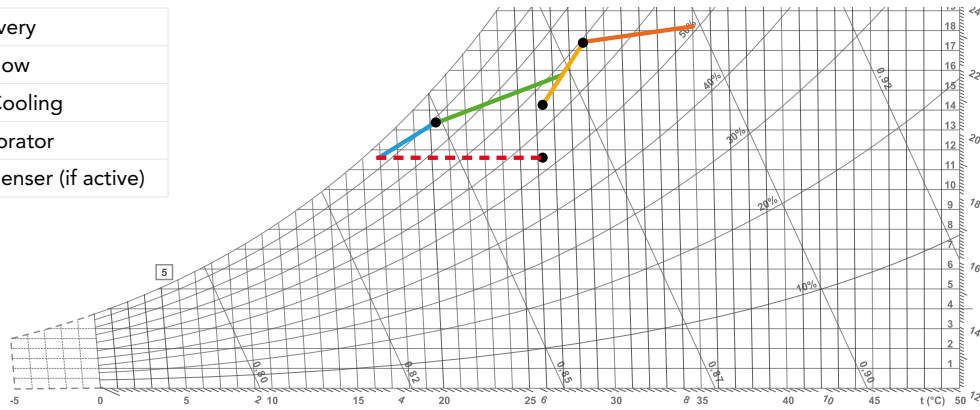

Standard version

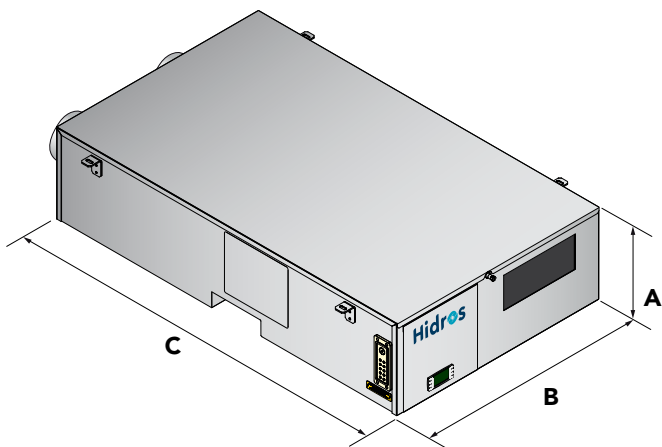

FC version

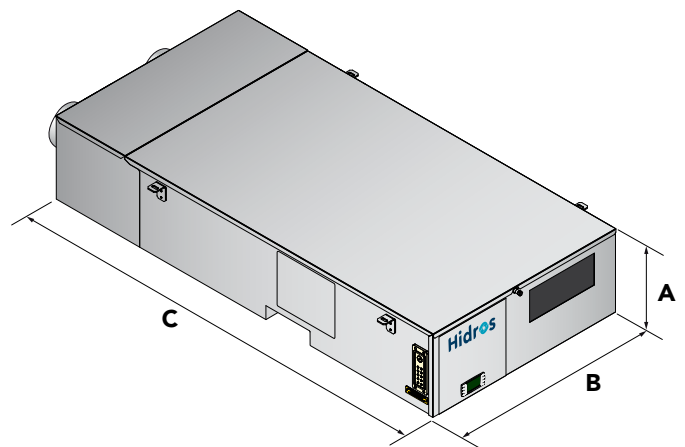

Mod.	A (mm)	B (mm)	C (mm)	kg
<b>26</b>	260	732	1105	60
<b>51</b>	400	835	1370	80
<b>26/FC</b>	260	732	1355	95
<b>51/FC</b>	400	835	1645	115

# FHE

## DEHUMIDIFIERS FOR RADIANT COOLING SYSTEMS WITH HEAT RECOVERY

Dehumidifying capacity 30 l/24h  
Air flow from 130 m<sup>3</sup>/h to 260 m<sup>3</sup>/h

---

R134a



The dehumidifiers with heat recovery of high efficiency series FHE were designed to provide dehumidification and fresh air in a residential area with very high energy efficiency, combined with radiant cooling systems.

The units have been designed to grant the dehumidification either under conditions of thermally neutral air or in terms of air-cooled, managing small air flow thus avoiding annoying tiny air currents typical of traditional air conditioning systems.

The units consist of a direct expansion cooling system combined with a cross flow heat exchanger highly efficient, designed for heat recovery and air exchange environment in compliance with applicable regional and national laws.

### VERSIONS

All units are supplied with double condenser (the first is an air condenser, the second is a water one) and of a logic which allows the dehumidification with neutral air or with cooled air.

## TECHNICAL DATA

FHE		26
Useful dehumidification capacity (from the net hygroscopic content of the external air) <sup>(1)</sup>	l/24h	30,1
Total cooling Power (latent + sensible) <sup>(1)</sup>	W	1380
Recovered winter heating power <sup>(2)</sup>	W	950
Efficiency winter recovery <sup>(2)</sup>	%	90
Efficiency summer recovery <sup>(1)</sup>	%	70
Power supply	V/Ph/Hz	230/1/50
Compressor absorbed power <sup>(1)</sup>	W	340
Supply fan absorbed power: minimum÷nominal÷maximum	W	10 ÷ 30 ÷ 86
Return fan absorbed power	W	11 ÷ 22 ÷ 43
Supply fan nominal useful prevalence	Pa	50 ÷ 140
Return fan nominal useful prevalence	Pa	50 ÷ 140
Min-max coil water flow	l/h	150 - 250 ÷ 400
Min-max water pressure drop	kPa	15
Outdoor air flow	m <sup>3</sup> /h	80 ÷ 130
Supply air flow	m <sup>3</sup> /h	130 ÷ 260
Refrigerant		R134a
Global warming potential (GWP)		1430
Refrigerant charge	kg	0,59
Equivalent CO2 charge	t	0,84
Sound power <sup>(3)</sup>	dB(A)	61
Sound Pressure <sup>(4)</sup>	dB(A)	47

Performances are referred to the following conditions:

(1)Room Temp. 26°C; 65% RU; Ambient Temp. 35°C; 50% RU; Fresh Air System volume 130 m<sup>3</sup>/h; Water IN 15°C, Water Flow 250 l/h.

(2)Ambient Temp. -5°C; 80% RU; Room Temp. 20°C; Fresh Air system at maximum.

(3)Sound Power level according to ISO 9614.

(4)Sound Pressure level measured at 1 mt from the unit in free field conditions according with ISO 9614, at the normal working conditions.

## TYPICAL INSTALLATION

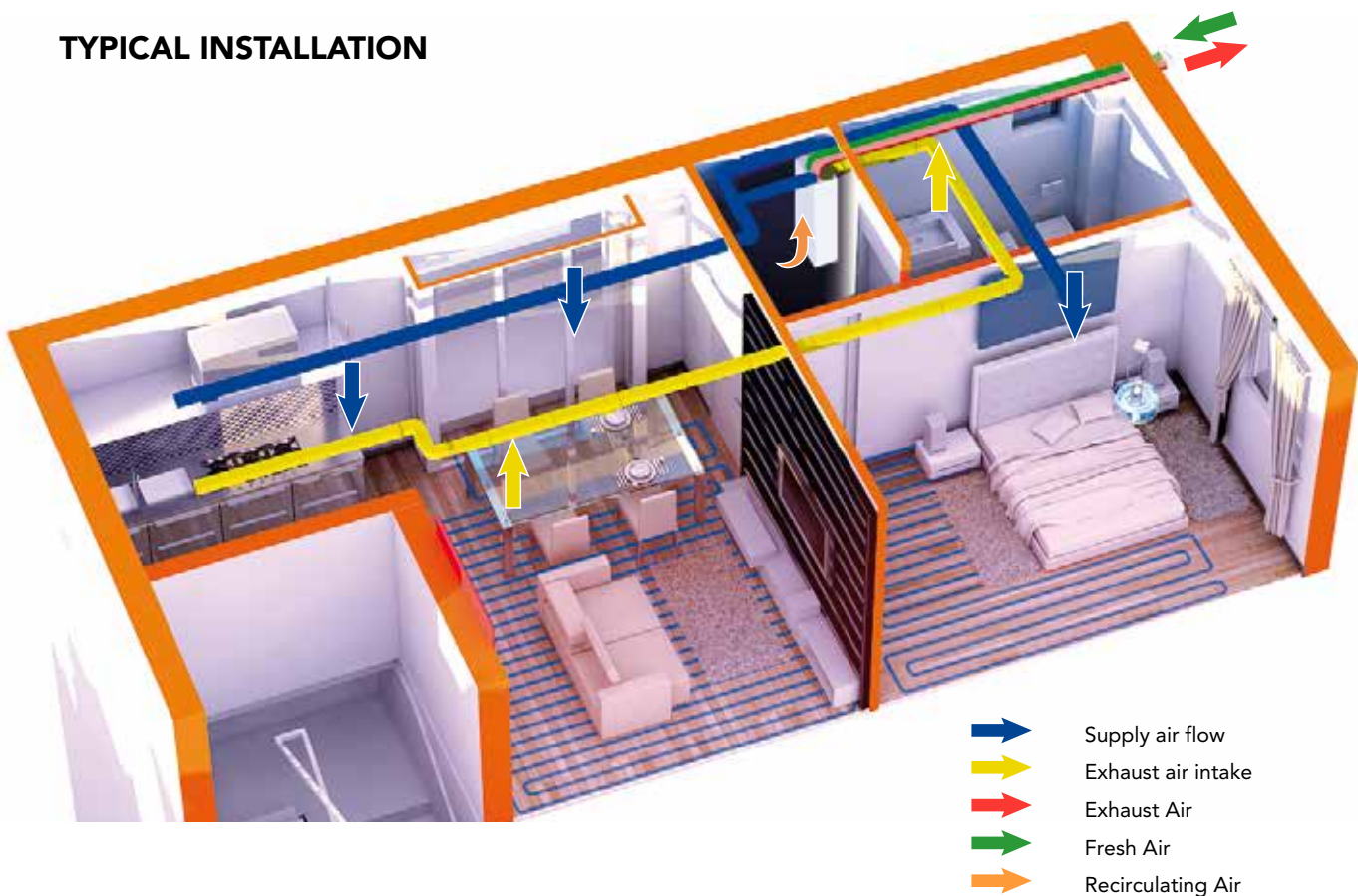

## COMPONENTS

### FRAME

All units are made from hot-galvanized thick sheet metal, painted with polyurethane powder enamel and stoved at 180°C to ensure the best resistance against the corrosions. The frame is self-supporting with removable panels. The drip tray is made in painted galvanized steel and it is present in all units. The standard colour is RAL 9010.

### REFRIGERANT CIRCUIT

The refrigerant circuit is made by using international primary brands components and according to ISO 97/23 concerning welding procedures. The refrigerant gas used in is R134a.

### COMPRESSOR

The compressor is alternative type equipped and thermal over-load protection by a klixon embedded in the motor winding. It's mounted on rubber vibration dampers to reduce the noise.

### HEAT EXCHANGERS

The heat exchangers are made of copper pipes and aluminium fins. The diameter of the copper pipes is 3/8" and the thickness of the aluminium fins is 0,1 mm.

### FANS

The supply fan is centrifugal type, double inlet with forwards blades, with EC Fan motor directly connected. The exhaust fan is plug fan type with backwards blades, with EC fan motor directly connected.

### AIR FILTER

It's supplied standard with the unit. It's made of filtering material in synthetic fibre without electrostatic charge. It can be removed for differential disposal, ePM10 50% according to UNI EN ISO 16890:2017.

### Heat recovery

Hexagonal cross-flow regenerator with PVC plates, high efficiency (90%).

### ADJUSTMENT TRIMMERS

Used during calibration of fans air flow depending on the ducts pressure drop .

### MICROPROCESSOR

All FHE units are supplied with an advanced software for the complete control of the hydronic and air distribution side.

The software can manage:

- The management of the operation according to a probe of temperature and humidity.
- Activation of the dehumidification based on the pre set humidity conditions.
- Activation of winter or summer sensible load integration, according to the summer or winter set point
- Management of supply air temperature through discharge limit probe sensor (standard).
- Modulating valve for the proper management of the water battery power.
- Ventilation Management directly from built-in timer in the microprocessor (optional).
- Management damper
- Machine alarm display
- Supervisor and BMS connection through serial card RS485 (Standard fitted) a/o XWEB Module (Optional).
- Clogged filters management (optional).
- Antifreeze management.
- Summer/Winter commutation.

## MAIN COMPONENTS

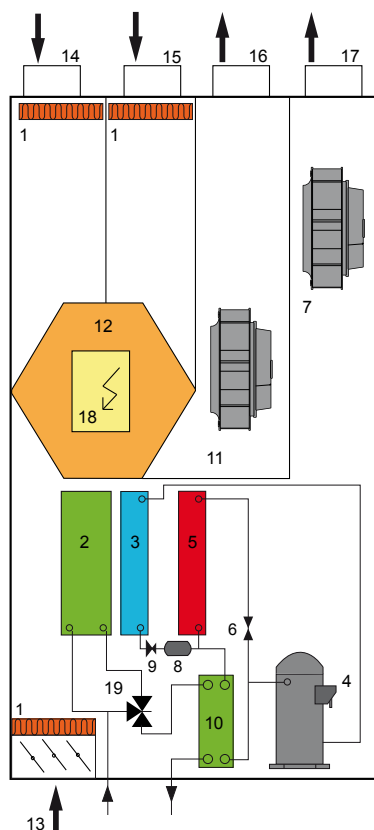

1	Air filter
2	Pre-Cooling coil
3	Evaporator
4	Compressor
5	Air Condenser
6	Solenoid Valve
7	Supply fan with EC
8	Dryer Filter
9	Body rolling
10	Water condenser
11	Exhaust fan with EC motor
12	High efficiency cross-flow heat recovery
13	Return motorized damper
14	WC exhaust air
15	Fresh air
16	Exhaust Air
17	Supply air flow
18	Electrical Panel
19	Modulating 3-way valve

## REFRIGERANT CIRCUIT FUNCTIONING PRINCIPLES

The functioning of the dehumidifier model FHE is as follows: the fan takes the air humid from the ambient through the fan (7) and it's made go through the filter (1), the cross-flow heat (12) and the pre-cooling water coil (2) where it's cooled and brought to a condition closed to saturation.

Now it passes through the evaporating coil (3) where it's fatherly cooled and dehumidified.

At this time the functionality mode may be:

### Dehumidification with neutral air :

The cooling system works partially in the water through the heat exchanger (10) and partially in the air with the heat exchanger (5) which will then make a post-heating at constant humidity blowing air in the room in thermally neutral conditions.

### Dehumidification with cooling:

The cooling circuit, in this case, works performing 100% of the condensation in the water through the heat exchanger (10).The heat exchanger (5) is intercepted by the valve (6) and the air supplied in the room is the same as leaving the evaporator coil (3), cold and dried.

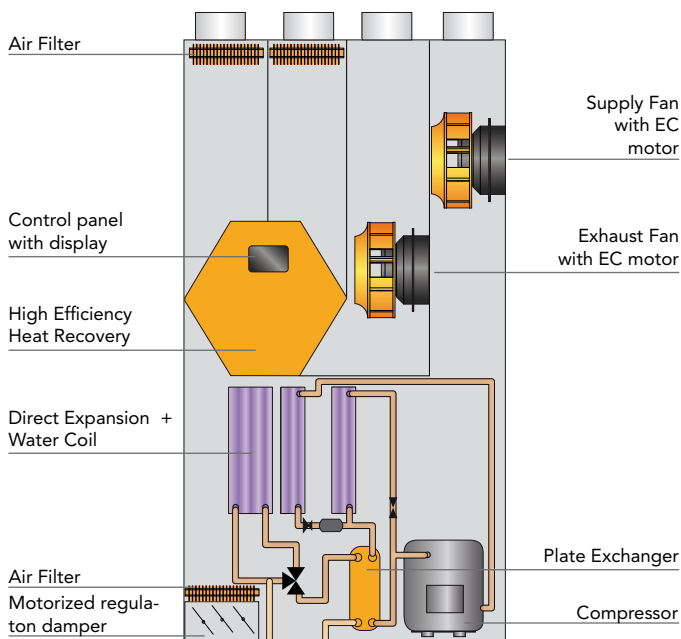

## AERAULIC CIRCUIT FUNCTIONING PRINCIPLE

FHE units can operate with a flow rate of outdoor air from 80 to 130 m<sup>3</sup>/h, to ensure sufficient supply air changes in the room having a variable volume by 430 m<sup>3</sup> (0,3 vol/h) in compliance with regional and national regulations. The air flow rate of discharge can vary from 80 to 130 m<sup>3</sup>/h in the winter mode, and is fixed to 260 m<sup>3</sup>/h in summer mode.

The cross-flow heat exchanger of high efficiency is designed to ensure a recovery rating of 90% in terms of air temperature -5°C and air temperature 20°C. The stale air is expelled from the environment by the fan (1), while the outside air is sucked through the fan (2).

The proper balance of air flows is ensured by the damper (3) that handles both the balance of flows of air and the air flow recirculation summer.

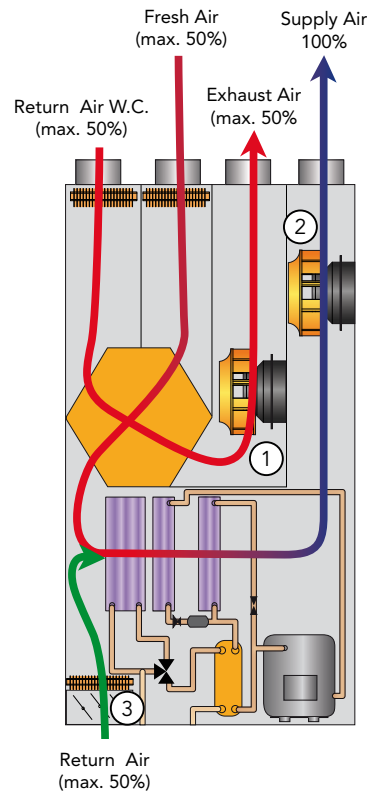

### SUMMER OPERATION (COMPRESSOR ON)

Whit this selected mode, the unit renews the ambient air with the outside through the heat exchanger for high efficiency, air flow is increased so as to allow operation of refrigerant circuit; for this purpose the recycling damper will be open, the supply fan is operated at the maximum capacity and the unit works with external air and partial recirculation.

The possible functions in this configuration are

- **Renewal + Air Dryers neutral:** The condensing unit partially in air and partially in the water through the condenser plate, obtaining dry air and thermally neutral.
- **Renewal + Dehumidification with cooling:** The unit operates with 100% of the condensation water, obtaining dry and cooled air.

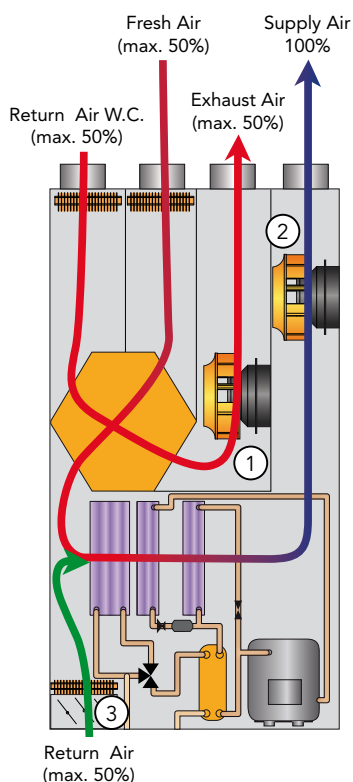

### WINTER OPERATION AND MIDDLE SEASON (COMPRESSOR OFF)

Whit this selected mode, the unit renews the ambient air with the outside through the heat exchanger of high efficiency. The air flow is reduced to the value required by the standard (0,3 ÷ 0,5 Vol/h), the recirculation damper is closed and the unit operates with 100% fresh air.

The possible functions in this configuration are:

- **Renewal with heated air:** The compressor is switched off, the battery can be supplied with hot water from radiant system. (even due to the high efficiency of the heat exchanger, is able to obtain a supply air temperature 17°C, without using hot water and ambient air temperature of -5°C), and behaves like a normal air handling with recovery.

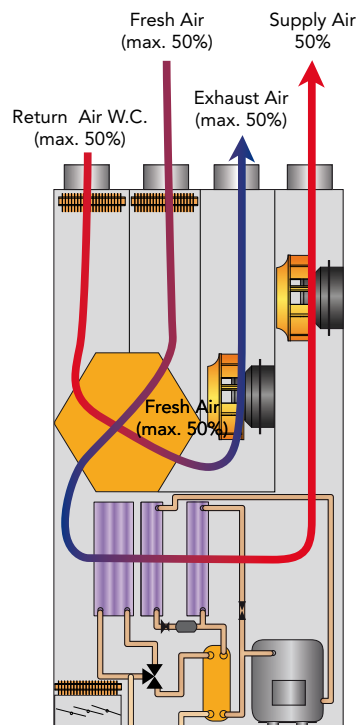



Microprocessor control		●
User flow switch		●
Modulating 3-way valve		●
Supply & Return EC fans		●
G4 air filter		●
Adjustable Trimmers		●
High Efficiency Heat Recovery		●
Humidity and Temperature electronic probe sensor	RGDD	●
Remote control Panel	PCRL	○
Serial interface card RS485	INSE	○

● Standard, ○ Optional, – Not available.

### SUMMER AIR TREATMENT

Recovery	●
Mix flow	●
Pre-Cooling	●
Evaporator	●
Condenser (if active)	●

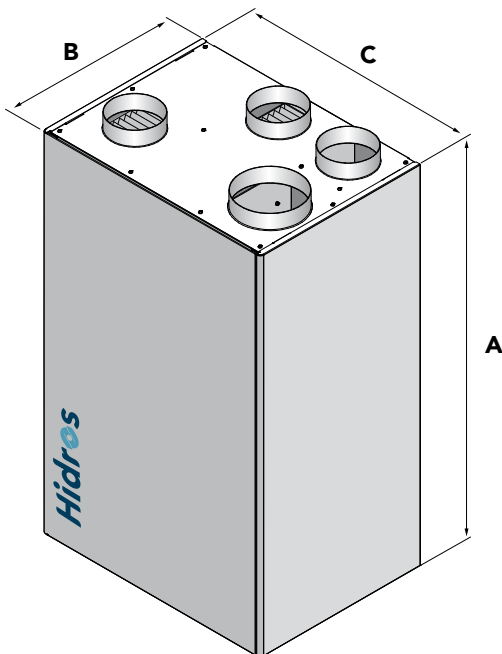
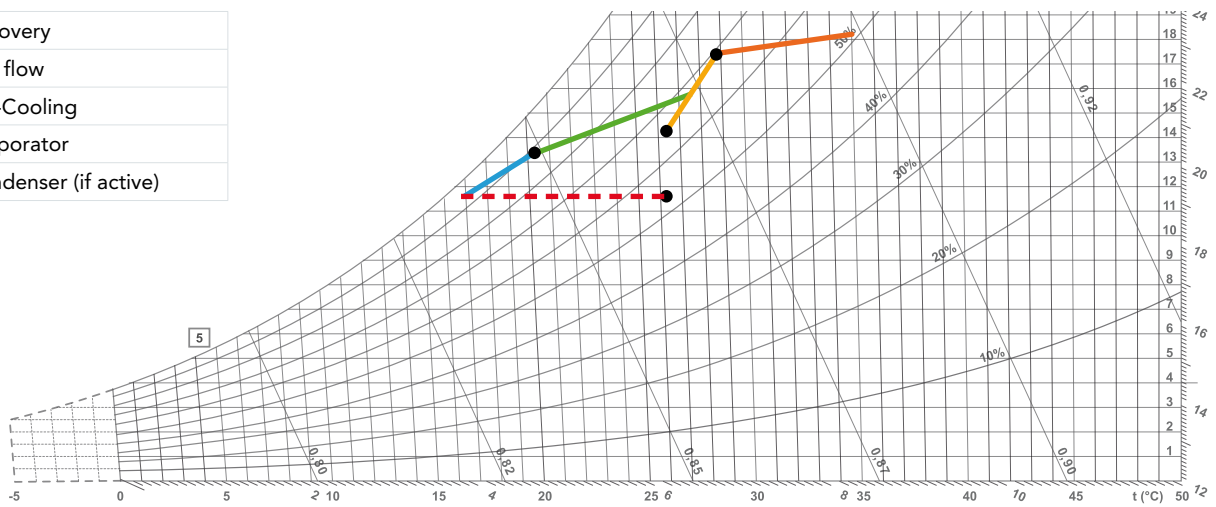

Mod.	A (mm)	B (mm)	C (mm)	kg
26	1125	440	600	90

# HBA

## INDUSTRIAL DEHUMIDIFIERS

Dehumidifying capacity from 50 l/24h to 200 l/24h  
Air flow from 500 m<sup>3</sup>/h to 1650 m<sup>3</sup>/h

R410A



**HBA (A)**



**HBA (P)**

HBA dehumidifiers series are high-performances units especially designed for industrial or commercial purposes where humidity level should be controlled or water vapor condensation should be prevented. These units are particularly indicated for archives, ironing rooms, bookstores, cheese factories, underground rooms, cellars and industrial sites where high humidity level is present. This series comprises 5 models which cover a capacity range from 50 to 200 l/24h. HBA units are designed for easy maintenance and service, each part being readily accessible and, when required, easily replaceable thus reducing service and maintenance costs.

HBA units are designed for easy maintenance and service, each part being readily accessible and, when required, easily replaceable thus reducing service and maintenance costs.

The units are supplied with a solenoid valves set for the hot gas injection used to defrost the evaporator in case of severe working conditions.

Temperature and humidity probes are accessories supplied on request.

### VERSIONS

- A** Version with cabinet
- P** Ductable units.

## TECHNICAL DATA

HBA/A-P		50	75	100	150	200
Moisture removed at 30°C - 80%	l/24h	58,4	80,2	108,6	157,1	210,8
Moisture removed at 30°C - 60%	l/24h	41,1	57,6	77,4	109,5	149,7
Moisture removed at 27°C - 60%	l/24h	35,6	50,6	69,2	97,1	132,3
Moisture removed at 20°C - 60%	l/24h	25,3	36,2	49,4	69,7	95,0
Moisture removed at 10°C - 70%	l/24h	17,3	26,6	33,7	44,3	60,9
Nominal input power <sup>(1)</sup>	kW	0,6	1,2	1,5	2,0	2,5
Maximum input power	kW	1,1	1,9	2,0	2,6	3,3
Maximum input current	A	5,1	7,9	9,2	11,8	15,5
Peak current	A	19	25	37,6	40,4	63,4
Air Flow	m <sup>3</sup> /h	500	800	1000	1400	1650
Available static pressure	Pa	40	40	40	40	40
Refrigerant		R410A	R410A	R410A	R410A	R410A
Global warming potential (GWP)		2088	2088	2088	2088	2088
Refrigerant charge	kg	0,47	0,60	0,70	1,20	1,20
Equivalent CO2 charge	t	0,98	1,25	1,46	2,51	2,51
Sound power <sup>(2)</sup>	dB(A)	68	71	71	73	75
Sound pressure <sup>(3)</sup>	dB(A)	54	57	57	58	60
Power supply	V/Ph/Hz	230/1/50	230/1/50	230/1/50	230/1/50	230/1/50

Performances are calculated with low fan speed and are referred to the following conditions:  
 (1) Temperature 30°C; Humidity 80%

(2) Sound power level calculated according to ISO EN 3744.

(3) Sound pressure level measured at 1 mt from the unit in free field conditions according to ISO EN 3744.

## OPERATION LIMITS

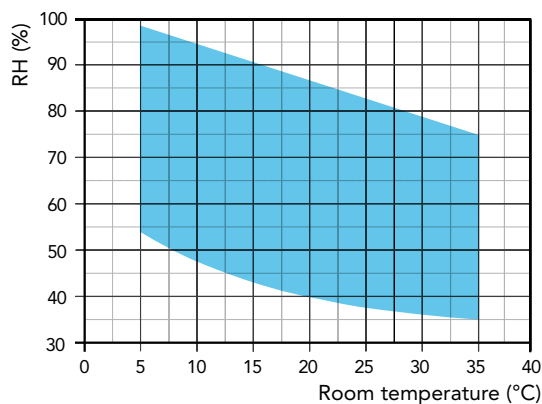

## SYSTEM DIAGRAM

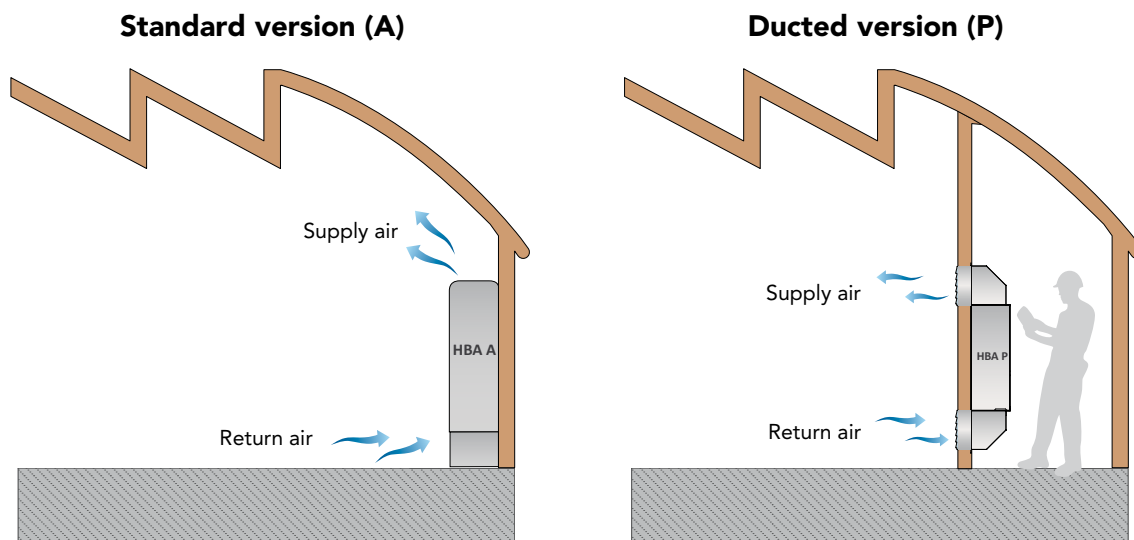

## COMPONENTS

### FRAME

All units are made from hot-galvanised thick sheet metal, painted with polyurethane powder enamel at 180°C to ensure the best resistance against the atmospheric agents and to operate in aggressive environments. The frame is self-supporting with removable panels. The colour of the unit is RAL 9010 both for the base and for the frontal panel.

### REFRIGERANT CIRCUIT

The refrigerant gas used in these units is R410A. The refrigerant circuit is made by using international primary brands components and according to ISO 97/23 concerning welding procedures. The refrigerant circuit includes: sight glass, filter drier, thermal expansion valve with external equalizer, Schrader valves for maintenance and control, pressure safety device (according to PED regulation). All the units are supplied with injection valves kit for hot gas defrost cycle.

### COMPRESSOR

The compressors are rotative type, with thermal overload protection by a klaxon embedded in the motor winding. The compressor is mounted on rubber vibration dampers and it is supplied, standard, with sound-proof cover to reduce noise emission. The inspection is possible through the frontal panel of the unit that allows the maintenance of the compressor.

### CONDENSER AND EVAPORATOR

Condensers and evaporators are made of copper pipes and aluminium fins.

The diameter of the copper pipes is 3/8" and the thickness of the aluminium fins is 0,1 mm. The tubes are mechanically expanded into the aluminium fins to improve the heat exchange factor. The geometry of these heat exchangers guarantees a low air side pressure drop and then the use of low rotation (and low noise emission) fans.

All units are supplied, standard, with a powder coated steel drip tray and all evaporators are supplied with a temperature sensor used as automatic defrost probe.

### FAN

The fans are made of galvanized steel, centrifugal type. It is statically and dynamically balanced and supplied.

The electric motors are directly connected to the fan; they are all at 3 speeds, with integrated thermal protection. The protection class of the motors is IP 54.

### AIR FILTER

It is made of synthetic filtering media, ondulated type, without electro-static charge; they are all removable for differential disposal. Efficiency class coarse 30%, according to UNI EN ISO 16890:2017.

### MICROPROCESSOR

All units are supplied standard with microprocessor controls. The microprocessor controls the following functions: compres-

or timing, automatic defrost cycles, alarms.

An appropriate LCD display shows the operation mode of the unit, set point and alarms.

### ELECTRIC BOX

The electric switch board is made according to electromagnetic compatibility norms CEE 2014/35 and 2014/30. The accessibility to the board is possible after removing the front panel of the unit and the OFF positioning of the main switch. If the unit is endowed of cabinet, after its removal.

### CONTROL AND PROTECTION DEVICES

All units are supplied with the following control and protection devices: antifreeze protection sensor, high pressure switch with manual reset, low pressure switch with automatic reset, high pressure safety valve, compressor thermal overload protection, fans thermal overload protection.

### TEST

All the units are fully assembled and wired at the factory, carefully evacuated and dried after leak tests under pressure and then charged with refrigerant R410A.

They are all fully operational tested before shipment. They all conforms to European Directives and are individually marked with the CE label and provided with Conformity Declaration.

## ACCESSORY DESCRIPTIONS

### HYGR - Remote mechanical hygostat

To be installed on the wall, it is supplied with a regulation knob and working range from 30% to 100% with precision of 3%.

### INSE - Serial interface card RS485

This interface card enables the controller to communicate with other devices using Modbus protocol.

### PCRL - Remote control panel

This panel can be mounted up to 50m (maximum) from the unit and replicates all of the control functions. It is connected using a twin cable of 0.5 mm sq section.

### RGDD - Humidity and Temperature electronic probe sensor

Built-in Electronic temperature and humidity probe.

### KGBH - Louver kit and case for ducted version

Air grille double row adjustable brushed aluminium fins, equipped for wall mounting with subframe.

### LS00 - Low noise version

This version includes the complete acoustic insulation of the unit (compressor + heat exchangers vanes) with compressor jackets and insulating material made with high density media and the interposition of heavy bitumen layer.

**PMBH - Delivery and return plenum 90° (2 pieces)**

To be used for "P" version to direct inlet/outlet air from/to swimming pool and vice versa. Galvanized steel made, coated with polyurethane powder to grant best resistance to weathering and operation in harsh environments.

**ZOCC- Feet**

Metallic galvanized steel feet, painted, used to install the unit on unsuitable walls. The feet can not be used in case the supply and return plenums are present.

**ACCESSORIES**

HBA		50	75	100	150	200
Built-in electronic control with display		●	●	●	●	●
A.C. fans ≤ 40 Pa		●	●	●	●	●
Hot gas defrost		●	●	●	●	●
Thermostatic valve		●	●	●	●	●
Low noise version	LS00	●	●	●	●	●
Main switch		●	●	●	●	●
Remote mechanical hygostat	HYGR	○	○	○	○	○
Humidity and Temperature electronic probe sensor	RGDD	○	○	○	○	○
Remote control Panel	PCRL	○	○	○	○	○
Serial interface card RS485	INSE	○	○	○	○	○
Delivery and return plenum 90° (2 pieces)	PMBH	○	○	○	○	○
Feet	ZOCC	○	○	○	○	○
Louver kit and case for ducted version	KGBH	○	○	○	○	○

● Standard, ○ Optional, – Not available.

**HBA - A**

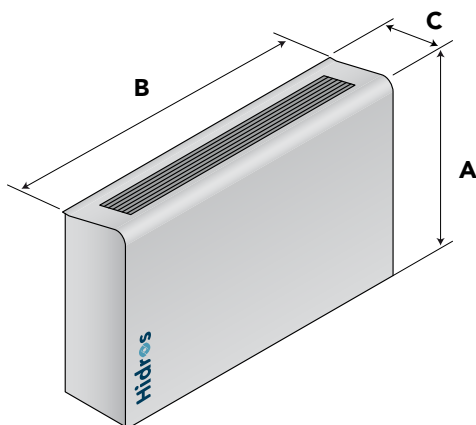

Mod.	A (mm)	B (mm)	C (mm)	kg
<b>50</b>	750	760	260	50
<b>75</b>	750	1060	260	64
<b>100</b>	750	1060	260	68
<b>150</b>	836	1310	310	99
<b>200</b>	836	1310	310	102

**HBA - P**

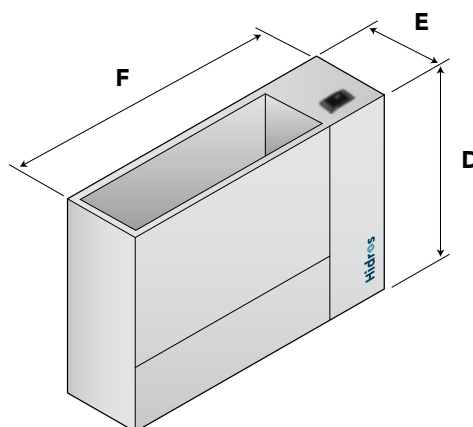

Mod.	D (mm)	E (mm)	F (mm)	kg
<b>50</b>	680	250	706	41
<b>75</b>	680	250	1006	57
<b>100</b>	680	250	1006	61
<b>150</b>	770	300	1255	82
<b>200</b>	770	300	1255	87

# HHΛ

## INDUSTRIAL DEHUMIDIFIERS

Dehumidifying capacity from 50 l/24h to 550 l/24h  
Air flow from 500 m<sup>3</sup>/h to 4200 m<sup>3</sup>/h

---

R410A



---

HHΛ dehumidifiers series are high-performances units especially designed for industrial or commercial purposes where humidity level should be controlled or water vapor condensation should be prevented. These units are particularly indicated for archives, ironing rooms, bookstores, cheese factories, underground rooms, cellars and industrial sites where high humidity level is present. This series comprises 8 models which cover a capacity range from 50 to 550 l/24h. These units are intended to be ceiling installed in a technical room. A centrifugal fan with high available static pressure allows unit connection to ductworks, both for air suction and discharge.

Units from size 50 to 200 are supplied with a solenoid valves set for the hot gas injection used to defrost the evaporator in case of severe working conditions.

Temperature and humidity probes are accessories supplied on request.

### VERSIONS

The series includes 8 models with air flows from 500 to 4200 m<sup>3</sup>/h.

## TECHNICAL DATA

HHA		50	75	100	150	200	300	440	500
Moisture removed at 30°C - 80%	l/24h	55,7	79,6	108,7	169,8	206,4	264,8	439,3	544,0
Moisture removed at 30°C - 60%	l/24h	39,5	56,8	77,5	118,1	146,8	206,1	338,8	389,6
Moisture removed at 27°C - 60%	l/24h	34,9	50,3	69,3	104,7	130,1	186,5	297,5	345,0
Moisture removed at 20°C - 60%	l/24h	24,9	35,9	49,5	75,4	93,2	135,6	222,3	250,6
Nominal input power <sup>(1)</sup>	kW	0,7	1,3	1,7	2,1	2,7	3,8	6,2	7,2
Maximum input power	kW	1,2	2,0	2,1	2,7	3,4	6,4	9,7	11,0
Maximum input current	A	5,9	8,5	10,2	12,6	16,3	10,8	15,8	17,9
Peak current	A	19,9	25,6	38,6	41,2	64,2	51,0	69,8	76,8
Air Flow	m <sup>3</sup> /h	500	800	1000	1400	1650	3500	4200	4200
Available static pressure	Pa	50÷150	50÷150	50÷150	50÷150	50÷150	150÷250	150÷250	150÷250
Refrigerant		R410A	R410A	R410A	R410A	R410A	R410A	R410A	R410A
Global warming potential (GWP)		2088	2088	2088	2088	2088	2088	2088	2088
Refrigerant charge	kg	0,36	0,60	0,60	0,90	1,20	2,5	2,7	3,00
Equivalent CO2 charge	t	0,75	1,25	1,25	1,88	2,20	6,26	6,26	6,26
Sound power <sup>(2)</sup>	dB(A)	71,9	74,0	76,0	81,4	83,4	91,3	92,4	92,4
Sound pressure <sup>(3)</sup>	dB(A)	58,0	60,0	62,0	67,0	69,0	76,0	77,0	77,0
Power supply	V/Ph/Hz	230/1/50	230/1/50	230/1/50	230/1/50	230/1/50	400/3/50	400/3/50	400/3/50

Performances are calculated with low fan speed and are referred to the following conditions:  
 (1) Temperature 30°C; Humidity 80%

(2) Sound power level calculated according to ISO EN 3744.

(3) Sound pressure level measured at 1 mt from the unit in free field conditions according to ISO EN 3744.

### PLANT SCHEME

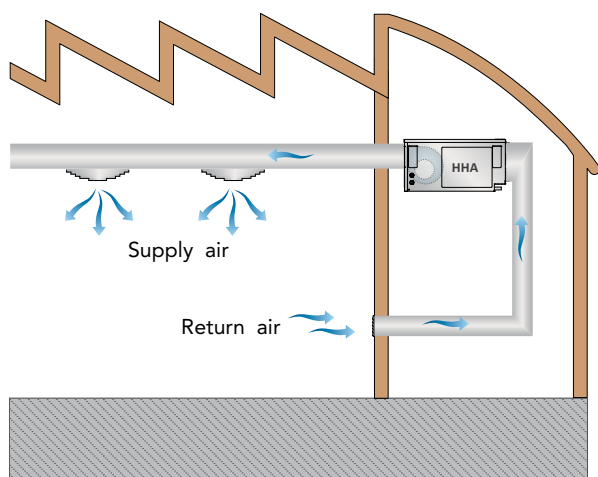

### OPERATION LIMITS

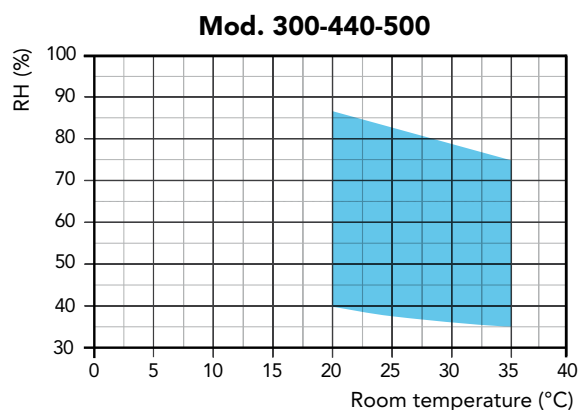
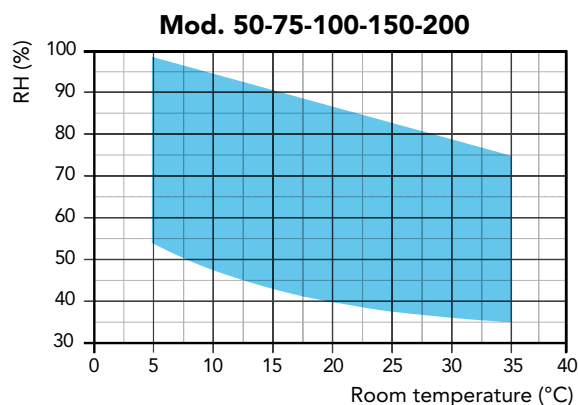

## COMPONENTS

### FRAME

All units are made from hot-galvanised thick sheet metal, painted with polyurethane powder enamel at 180°C to ensure the best resistance against the atmospheric agents and to operate in aggressive environments. The frame is self-supporting with removable panels. The colour of the unit is RAL 9010 both for the base and for the frontal panel.

### REFRIGERANT CIRCUIT

The refrigerant gas used in these units is R410A. The refrigerant circuit is made by using international primary brands components and according to ISO 97/23 concerning welding procedures. The refrigerant circuit includes: sight glass, filter drier, thermal expansion valve with external equalizer, Schrader valves for maintenance and control, pressure safety device (according to PED regulation). Units from size 50 to 200 are supplied with injection valves kit for hot gas defrost cycle.

### COMPRESSOR

The compressors are rotative type, with thermal overload protection by a klixon embedded in the motor winding. The compressor is mounted on rubber vibration dampers and it is supplied, standard, with sound-proof cover to reduce noise emission. The inspection is possible through the frontal panel of the unit that allows the maintenance of the compressor.

### CONDENSER AND EVAPORATOR

Condensers and evaporators are made of copper pipes and aluminium fins.

The diameter of the copper pipes is 3/8" and the thickness of the aluminium fins is 0,1 mm. The tubes are mechanically expanded into the aluminium fins to improve the heat exchange factor. The geometry of these heat exchangers guarantees a low air side pressure drop and then the use of low rotation (and low noise emission) fans.

All units are supplied, standard, with a powder coated steel drip tray and all evaporators are supplied with a temperature sensor used as automatic defrost probe.

### FAN

The fans are made of galvanized steel, centrifugal type. It is statically and dynamically balanced and supplied.

The electric motors are directly connected to the fan; they are all at 3 speeds, with integrated thermal protection. The protection class of the motors is IP 54.

### AIR FILTER

It is made of synthetic filtering media, ondulated type, without electro-static charge; they are all removable for differential disposal, ePM10 50% according to UNI EN ISO 16890:2017.

### MICROPROCESSOR

All units are supplied standard with microprocessor controls. The microprocessor controls the following functions: compressor timing, automatic defrost cycles, alarms.

An appropriate LCD display shows the operation mode of the unit, set point and alarms.

### ELECTRIC BOX

The electric switch board is made according to electromagnetic compatibility norms CEE 2014/35 and 2014/30. The accessibility to the board is possible after removing the front panel of the unit and the OFF positioning of the main switch. If the unit is endowed of cabinet, after its removal.

### CONTROL AND PROTECTION DEVICES

All units are supplied with the following control and protection devices: antifreeze protection sensor, high pressure switch with manual reset, low pressure switch with automatic reset, high pressure safety valve, compressor thermal overload protection, fans thermal overload protection.

### TEST

All the units are fully assembled and wired at the factory, carefully evacuated and dried after leak tests under pressure and then charged with refrigerant R410A.

They are all fully operational tested before shipment. They all conforms to European Directives and are individually marked with the CE label and provided with Conformity Declaration.

## ACCESSORY DESCRIPTIONS

### CANA - Delivery flange for channel connection

Press-folded rectangular flange for connection to the ducts and installed on the fan expulsion mouth

### HYGR - Remote mechanical hygrost

To be installed on the wall, it is supplied with a regulation knob and working range from 30% to 100% with precision of 3%.

### INSE - Serial interface card RS485

This interface card enables the controller to communicate with other devices using Modbus protocol.

### KGBH - Louver kit and case for ducted version

Air grille double row adjustable brushed aluminium fins, equipped for wall mounting with subframe.

### LS00 - Low noise version

This version includes the complete acoustic insulation of the unit (compressor + heat exchangers vanes) with compressor jackets and insulating material made with high density media and the interposition of heavy bitumen layer.

### PCRL - Remote control panel

This panel can be mounted up to 50m (maximum) from the unit and replicates all of the control functions. It is connected using a twin cable of 0.5 mm sq section.

### RGDD - Humidity and Temperature electronic probe sensor

Built-in Electronic temperature and humidity probe.



### V1CE - E.C. Supply fan

The supply fan is a high performance centrifugal type, double inlet forward curved blades, directly coupled to the electric motor. The fan wheel and the scroll are made from hot galvanised thick sheet metal, painted with polyurethane powders, to ensure the best resistance against aggressive environments.

The electric motor is a high efficiency DC brushless type with external rotor, to guarantee an ideal cooling of the windings and the absence of power lost due to pulleys and belt transmission.

The fan is statically and dynamically balanced class 6,3 accord-

ing to ISO1940.

The electric motor has a separate electronic commutator (driver) and a speed modulation 0-10V, integrated PFC, burn out thermal protection (in case of considerable reduction of the power supply), protection degree IP54, serial interface card with mod-bus protocol RTU.

## ACCESSORIES

HH		50	75	100	150	200	300	440	500
A.C. fans ≤ 150 Pa		●	●	●	●	●	●	●	●
Hot gas defrost		●	●	●	●	●	–	–	–
Thermostatic valve		●	●	●	●	●	●	●	●
Low noise version	LS00	●	●	●	●	●	●	●	●
Main switch		●	●	●	●	●	●	●	●
Supply flange	CANA	●	●	●	●	●	●	●	●
Serial interface card RS485	INSE	○	○	○	○	○	○	○	○
Humidity and Temperature electronic probe sensor	RGDD	○	○	○	○	○	○	○	○
Remote mechanical hygostat	HYGR	○	○	○	○	○	○	○	○
Louver kit and case for ducted version	KGBH	○	○	○	○	○	○	○	○
High efficiency E.C. fans ≤ 300 Pa	V1CE	○	○	○	○	○	○	○	○
Remote control Panel	PCRL	○	○	○	○	○	○	○	○

● Standard, ○ Optional, – Not available.

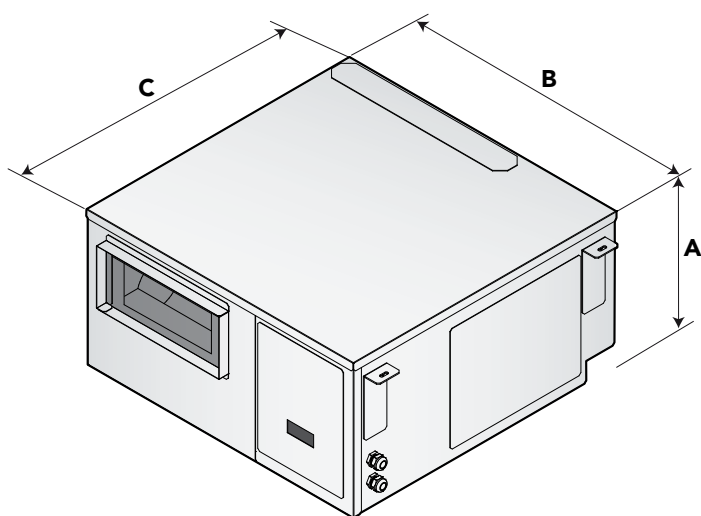

Mod.	A (mm)	B (mm)	C (mm)	kg
50	360	700	710	63
75	460	980	900	95
100	460	980	900	122
150	530	1160	1050	131
200	530	1160	1050	140
300	704	1437	1050	160
440	704	1437	1050	180
500	704	1437	1050	230

# HDA

## INDUSTRIAL DEHUMIDIFIERS

Dehumidifying capacity from 73 l/24h to 200 l/24h  
Air flow from 800 m<sup>3</sup>/h to 1800 m<sup>3</sup>/h

---



---

HDA dehumidifiers series are high-performances units especially designed for industrial or commercial purposes where humidity level should be controlled or water vapor condensation should be prevented. These units are particularly indicated for archives, ironing rooms, bookstores, cheese factories, underground rooms, cellars and industrial sites where high humidity level is present. This series comprises 4 models which cover a capacity range from 73 to 200 l/24h. HDA units are designed for easy maintenance and service, each part being readily accessible and, when required, easily replaceable thus reducing service and maintenance costs. The units are supplied with a solenoid valves set for the hot gas injection used to defrost the evaporator in case of severe working conditions.

Temperature and humidity probes are accessories supplied on request.

### VERSIONS

The series includes 4 models with air flows from 800 to 1800 m<sup>3</sup>/h.

## TECHNICAL DATA

HDA		75	100	150	200
Moisture removed at 30°C - 80%	l/24h	78,5	109,2	133,9	175,9
Moisture removed at 30°C - 60%	l/24h	56,3	77,9	105,9	140,5
Moisture removed at 27°C - 60%	l/24h	49,5	68,8	100,0	128,2
Moisture removed at 20°C - 60%	l/24h	35,4	49,1	73,0	91,2
Moisture removed at 10°C - 70%	l/24h	25,3	35,2	55,2	68,3
Nominal input power <sup>(1)</sup>	kW	1,4	1,8	2,2	2,8
Maximum input power	kW	1,9	2,1	2,9	3,6
Maximum input current	A	7,9	9,6	13,0	16,7
Peak current	A	25,0	38,0	41,6	64,6
Air Flow	m <sup>3</sup> /h	800	1000	1500	1800
Available static pressure	Pa	50÷150	50÷150	50÷150	50÷150
Refrigerant		R410A	R410A	R410A	R410A
Global warming potential (GWP)		2088	2088	2088	2088
Refrigerant charge	kg	0,55	0,55	1,10	1,10
Equivalent CO2 charge	t	1,15	1,15	2,30	2,30
Sound power <sup>(2)</sup>	dB(A)	72,9	74,9	80,9	82,9
Sound pressure <sup>(3)</sup>	dB(A)	59	61	66	68
Power supply	V/Ph/Hz	230/1/50	230/1/50	230/1/50	230/1/50

Performances are calculated with low fan speed and are referred to the following conditions:

(1) Temperature 30°C; Humidity 80%

(2) Sound Power level according to ISO EN 3744 fan with available static pressure 50 Pa.

(3) Sound Pressure level measured at 1 mt from the unit in free field conditions according with ISO EN 3744, fan with available static pressure 50 Pa.

### PLANT SCHEME

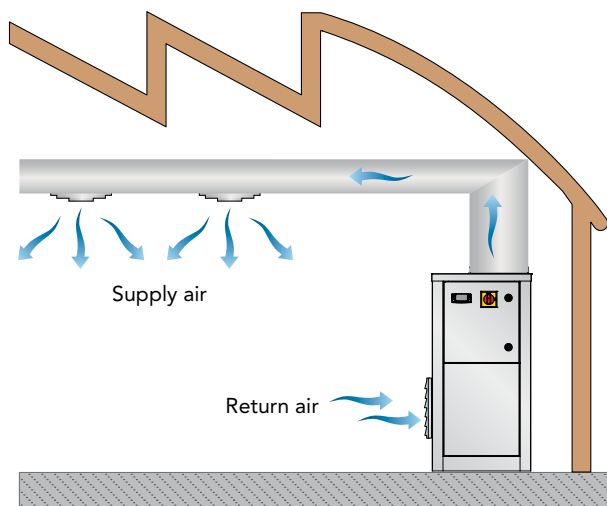

### OPERATION LIMITS

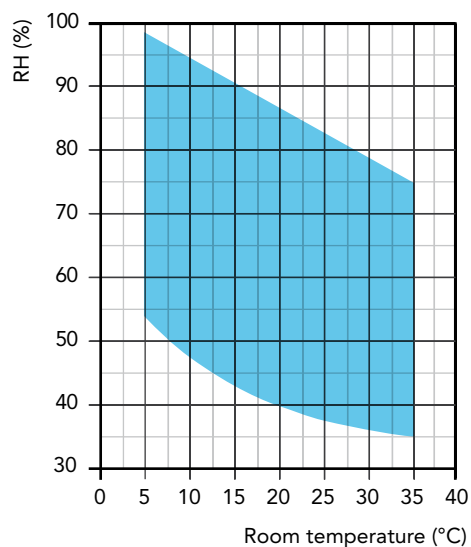

## COMPONENTS

### FRAME

All units are made from hot-galvanised thick sheet metal, painted with polyurethane powder enamel at 180°C to ensure the best resistance against the atmospheric agents. The frame is self-supporting with removable panels. All screws and rivets are in stainless steel. The colour of the units is RAL 9018.

### REFRIGERANT CIRCUIT

The refrigerant gas used in these units is R410A. The refrigerant circuit is made by using international primary brands components and according to ISO 97/23 concerning welding procedures. The refrigerant circuit includes: sight glass, filter drier, thermal expansion valve with external equalizer, Schrader valves form maintenance and control, pressure safety device (according to PED regulation). All the units are supplied with injection valves kit for hot gas defrost cycle.

### COMPRESSOR

The compressors are rotative type, with thermal overload protection by a klixon embedded in the motor winding. The compressor is mounted on rubber vibration dampers and it is supplied, standard, with sound-proof cover to reduce noise emission. The inspection is possible through the frontal panel of the unit that allows the maintenance of the compressor.

### CONDENSER AND EVAPORATOR

Condensers and evaporators are made of copper pipes and aluminium fins.

The diameter of the copper pipes is 3/8" and the thickness of the aluminium fins is 0,1 mm. The tubes are mechanically expanded into the aluminium fins to improve the heat exchange factor. The geometry of these heat exchangers guarantees a low air side pressure drop and then the use of low rotation (and low noise emission) fans.

All units are supplied, standard, with a powder coated steel drip tray and all evaporators are supplied with a temperature sensor used as automatic defrost probe.

### FAN

The fans are made of galvanized steel, centrifugal type. It is statically and dynamically balanced and supplied.

The electric motors are directly connected to the fan; they are all at 3 speeds, with integrated thermal protection. The protection class of the motors is IP 54.

### AIR FILTER

It is made of synthetic filtering media, pleated type, without electro-static charge; they are all removable for differential disposal, ePM10 50% according to UNI EN ISO 16890:2017.

### MICROPROCESSOR

All units are supplied standard with microprocessor controls. The microprocessor controls the following functions: compressor timing, automatic defrost cycles, alarms.

An appropriate LCD display shows the operation mode of the unit, set point and alarms.

### ELECTRIC BOX

The electric switch board is made according to electromagnetic compatibility norms CEE 2014/35 and 2014/30. The accessibility to the board is possible after removing the front panel of the unit and the OFF positioning of the main switch. The following

components are also standard installed: main switch, magnetic-thermal switches (as a protection fans and compressors), control circuit automatic breakers, compressor contactors, fan contactors. The terminal board is supplied with voltage free contacts for remote ON-OFF and general alarm.

### CONTROL AND PROTECTION DEVICES

All units are supplied with the following control and protection devices: antifreeze protection sensor, high pressure switch with manual reset, low pressure switch with automatic reset, high pressure safety valve, compressor thermal overload protection, fans thermal overload protection.

### TEST

All the units are fully assembled and wired at the factory, carefully evacuated and dried after leak tests under pressure and then charged with refrigerant R410A.

They are all fully operational tested before shipment. They all conforms to European Directives and are individually marked with the CE label and provided with Conformity Declaration.

## ACCESSORY DESCRIPTIONS

### CANA - Delivery flange for channel connection

Press-folded rectangular flange for connection to the ducts and installed on the fan expulsion mouth.

### FARC - Air filter with frame for ducted installation

Complete with efficiency class air filter which can be removed by the side and frame for ducted installation.

### HYGR - Remote mechanical hygostat

To be installed on the wall, it is supplied with a regulation knob and working range from 30% to 100% with precision of 3%.

### INOX - Stainless steel frame

It's used to ensure the best resistance against the atmospheric agents and the operation in aggressive environments. The frame is made of stainless steel AISI 304, self-supporting with removable panels to facilitate inspection and maintenance of internal components. All screws and rivets are in stainless steel.

### INSE - Serial interface card RS485

This interface card enables the controller to communicate with other devices using Modbus protocol.

### KAVG - Rubber vibration dampers

To be installed beneath the unit base and the ground to avoid the transmission of vibrations (and the noise) to the building.

### LS00 - Low noise version

This version includes the complete acoustic insulation of the unit (compressor + heat exchangers vanes) with compressor jackets and insulating material made with high density media and the interposition of heavy bitumen layer.

### PCRL - Remote control panel

This panel can be mounted up to 50m (maximum) from the unit and replicates all of the control functions. It is connected using a twin cable of 0.5 mm sq section.

**RGDD - Humidity and Temperature electronic probe sensor**

Built-in Electronic temperature and humidity probe.

**TROL - Floor trolley version**

To facilitate dehumidifier handling where is placed.

**V1CE - E.C. Supply fan**

The supply fan is a high performance centrifugal type, double inlet forward curved blades, directly coupled to the electric motor. The fan wheel and the scroll are made from hot galvanised thick sheet metal, painted with polyurethane powders, to ensure the best resistance against aggressive environments.

The electric motor is a high efficiency DC brushless type with

external rotor, to guarantee an ideal cooling of the windings and the absence of power lost due to pulleys and belt transmission. The fan is statically and dynamically balanced class 6,3 according to ISO1940.

The electric motor has a separate electronic commutator (driver) and a speed modulation 0-10V, integrated PFC, burn out thermal protection (in case of considerable reduction of the power supply), protection degree IP54, serial interface card with mod-bus protocol RTU.

**ACCESSORIES**

HDA		75	100	150	200
A.C. fans ≤ 150 Pa		●	●	●	●
Supply flange	CANA	●	●	●	●
Hot gas defrost		●	●	●	●
Thermostatic valve		●	●	●	●
Low noise version	LS00	●	●	●	●
Main switch		●	●	●	●
Rubber vibration dampers	KAVG	○	○	○	○
Remote mechanical hygostat	HYGR	○	○	○	○
Floor trolley version	TROL	○	○	○	○
Stainless steel frame	INOX	○	○	○	○
Air filter with frame for ducted installation	FARC	○	○	○	○
Humidity and Temperature electronic probe sensor	RGDD	○	○	○	○
Remote control Panel	PCRL	○	○	○	○
High efficiency E.C. fans ≤ 300 Pa	V1CE	○	○	○	○
Serial interface card RS485	INSE	○	○	○	○

● Standard, ○ Optional, – Not available.

**CONFIGURATIONS**

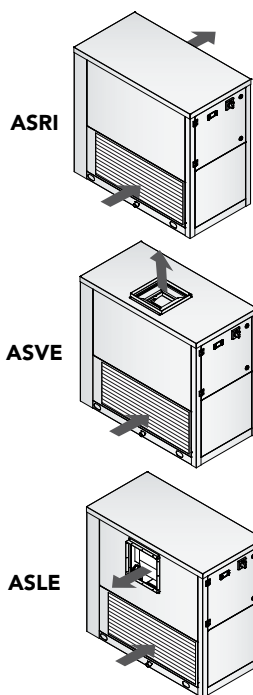

F1

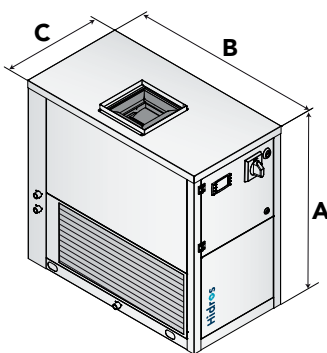

F2

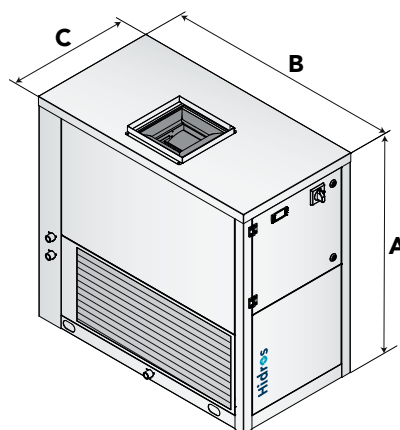

Mod.	Frame	A (mm)	B (mm)	C (mm)	kg
75	F1	800	800	400	85
100	F1	800	800	400	90
150	F2	1000	1060	550	130
200	F2	1000	1060	550	135

# NHA - NHAZ

## INDUSTRIAL DEHUMIDIFIERS WITH TEMPERATURE CONTROL

Dehumidifying capacity from 260 l/24h to 940 l/24h  
Air flow from 3500 m<sup>3</sup>/h to 8500 m<sup>3</sup>/h

R410A



Dehumidifiers are high-performances units especially designed for industrial or commercial purposes where humidity level should be controlled or water vapor condensation should be prevented. These units are particularly indicated for archives, ironing rooms, bookstores, cheese factories, underground rooms, cellars and industrial sites where high humidity level is present. This series comprises 6 models which cover a capacity range from 263 to 940 l/24h. The units are designed for easy maintenance and service, each part being readily accessible and, when required, easily replaceable thus reducing service and maintenance costs.

The NHA units are supplied with a solenoid valves set for the hot gas injection used to defrost the evaporator in case of severe working conditions.

Temperature and humidity probes are accessories supplied on request.

### VERSIONS

- Z** The units in (Z) configuration are supplied complete of external remote condenser who needs to be connected to the dehumidifier through refrigerant lines. The use of remote condenser allows the simultaneous control of temperature and humidity, working in cooling or in dehumidification mode. For a correct operation the units have to be connected to a remote thermostat+ hygrostat.

## TECHNICAL DATA

NHA		275	355	455	555	755	955
Moisture removed at 30°C - 80%	l/24h	254,2	379,8	469,2	591,0	845,9	1028,0
Moisture removed at 30°C - 60%	l/24h	183,7	265,2	341,3	427,9	605,3	766,3
Moisture removed at 27°C - 60%	l/24h	162,0	234,4	305,4	377,1	536,2	682,7
Moisture removed at 20°C - 60%	l/24h	113,2	170,6	222,6	270,4	386,5	508,2
Moisture removed at 10°C - 70%	l/24h	87,9	130,8	164,6	202,2	300,4	388,1
Total cooling cap. (30°C-80% - 35°C ext)	kW	12,93	16,96	19,83	25,57	35,56	43,17
Sensible cooling cap. (30°C-80% - 35°C ext)	kW	4,48	5,91	7,20	8,80	12,45	15,50
Nominal input power at 30°C-80%	kW	4,4	5,5	8,8	9,8	16,0	19,7
Maximum input power	kW	6,4	7,8	10,5	10,6	17,6	20,8
Maximum input current	A	10,8	13,0	17,1	18,3	28,6	35,2
Peak current	A	51,0	66,0	76,0	98,6	103,0	151,0
Air Flow indoor unit	m <sup>3</sup> /h	3500	4200	4200	5500	7000	8500
Air Flow outdoor unit	m <sup>3</sup> /h	7500	7100	6700	15000	14200	21300
Available static pressure	Pa	50	50	50	50	50	50
Refrigerant		R410A	R410A	R410A	R410A	R410A	R410A
Refrigerant charge <sup>(4)</sup>	kg	3,00	2,50	2,50	9,00	8,00	8,00
Global warming potential (GWP)		2088	2088	2088	2088	2088	2088
Equivalent CO <sub>2</sub> charge	t	6,26	5,22	5,22	18,79	16,70	16,70
Sound power <sup>(1)</sup>	dB(A)	84	85	85	87	87	87
Sound pressure <sup>(2)</sup>	dB(A)	69	70	70	70	70	70
Sound pressure <sup>(3)</sup>	dB(A)	53	54	54	55	55	55
Power supply	V/Ph/Hz	400/3+N/50	400/3+N/50	400/3+N/50	400/3+N/50	400/3+N/50	400/3+N/50

Performances are calculated with low fan speed and are referred to the following conditions:

(1) Sound Power level according to ISO EN 3744 fan with available static pressure 50 Pa.

(2) Sound pressure level measured at 1 mt from the unit in free field conditions according to ISO EN 3744. fan with available static pressure 50 Pa.

(3) Sound pressure level measured at 10 mt from the unit in free field conditions according to ISO EN 3744. fan with available static pressure 50 Pa.

(4) Without refrigerant lines content (NHAZ).

### PLANT SCHEME

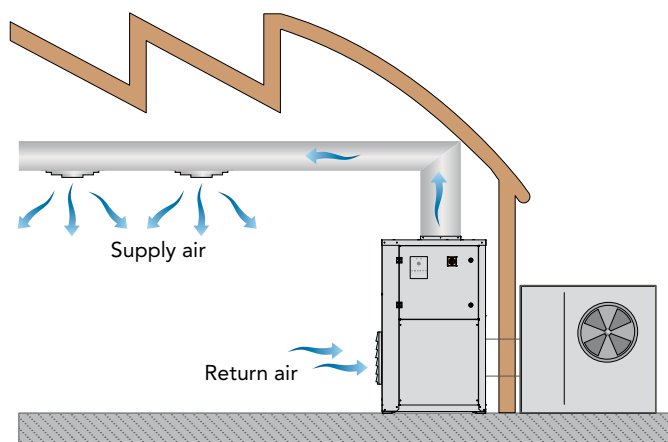

### OPERATION LIMITS

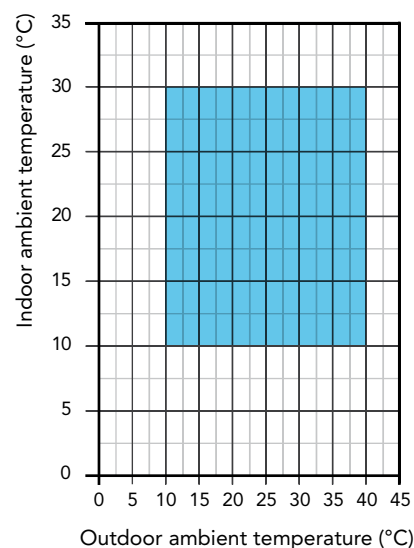
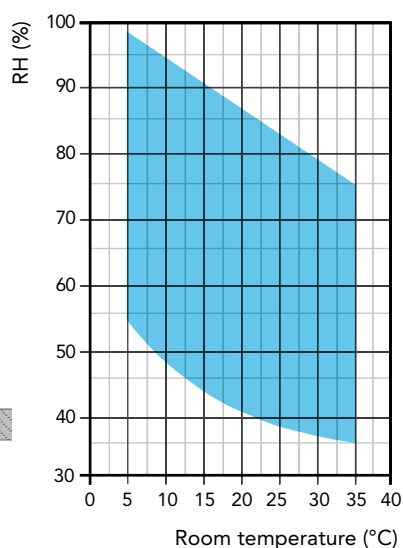

## COMPONENTS

### FRAME

All units are made from hot-galvanised thick sheet metal, painted with polyurethane powder enamel at 180°C to ensure the best resistance against the atmospheric agents. The frame is self-supporting with removable panels. All screws and rivets are in stainless steel. The colour of the units is RAL 9018.

### REFRIGERANT CIRCUIT

The refrigerant gas used in these units is R410A. The refrigerant circuit is made by using international primary brands components and according to ISO 97/23 concerning welding procedures. The refrigerant circuit includes: sight glass, filter drier, thermal expansion valve with external equalizer, Schrader valves form maintenance and control, pressure safety device (according to PED regulation). All the units are supplied with injection valves kit for hot gas defrost cycle.

### COMPRESSORS

The compressors are rotative type, with thermal overload protection by a klixon embedded in the motor winding. The compressor is mounted on rubber vibration dampers and it is supplied, on request, with sound-proof cover (optional) to reduce noise emission. The inspection is possible through the frontal panel of the unit that allows the maintenance of the compressor.

### CONDENSER AND EVAPORATOR

Condensers and evaporators are made of copper pipes and aluminium fins.

The diameter of the copper pipes is 3/8" and the thickness of the aluminium fins is 0,1 mm. The tubes are mechanically expanded into the aluminium fins to improve the heat exchange factor. The geometry of these heat exchangers guarantees a low air side pressure drop and then the use of low rotation (and low noise emission) fans. All units are supplied, standard, with a stainless steel drip tray and all evaporators are supplied with a temperature sensor used as automatic defrost probe.

### SUPPLY FAN

The fans are made of galvanized steel, centrifugal type. It is statically and dynamically balanced and supplied. The electric motors are directly connected to the fan; they are all at 2 speeds, with integrated thermal protection. The protection class of the motors is IP 54.

### AIR FILTER

It is made of synthetic filtering media, undulated type, without electro-static charge; they are all removable for differential disposal, ePM10 50% according to UNI EN ISO 16890:2017.

### MICROPROCESSORS

All units are supplied standard with microprocessor controls. The microprocessor controls the following functions: compressor timing, automatic defrost cycles, alarms. An appropriate LCD display shows the operation mode of the unit, set point and alarms.

### ELECTRIC ENCLOSURE

The electric switch board is made according to electromagnetic compatibility norms CEE 2014/35 and 2014/30. The accessibility to the board is possible after removing the front panel of the unit and the OFF positioning of the main switch. The following components are also standard installed: main switch, magnetic

thermal switches (as a protection fans and compressors), control circuit automatic breakers, compressor contactors, fan contactors. The terminal board is supplied with voltage free contacts for remote ON-OFF and general alarm.

### CONTROL AND PROTECTION DEVICES

All units are supplied with the following control and protection devices: antifreeze protection sensor, high pressure switch with manual reset, low pressure switch with automatic reset, high pressure safety valve, compressor thermal overload protection, fans thermal overload protection.

### TEST

All the units are fully assembled and wired at the factory, the refrigerant circuit is pressure tested to check for leaks then evacuated and charged with the correct weight of R410a. They are all fully operational tested before shipment. They all conforms to European Directives and are individually marked with the CE label and provided with Conformity Declaration.

## ACCESSORY DESCRIPTIONS

### CANA - Delivery flange for channel connection

Press-folded rectangular flange for connection to the ducts and installed on the fan expulsion mouth

### FARC - Air filter with frame for ducted installation

Complete with high efficiency air filter which can be removed by the side and frame for ducted installation.

### HBSEL- HOEL - Electric heater 9kW/18kW

The electric heater kit is in aluminium and is used to integrate the unit heating capacity. The kit is composed of an on-off double safety thermostat without capacity steps.

### HOWA - Hot water coil

The heat exchanger is made of copper pipes and aluminium fins. The diameter of the copper pipes is 3/8" and the thickness of the aluminium fins is 0,1 mm. The tubes are mechanically expanded into the aluminium fins to improve the heat exchange factor.

### HYGR- Remote mechanical hygostat + thermostat

To be installed on the wall, it is supplied with a regulation knob and working range from 30% to 100% with precision of 3%.

### INOX - Stainless steel frame

It's used to ensure the best resistance against the atmospheric agents and the operation in aggressive environments. The frame is made of stainless steel AISI 304, self-supporting with removable panels to facilitate inspection and maintenance of internal components. All screws and rivets are in stainless steel.

### KAVG - Rubber vibration dampers

To be installed beneath the unit base and the ground to avoid the transmission of vibrations (and the noise) to the building.

### KIWA - 3 Way on/off valve

It is used to control the waterflow in the coil. The valve is directly controlled from the unit microprocessor.



### LSMC - Compressor soundproofing

Compressor jackets with high density insulation material.

### SIMC - Wired industrial plug

Appropriately sized with a 2 meter long cable.

### TROL - Floor trolley version

To facilitate dehumidifier handling where is placed.

### V1CE - E.C. Supply fan

The supply fan is a high performance centrifugal type, double inlet forward curved blades, directly coupled to the electric motor. The fan wheel and the scroll are made from hot galvanised thick sheet metal, painted with polyurethane powders, to ensure the best resistance against aggressive environments. The electric motor is a high efficiency DC brushless type with external

rotor, to guarantee an ideal cooling of the windings and the absence of power lost due to pulleys and belt transmission. The fan is statically and dynamically balanced class 6,3 according to ISO1940. The electric motor has a separate electronic commutator (driver) and a speed modulation 0-10V, integrated PFC, burn out thermal protection (in case of considerable reduction of the power supply), protection degree IP54, serial interface card with modbus protocol RTU.

## ACCESSORIES

NHA - NHA Z		275	355	455	555	755	955
Hot gas defrost		●	●	●	●	●	●
Main switch		●	●	●	●	●	●
Supply flange	CANA	○	○	○	○	○	○
Air filter with frame for ducted installation	FARC	○	○	○	○	○	○
A.C. fan with available static pressure up to 150 Pa	HAPS	○	○	○	○	○	○
Electric heater kit 18kW	HBSEL	–	–	–	○	○	○
Electric heater kit 9 kW	HOEL	○	○	○	○	○	○
Hot water coil	HOWA *	○	○	○	○	○	○
Remote mechanical hygostat	HYGR	○	○	○	○	○	○
Stainless steel frame	INOX	○	○	○	○	○	○
Rubber vibration dampers	KAVG	○	○	○	○	○	○
3 Way on/off valve	KIWA	○	○	○	○	○	○
Compressor soundproofing	LSMC	○	○	○	○	○	○
Wired industrial plug	SIMC	○	○	○	○	○	○
Floor trolley version	TROL	○	○	○	○	○	○
High efficiency E.C. fans ≤ 300 Pa	V1CE	○	○	○	○	○	○

\* For NHAZ units it can only be activated in winter and in heating mode.

● Standard, ○ Optional, – Not available.

## CONFIGURATIONS

### ASVE

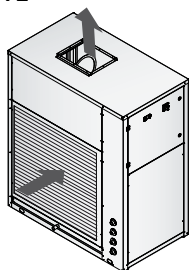

### ASLE

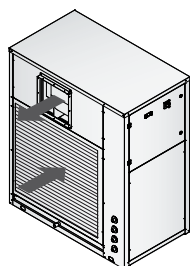

## INDOOR UNIT

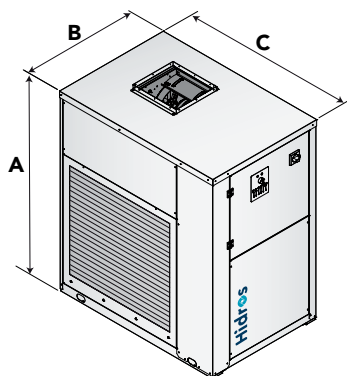

## OUTDOOR UNIT

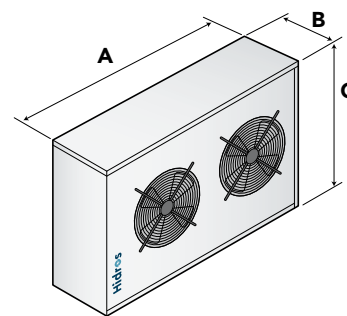

Mod.	Frame	A (mm)	B (mm)	C (mm)	kg
275	F3	1261	758	1118	204
355	F3	1261	758	1118	208
455	F3	1261	758	1118	212
555	F4	1753	858	1519	412
755	F4	1753	858	1519	420
955	F4	1753	858	1519	427

Mod.	A (mm)	B (mm)	C (mm)	kg
275	1582	480	510	44
355	1582	480	510	46
455	1206	570	830	67
555	1206	570	830	71
755	2980	480	510	88
955	2203	570	830	112

# HMA

## INDUSTRIAL DEHUMIDIFIERS

Dehumidifying capacity from 260 l/24h to 940 l/24h  
Air flow from 3500 m<sup>3</sup>/h to 8500 m<sup>3</sup>/h

---

R410A



HMA dehumidifiers series are high-performances units especially designed for industrial or commercial purposes where humidity level should be controlled or water vapor condensation should be prevented. These units are particularly indicated for archives, ironing rooms, bookstores, cheese factories, underground rooms, cellars and industrial sites where high humidity level is present. This series comprises 6 models which cover a capacity range from 263 to 940 l/24h. HMA units are designed for easy maintenance and service, in fact, the internal parts are mainly located in a soundproofed technical compartment, easily accessible even if the unit is running.

The units are supplied with a solenoid valves set for the hot gas injection used to defrost the evaporator in case of severe working conditions.

The units are equipped with an advanced microprocessor with preparation for RS485 connection (optional).

Temperature and humidity probes are accessories supplied on request.

### VERSIONS

The series includes 6 models with air flows from 3500 to 8500 m<sup>3</sup>/h.

## TECHNICAL DATA

HMA		270	350	450	550	750	950
Moisture removed at 30°C - 80%	l/24h	254,2	379,8	469,2	590,9	845,9	1028,0
Moisture removed at 30°C - 60%	l/24h	183,7	265,2	341,3	427,9	605,3	766,3
Moisture removed at 27°C - 60%	l/24h	162,0	234,4	305,4	377,1	536,2	682,7
Moisture removed at 20°C - 60%	l/24h	113,2	170,6	222,6	270,5	386,5	508,2
Moisture removed at 10°C - 70%	l/24h	87,9	130,8	164,6	202,2	300,4	388,1
Nominal input power at 30°C - 80%	kW	4,1	5,2	8,1	9,1	14,3	18,1
Maximum input power	kW	6,4	7,8	10,5	10,6	17,6	20,8
Maximum input current	A	10,8	13,0	17,1	18,3	28,6	35,2
Peak current	A	51,0	66,0	76,0	98,6	103,0	151,0
Air Flow	m <sup>3</sup> /h	3500	4200	4200	5500	7000	8500
Available static pressure	Pa	50÷150	50÷150	50÷150	50÷150	50÷150	50÷150
Refrigerant		R410a	R410a	R410a	R410a	R410a	R410a
Global warming potential (GWP)		2088	2088	2088	2088	2088	2088
Refrigerant charge	kg	3,0	2,5	2,5	9,0	8,0	8,0
Equivalent CO2 charge	t	6,26	5,22	5,22	18,79	16,7	16,7
Sound power <sup>(1)</sup>	dB(A)	84	85	85	87	87	87
Sound pressure <sup>(2)</sup>	dB(A)	68	69	69	70	70	70
Power supply	V/Ph/Hz	400/3+N/50	400/3+N/50	400/3+N/50	400/3+N/50	400/3+N/50	400/3+N/50

Performances are calculated with low fan speed and are referred to the following conditions:  
 (1)Sound Power level according to ISO EN 3744 fan with available static pressure 50 Pa.

(2)Sound Pressure level measured at 1 mt from the unit in free field conditions according with ISO EN 3744, fan with available static pressure 50 Pa.

### PLANT SCHEME

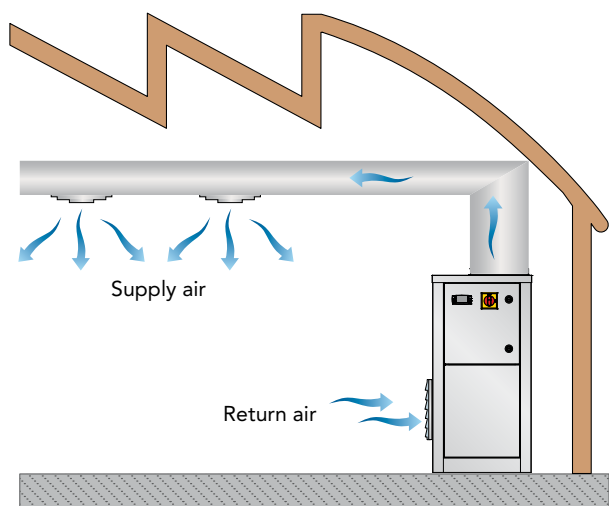

### OPERATION LIMITS

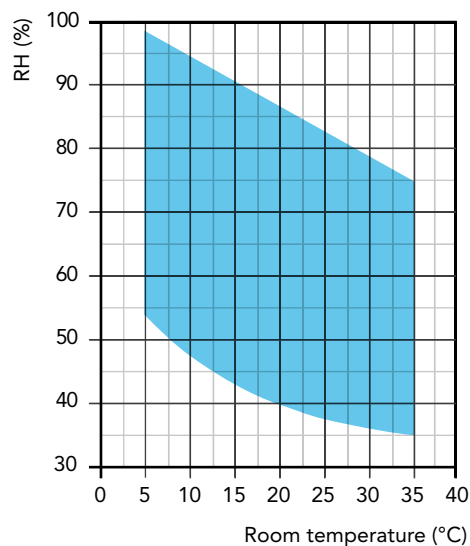

## COMPONENTS

### FRAME

All units are made from hot-galvanised thick sheet metal, painted with polyurethane powder enamel at 180°C to ensure the best resistance against the atmospheric agents. The frame is self-supporting with removable panels. All screws and rivets are in stainless steel. The colour of the units is RAL 9018.

### REFRIGERANT CIRCUIT

The refrigerant gas used in these units is R410A. The refrigerant circuit is made by using international primary brands components and according to ISO 97/23 concerning welding procedures. The refrigerant circuit includes: sight glass, filter drier, thermal expansion valve with external equalizer, Schrader valves for maintenance and control, pressure safety device (according to PED regulation). All the units are supplied with injection valves kit for hot gas defrost cycle.

### COMPRESSOR

The compressors are Scroll type, with thermal overload protection by a klixon embedded in the motor winding. The compressor is mounted on rubber vibration dampers and it is supplied, standard, installed in a dedicated technical compartment to reduce noise emission. The inspection is possible through the frontal panel of the unit that allows the maintenance of the compressor.

### CONDENSER AND EVAPORATOR

Condensers and evaporators are made of copper pipes and aluminium fins.

The diameter of the copper pipes is 3/8" and the thickness of the aluminium fins is 0,1 mm. The tubes are mechanically expanded into the aluminium fins to improve the heat exchange factor. The geometry of these heat exchangers guarantees a low air side pressure drop and then the use of low rotation (and low noise emission) fans.

All units are supplied, standard, with a powder coated steel drip tray and all evaporators are supplied with a temperature sensor used as automatic defrost probe.

### FAN

The fans are made of galvanized steel, centrifugal type. It is statically and dynamically balanced and supplied.

The electric motors are directly connected to the fan; they are all at 2 speeds, with integrated thermal protection. The protection class of the motors is IP 54.

### AIR FILTER

It is made of synthetic filtering media, pleated type, without electro-static charge; they are all removable for differential disposal, ePM10 50% according to UNI EN ISO 16890:2017.

### MICROPROCESSOR

All units are supplied standard with microprocessor controls. The microprocessor controls the following functions: compressor timing, automatic defrost cycles, alarms.

An appropriate LCD display shows the operation mode of the unit, set point and alarms.

### ELECTRIC BOX

The electric switch board is made according to electromagnetic compatibility norms CEE 2014/35 and 2014/30. The accessibility

to the board is possible after removing the front panel of the unit and the OFF positioning of the main switch. The following components are also standard installed: main switch, magnetic-thermal switches (as a protection fans and compressors), control circuit automatic breakers, compressor contactors, fan contactors. The terminal board is supplied with voltage free contacts for remote ON-OFF and general alarm.

### CONTROL AND PROTECTION DEVICES

All units are supplied with the following control and protection devices: antifreeze protection sensor, high pressure switch with manual reset, low pressure switch with automatic reset, high pressure safety valve, compressor thermal overload protection, fans thermal overload protection.

### TEST

All the units are fully assembled and wired at the factory, carefully evacuated and dried after leak tests under pressure and then charged with refrigerant R410A.

They are all fully operational tested before shipment. They all conform to European Directives and are individually marked with the CE label and provided with Conformity Declaration.

## ACCESSORY DESCRIPTIONS

### CANA - Delivery flange for channel connection

Press-folded rectangular flange for connection to the ducts and installed on the fan expulsion mouth.

### FARC - Air filter with frame for ducted installation

Complete with efficiency class air filter which can be removed by the side and frame for ducted installation.

### HYGR - Remote mechanical hygostat

To be installed on the wall, it is supplied with a regulation knob and working range from 30% to 100% with precision of 3%.

### INOX - Stainless steel frame

It's used to ensure the best resistance against the atmospheric agents and the operation in aggressive environments. The frame is made of stainless steel AISI 304, self-supporting with removable panels to facilitate inspection and maintenance of internal components. All screws and rivets are in stainless steel.

### INSE - Serial interface card RS485

This interface card enables the controller to communicate with other devices using Modbus protocol.

### KAVG - Rubber vibration dampers

To be installed beneath the unit base and the ground to avoid the transmission of vibrations (and the noise) to the building.

### LS00 - Low noise version

This version includes the complete acoustic insulation of the unit (compressor + heat exchangers vanes) with compressor jackets and insulating material made with high density media and the interposition of heavy bitumen layer.

### PCRL - Remote control panel

This panel can be mounted up to 50m (maximum) from the unit

and replicates all of the control functions. It is connected using a twin cable of 0.5 mm sq section.

**RGDD - Humidity and Temperature electronic probe sensor**

Built-in Electronic temperature and humidity probe.

**TROL - Floor trolley version**

To facilitate dehumidifier handling where is placed.

**V1CE - E.C. supply fan**

The supply fan is a high performance centrifugal type, double inlet forward curved blades, directly coupled to the electric motor. The fan wheel and the scroll are made from hot galvanised

thick sheet metal, painted with polyurethane powders, to ensure the best resistance against aggressive environments.

The electric motor is a high efficiency DC brushless type with external rotor, to guarantee an ideal cooling of the windings and the absence of power lost due to pulleys and belt transmission. The fan is statically and dynamically balanced class 6,3 according to ISO1940.

The electric motor has a separate electronic commutator (driver) and a speed modulation 0-10V, integrated PFC, burn out thermal protection (in case of considerable reduction of the power supply), protection degree IP54, serial interface card with modbus protocol RTU.

**ACCESSORIES**

HMA		270	350	450	550	750	950
A.C. fans ≤ 150 Pa		●	●	●	●	●	●
Supply flange	CANA	●	●	●	●	●	●
Hot gas defrost		●	●	●	●	●	●
Thermostatic valve		●	●	●	●	●	●
Low noise version	LS00	●	●	●	●	●	●
Main switch		●	●	●	●	●	●
Rubber vibration dampers	KAVG	○	○	○	○	○	○
Remote mechanical hygrostat	HYGR	○	○	○	○	○	○
Floor trolley version	TROL	○	○	○	○	○	○
Stainless steel frame	INOX	○	○	○	○	○	○
Air filter with frame for ducted installation	FARC	○	○	○	○	○	○
Humidity and Temperature electronic probe sensor	RGDD	○	○	○	○	○	○
Remote control Panel	PCRL	○	○	○	○	○	○
High efficiency E.C. fans ≤ 300 Pa	V1CE	○	○	○	○	○	○
Serial interface card RS485	INSE	○	○	○	○	○	○

● Standard, ○ Optional, – Not available.

**CONFIGURATIONS**

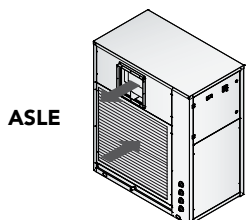
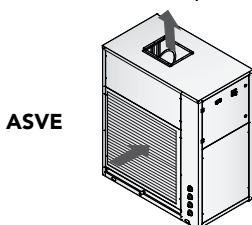
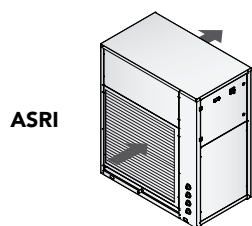

F3

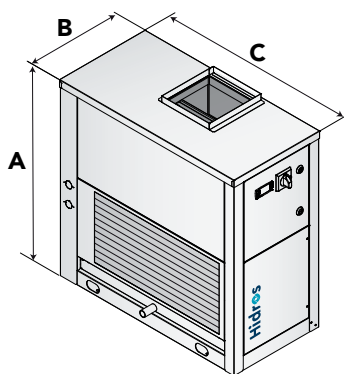

F4

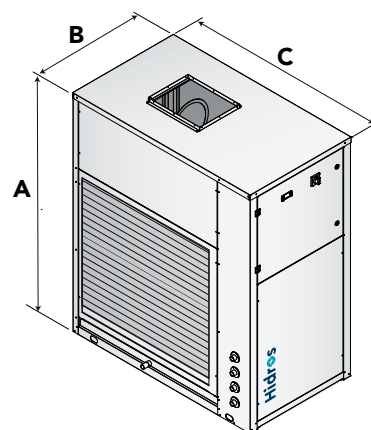

Mod.	Frame	A (mm)	B (mm)	C (mm)	kg
270	F3	1378	704	1154	207
350	F3	1378	704	1154	211
450	F3	1378	704	1154	215
550	F4	1750	854	1504	415
750	F4	1750	854	1504	423
950	F4	1750	854	1504	430

# HMA Z

## INDUSTRIAL DEHUMIDIFIERS WITH TEMPERATURE CONTROL

Dehumidifying capacity from 260 l/24h to 940 l/24h  
Air flow from 3500 m<sup>3</sup>/h to 8500 m<sup>3</sup>/h

R410A



Dehumidifiers are high-performances units especially designed for industrial or commercial purposes where it is necessary the simultaneous control of temperature and humidity or water vapor condensation should be prevented. These units are particularly indicated for archives, ironing rooms, bookstores, cheese factories, underground rooms, cellars and industrial sites where high humidity level is present. This series comprises 6 models which cover a capacity range from 263 to 940 l/24h. The units are designed for easy maintenance and service, in fact, the internal parts are mainly located in a soundproofed technical compartment, easily accessible even if the unit is running. The units are supplied with a solenoid valves set for the hot gas injection used to defrost the evaporator in case of severe working conditions.

Dehumidification mode: the internal condenser is activated; the unit dehumidifies and heats up the room temperature;  
Cooling mode: the remote condenser is activated; the unit dehumidifies and cools down the room temperature.

The units are equipped with an advanced microprocessor with preparation for RS485 connection (optional).

Temperature and humidity probes are accessories supplied on request.

### VERSIONS

**Z** The units in (Z) configuration are supplied complete of external remote condenser who needs to be connected to the dehumidifier through refrigerant lines. The use of remote condenser allows the simultaneous control of temperature and humidity, working in cooling or in dehumidification mode. For a correct operation the units have to be connected to a thermostat+ hygostat.

## TECHNICAL DATA

HMA Z		270	350	450	550	750	950
Moisture removed at 30°C - 80%	l/24h	262,7	375,1	483,7	576,3	853,0	1051,0
Moisture removed at 30°C - 60%	l/24h	188,4	265,2	339,6	412,7	604,5	760,9
Moisture removed at 27°C - 60%	l/24h	162,0	234,4	303,0	363,0	536,2	682,7
Moisture removed at 20°C - 60%	l/24h	115,3	170,4	223,2	271,8	389,7	509,6
Moisture removed at 10°C - 70%	l/24h	93,2	136,3	174,6	206,3	290,1	407,8
Total cooling cap. (30°C-80% - 35°C ext)	kW	11,6	17,2	22,8	25,2	38,8	48,4
Sensible cooling cap. (30°C-80% - 35°C ext)	kW	4,6	6,6	8,4	10,0	14,3	17,9
Nominal input power at 30°C-80%	kW	4,0	5,2	8,3	9,2	14,3	18,2
Maximum input power	kW	6,8	8,2	11,2	11,3	19,0	22,2
Maximum input current	A	12,6	14,8	20,2	21,4	34,8	41,4
Peak current	A	52,8	67,8	79,1	102,0	109,0	157,0
Air Flow indoor unit	m <sup>3</sup> /h	3500	4200	4200	5500	7000	8500
Air Flow outdoor unit	m <sup>3</sup> /h	7500	7100	6700	15000	14200	21300
Available static pressure	Pa	50÷150	50÷150	50÷150	50÷150	50÷150	50÷150
Refrigerant		R410A	R410A	R410A	R410A	R410A	R410A
Global warming potential (GWP)		2088	2088	2088	2088	2088	2088
Refrigerant charge <sup>(4)</sup>	kg	3,0	2,5	2,5	9,0	8,0	8,0
Equivalent CO <sub>2</sub> charge	t	6,26	5,22	5,22	18,79	16,7	16,7
Sound power <sup>(1)</sup>	dB(A)	84	85	85	87	87	87
Sound pressure <sup>(2)</sup>	dB(A)	68	69	69	70	70	70
Sound pressure <sup>(3)</sup>	dB(A)	53	54	54	55	55	55
Power supply	V/Ph/Hz	400/3+N/50	400/3+N/50	400/3+N/50	400/3+N/50	400/3+N/50	400/3+N/50

HMA Z

Performances are calculated with low fan speed and are referred to the following conditions:  
 (1) Sound Power level according to ISO EN 3744 fan with available static pressure 50 Pa.  
 (2) Sound Pressure level measured at 1 mt from the unit in free field conditions according with ISO EN 3744, fan with available static pressure 50 Pa.

(3) Sound pressure level measured at 10 mt from the unit in free field conditions according to ISO EN 3744, fan with available static pressure 50 Pa.  
 (4) Without refrigerant lines content.

### PLANT SCHEME

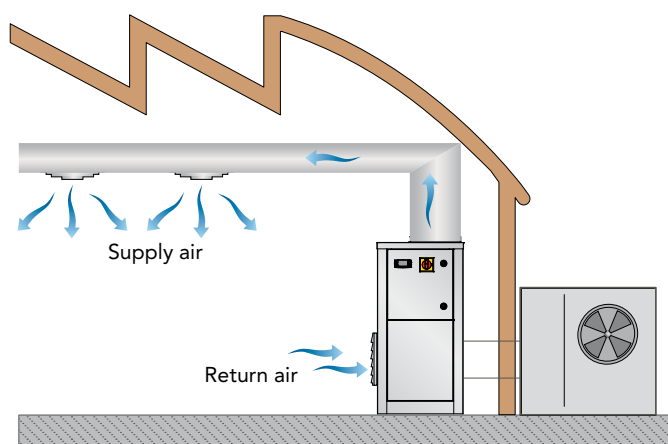

### OPERATION LIMITS

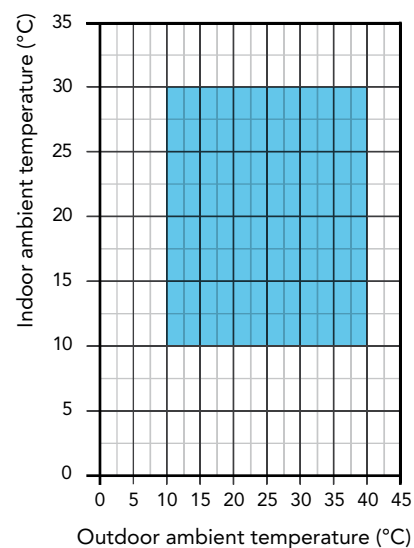
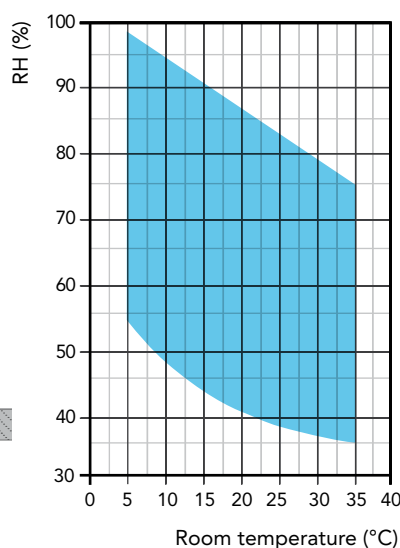

## COMPONENTS

### FRAME

All units are made from hot-galvanised thick sheet metal, painted with polyurethane powder enamel at 180°C to ensure the best resistance against the atmospheric agents. The frame is self-supporting with removable panels. All screws and rivets are in stainless steel. The colour of the units is RAL 9018.

### REFRIGERANT CIRCUIT

The refrigerant gas used in these units is R410A. The refrigerant circuit is made by using international primary brands components and according to ISO 97/23 concerning welding procedures. The refrigerant circuit includes: sight glass, filter drier, thermal expansion valve with external equalizer, Schrader valves form maintenance and control, pressure safety device (according to PED regulation). All the units are supplied with injection valves kit for hot gas defrost cycle.

### COMPRESSOR

The compressors are Scroll type, with thermal overload protection by a klixon embedded in the motor winding. The compressor is mounted on rubber vibration dampers and it is supplied, standard, installed in a dedicated technical compartment to reduce noise emission. The inspection is possible through the frontal panel of the unit that allows the maintenance of the compressor.

### CONDENSER AND EVAPORATOR

Condensers and evaporators are made of copper pipes and aluminium fins.

The diameter of the copper pipes is 3/8" and the thickness of the aluminium fins is 0,1 mm. The tubes are mechanically expanded into the aluminium fins to improve the heat exchange factor. The geometry of these heat exchangers guarantees a low air side pressure drop and then the use of low rotation (and low noise emission) fans.

All units are supplied, standard, with a powder coated steel drip tray and all evaporators are supplied with a temperature sensor used as automatic defrost probe.

### FAN

The fans are made of galvanized steel, centrifugal type. It is statically and dynamically balanced and supplied.

The electric motors are directly connected to the fan; they are all at 3 speeds, with integrated thermal protection. The protection class of the motors is IP 54.

### AIR FILTER

It is made of synthetic filtering media, pleated type, without electro-static charge; they are all removable for differential disposal, ePM10 50% according to UNI EN ISO 16890:2017.

### MICROPROCESSOR

All units are supplied standard with microprocessor controls. The microprocessor controls the following functions: compressor timing, automatic defrost cycles, alarms.

An appropriate LCD display shows the operation mode of the unit, set point and alarms.

### ELECTRIC BOX

The electric switch board is made according to electromagnetic compatibility norms CEE 2014/35 and 2014/30. The accessibility to the board is possible after removing the front panel of the unit and the OFF positioning of the main switch. The following components are also standard installed: main switch, magnetic

thermal switches (as a protection fans and compressors), control circuit automatic breakers, compressor contactors, fan contactors. The terminal board is supplied with voltage free contacts for remote ON-OFF and general alarm.

### EXTERNAL REMOTE CONDENSER

The remote condensers are manufactured from 3/8" copper pipes and 0,1 mm aluminium fins with the tubes being mechanically expanded into the aluminium fins in order to maximise heat transfer. Furthermore, the design guarantees a low air side pressure drop thus enabling the use of low rotation speed (and hence low noise) fans. The fans are direct drive, axial type with aluminium aerofoil blades and are complete with a safety guard. The moisture protection class of the motors is IP 54. The condenser is also fitted with a low ambient condensing pressure control. This device maintains a constant condensing pressure, independent of changes in ambient temperature.

### CONTROL AND PROTECTION DEVICES

All units are supplied with the following control and protection devices: antifreeze protection sensor, high pressure switch with manual reset, low pressure switch with automatic reset, high pressure safety valve, compressor thermal overload protection, fans thermal overload protection.

### TEST

All the units are fully assembled and wired at the factory, carefully evacuated and dried after leak tests under pressure and then charged with refrigerant R410A.

They are all fully operational tested before shipment. They all conform to European Directives and are individually marked with the CE label and provided with Conformity Declaration.

## ACCESSORY DESCRIPTIONS

### CANA - Delivery flange for channel connection

Press-folded rectangular flange for connection to the ducts and installed on the fan expulsion mouth.

### FARC - Air filter with frame for ducted installation

Complete with efficiency class air filter which can be removed by the side and frame for ducted installation.

### INOX - Stainless steel frame

It's used to ensure the best resistance against the atmospheric agents and the operation in aggressive environments. The frame is made of stainless steel AISI 304, self-supporting with removable panels to facilitate inspection and maintenance of internal components. All screws and rivets are in stainless steel.

### INSE - Serial interface card RS485

This interface card enables the controller to communicate with other devices using Modbus protocol.

### KAVG - Rubber vibration dampers

To be installed beneath the unit base and the ground to avoid the transmission of vibrations (and the noise) to the building.

### LS00 - Low noise version

This version includes the complete acoustic insulation of the unit (compressor + heat exchangers vanes) with compressor jackets and insulating material made with high density media and the interposition of heavy bitumen layer.



**PCRL - Remote Control Panel**

This panel can be mounted up to 50m (maximum) from the unit and replicates all of the control functions. It is connected using a twin cable of 0.5 mm sq section.

**RGDD - Humidity and Temperature electronic probe sensor**

Built-in Electronic temperature and humidity probe.

**V1CE - E.C. Supply fan**

The supply fan is a high performance centrifugal type, double inlet forward curved blades, directly coupled to the electric motor. The fan wheel and the scroll are made from hot galvanised thick sheet metal, painted with polyurethane powders, to ensure the best resistance against aggressive environments.

The electric motor is a high efficiency DC brushless type with external rotor, to guarantee an ideal cooling of the windings and the absence of power lost due to pulleys and belt transmission. The fan is statically and dynamically balanced class 6,3 according to ISO1940.

The electric motor has a separate electronic commuter (driver) and a speed modulation 0-10V, integrated PFC, burn out thermal protection (in case of considerable reduction of the power supply), protection degree IP54, serial interface card with mod-bus protocol RTU.

**ACCESSORIES**

HMA Z		270	350	450	550	750	950
A.C. fans ≤ 150 Pa		●	●	●	●	●	●
Supply flange	CANA	●	●	●	●	●	●
Hot gas defrost		●	●	●	●	●	●
Thermostatic valve		●	●	●	●	●	●
Low noise version	LS00	●	●	●	●	●	●
Main switch		●	●	●	●	●	●
Rubber vibration dampers	KAVG	○	○	○	○	○	○
Stainless steel frame	INOX	○	○	○	○	○	○
Air filter with frame for ducted installation	FARC	○	○	○	○	○	○
Humidity and Temperature electronic probe sensor	RGDD	○	○	○	○	○	○
Remote control Panel	PCRL	○	○	○	○	○	○
High efficiency E.C. fans ≤ 300 Pa	V1CE	○	○	○	○	○	○
Serial interface card RS485	INSE	○	○	○	○	○	○

● Standard, ○ Optional, – Not available.

**CONFIGURATIONS**

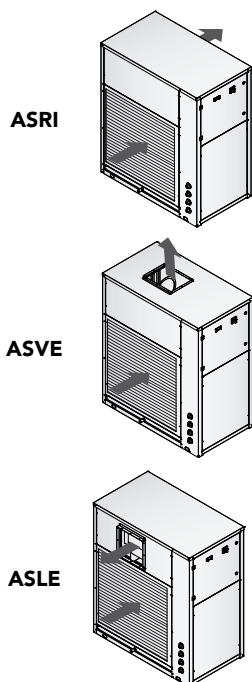

**INDOOR UNIT**

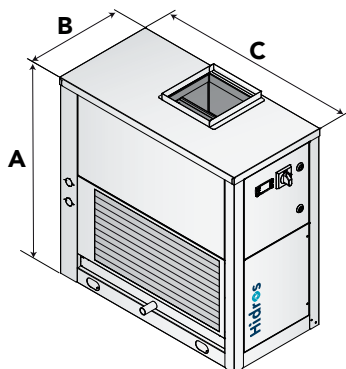

Mod.	Frame	A (mm)	B (mm)	C (mm)	kg
270	F3	1378	704	1154	207
350	F3	1378	704	1154	211
450	F3	1378	704	1154	215
550	F4	1750	854	1504	415
750	F4	1750	854	1504	423
950	F4	1750	854	1504	430

**OUTDOOR UNIT**

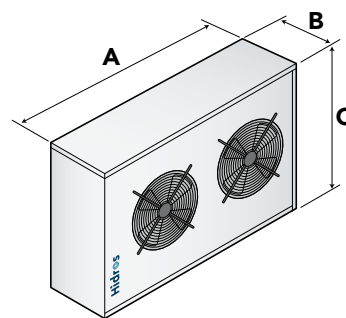

Mod.	A (mm)	B (mm)	C (mm)	kg
270	1582	480	510	44
350	1582	480	510	46
450	1206	570	830	67
550	1206	570	830	71
750	2980	480	510	88
950	2203	570	830	112

# HMA BT

## LOW TEMPERATURE INDUSTRIAL DEHUMIDIFIERS

Dehumidifying capacity from 260 l/24h to 940 l/24h  
Air flow from 3500 m<sup>3</sup>/h to 8500 m<sup>3</sup>/h

R410A



HMA/BT cold room industrial dehumidifiers series are high-performances units especially designed for industrial or commercial purposes where humidity level should be controlled or water vapour condensation should be prevented. These units are particularly indicated for cold rooms, cellars and industrial sites where humidity has to be controlled at low temperature conditions. This series comprises 6 models which cover a capacity range from 263 to 940 l/24h. Units are designed for easy maintenance and service, in fact, the internal parts are mainly located in a soundproofed technical compartment, easily accessible even if the unit is running.

The units are supplied with a specific refrigerant circuit design to operate with a wide range of temperatures, they are also equipped with hot gas injection system (used to defrost the evaporator) and condensate discharge drip tray equipped with antifreeze heater, in case of operation in low ambient temperature conditions.

The units are equipped with an advanced microprocessor with preparation for RS485 connection (optional).

Temperature and humidity probes are accessories supplied on request.

### VERSIONS

The series includes 6 models with air flows from 3500 to 8500 m<sup>3</sup>/h.

## TECHNICAL DATA

HMA BT		270	350	450	550	750	950
Moisture removed at 30°C - 80%	l/24h	254,2	379,8	469,2	590,9	845,9	1028,0
Moisture removed at 30°C - 60%	l/24h	183,7	265,2	341,3	427,9	605,3	766,3
Moisture removed at 27°C - 60%	l/24h	162,0	234,4	305,4	377,1	536,2	682,7
Moisture removed at 20°C - 60%	l/24h	113,2	170,6	222,6	270,5	386,5	508,2
Moisture removed at 10°C - 70%	l/24h	96,0	132,4	175,2	206,2	298,9	391,7
Moisture removed at 5°C - 70%	l/24h	72,5	101,3	132,5	155,5	227,9	326,3
Nominal input power at 30°C - 80%	kW	4,1	5,2	8,1	9,1	14,3	18,1
Maximum input power	kW	6,4	7,8	10,5	10,6	17,6	20,8
Maximum input current	A	10,8	13,0	17,1	18,3	28,6	35,2
Peak current	A	51,0	66,0	76,0	98,6	103,0	151,0
Air Flow	m <sup>3</sup> /h	3500	4200	4200	5500	7000	8500
Available static pressure	Pa	50÷150	50÷150	50÷150	50÷150	50÷150	50÷150
Refrigerant		R410A	R410A	R410A	R410A	R410A	R410A
Global warming potential (GWP)		2088	2088	2088	2088	2088	2088
Refrigerant charge	kg	3,0	2,5	2,5	9,0	8,0	8,0
Equivalent CO <sub>2</sub> charge	t	6,26	5,22	5,22	18,79	16,7	16,7
Sound power <sup>(1)</sup>	dB(A)	84	85	85	87	87	87
Sound pressure <sup>(2)</sup>	dB(A)	68	69	69	70	70	70
Power supply	V/Ph/Hz	400/3+N/50	400/3+N/50	400/3+N/50	400/3+N/50	400/3+N/50	400/3+N/50

Performances are calculated with low fan speed and are referred to the following conditions:  
 (1) Sound Power level according to ISO EN 3744 fan with available static pressure 50 Pa.

(2) Sound Pressure level measured at 1 mt from the unit in free field conditions according with ISO EN 3744, fan with available static pressure 50 Pa.

### PLANT SCHEME

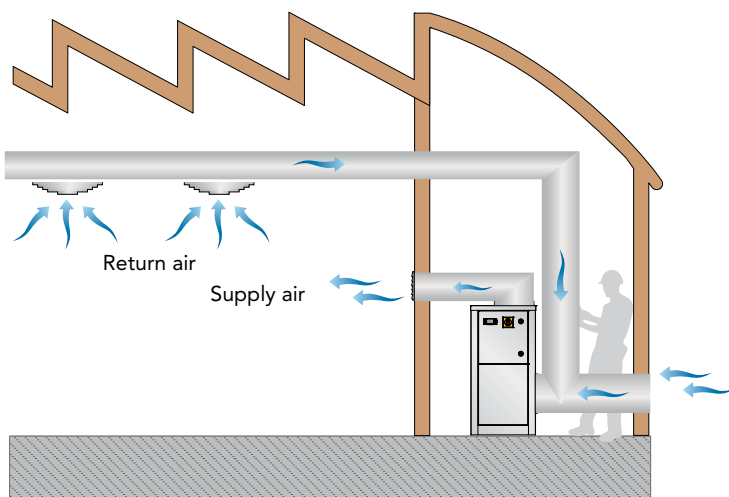

### OPERATION LIMITS

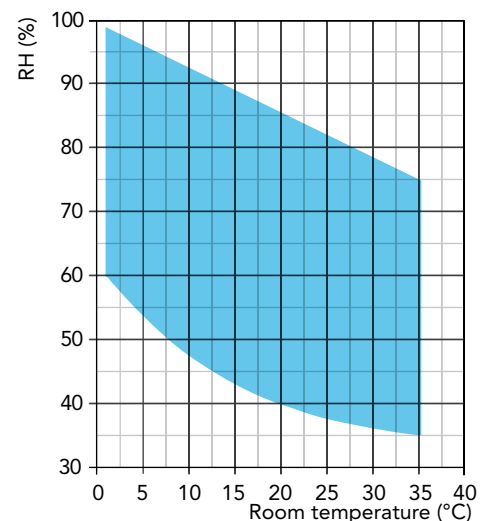

## COMPONENTS

### FRAME

All units are made from hot-galvanised thick sheet metal, painted with polyurethane powder enamel at 180°C to ensure the best resistance against the atmospheric agents. The frame is self-supporting with removable panels. All screws and rivets are in stainless steel. The colour of the units is RAL 9018.

### REFRIGERANT CIRCUIT

The refrigerant gas used in these units is R410A. The refrigerant circuit is made by using international primary brands components and according to ISO 97/23 concerning welding procedures. The refrigerant circuit includes: sight glass, filter drier, thermal expansion valve with external equalizer, Schrader valves form maintenance and control, pressure safety device (according to PED regulation).

The units are supplied with a specific refrigerant circuit design to operate with a wide range of temperatures, they are also equipped with hot gas injection system.

### COMPRESSOR

The compressors are Scroll type, with thermal overload protection by a klixon embedded in the motor winding. The compressor is mounted on rubber vibration dampers and it is supplied, standard, installed in a dedicated technical compartment to reduce noise emission. The inspection is possible through the frontal panel of the unit that allows the maintenance of the compressor.

### CONDENSER AND EVAPORATOR

Condensers and evaporators are made of copper pipes and aluminium fins.

The diameter of the copper pipes is 3/8" and the thickness of the aluminium fins is 0,1 mm. The tubes are mechanically expanded into the aluminium fins to improve the heat exchange factor. The geometry of these heat exchangers guarantees a low air side pressure drop and then the use of low rotation (and low noise emission) fans.

All units are supplied, standard, with a powder coated steel drip tray and all evaporators are supplied with a temperature sensor used as automatic defrost probe.

### FAN

The fans are made of galvanized steel, centrifugal type. It is statically and dynamically balanced and supplied.

The electric motors are directly connected to the fan; they are all at 3 speeds, with integrated thermal protection. The protection class of the motors is IP 54.

### AIR FILTER

It is made of synthetic filtering media, pleated type, without electro-static charge; they are all removable for differential disposal, ePM10 50% according to UNI EN ISO 16890:2017.

### MICROPROCESSOR

All units are supplied standard with microprocessor controls. The microprocessor controls the following functions: compressor timing, automatic defrost cycles, alarms.

An appropriate LCD display shows the operation mode of the unit, set point and alarms.

### ELECTRIC BOX

The electric switch board is made according to electromagnetic compatibility norms CEE 2014/35 and 2014/30. The accessibility to the board is possible after removing the front panel of the unit and the OFF positioning of the main switch. The following

components are also standard installed: main switch, magnetic-thermal switches (as a protection fans and compressors), control circuit automatic breakers, compressor contactors, fan contactors. The terminal board is supplied with voltage free contacts for remote ON-OFF and general alarm.

### CONTROL AND PROTECTION DEVICES

All units are supplied with the following control and protection devices: antifreeze protection sensor, high pressure switch with manual reset, low pressure switch with automatic reset, high pressure safety valve, compressor thermal overload protection, fans thermal overload protection.

### TEST

All the units are fully assembled and wired at the factory, carefully evacuated and dried after leak tests under pressure and then charged with refrigerant R410A.

They are all fully operational tested before shipment. They all conform to European Directives and are individually marked with the CE label and provided with Conformity Declaration.

## ACCESSORY DESCRIPTIONS

### CANA - Delivery flange for channel connection

Press-folded rectangular flange for connection to the ducts and installed on the fan expulsion mouth.

### FARC - Air filter with frame for ducted installation

Complete with efficiency class air filter which can be removed by the side and frame for ducted installation.

### HYGR - Remote mechanical hygostat

To be installed on the wall, it is supplied with a regulation knob and working range from 30% to 100% with precision of 3%.

### INOX - Stainless steel frame

It's used to ensure the best resistance against the atmospheric agents and the operation in aggressive environments. The frame is made of stainless steel AISI 304, self-supporting with removable panels to facilitate inspection and maintenance of internal components. All screws and rivets are in stainless steel.

### INSE - Serial interface card RS485

This interface card enables the controller to communicate with other devices using Modbus protocol.

### KAVG - Rubber vibration dampers

To be installed beneath the unit base and the ground to avoid the transmission of vibrations (and the noise) to the building.

### LS00 - Low noise version

This version includes the complete acoustic insulation of the unit (compressor + heat exchangers vanes) with compressor jackets and insulating material made with high density media and the interposition of heavy bitumen layer.

### PCRL - Remote control panel

This panel can be mounted up to 50m (maximum) from the unit and replicates all of the control functions. It is connected using a twin cable of 0.5 mm sq section.

### RGDD - Humidity and Temperature electronic probe sensor

built-in Electronic temperature and humidity probe.

**TROL - Floor trolley version**

To facilitate dehumidifier handling where is placed.

**V1CE - E.C. Supply fan**

The supply fan is a high performance centrifugal type, double inlet forward curved blades, directly coupled to the electric motor. The fan wheel and the scroll are made from hot galvanised thick sheet metal, painted with polyurethane powders, to ensure the best resistance against aggressive environments.

The electric motor is a high efficiency DC brushless type with external rotor, to guarantee an ideal cooling of the windings and

the absence of power lost due to pulleys and belt transmission. The fan is statically and dynamically balanced class 6,3 according to ISO1940.

The electric motor has a separate electronic commutator (driver) and a speed modulation 0-10V, integrated PFC, burn out thermal protection (in case of considerable reduction of the power supply), protection degree IP54, serial interface card with modbus protocol RTU.

**ACCESSORIES**

HMA BT		270	350	450	550	750	950
A.C. fans ≤ 150 Pa		●	●	●	●	●	●
Supply flange	CANA	●	●	●	●	●	●
Hot gas defrost		●	●	●	●	●	●
Designed for continuous operation in low ambient temperatures		●	●	●	●	●	●
Thermostatic valve		●	●	●	●	●	●
Condensate discharge drip tray with antifreeze heater		●	●	●	●	●	●
Low noise version	LS00	●	●	●	●	●	●
Main switch		●	●	●	●	●	●
Rubber vibration dampers	KAVG	○	○	○	○	○	○
Remote mechanical hygostat	HYGR	○	○	○	○	○	○
Floor trolley version	TROL	○	○	○	○	○	○
Stainless steel frame	INOX	○	○	○	○	○	○
Air filter with frame for ducted installation	FARC	○	○	○	○	○	○
Humidity and Temperature electronic probe sensor	RGDD	○	○	○	○	○	○
Remote control Panel	PCRL	○	○	○	○	○	○
High efficiency E.C. fans ≤ 300 Pa	V1CE	○	○	○	○	○	○
Serial interface card RS485	INSE	○	○	○	○	○	○

● Standard, ○ Optional, – Not available.

**CONFIGURATIONS**

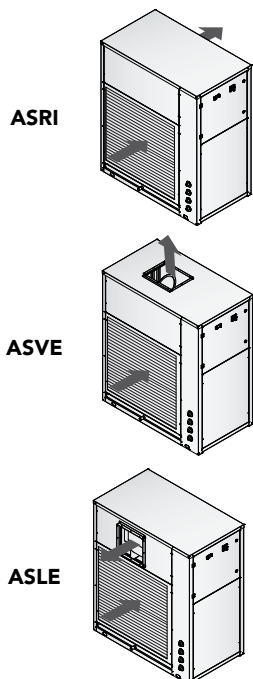

**F3**

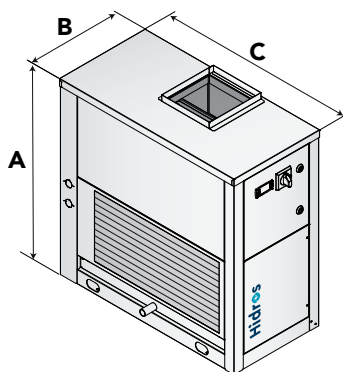

**F4**

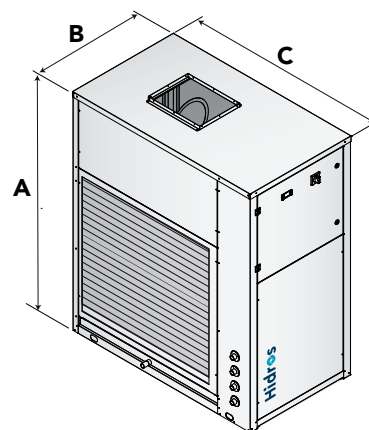

Mod.	Frame	A (mm)	B (mm)	C (mm)	kg
<b>270</b>	F3	1378	704	1154	207
<b>350</b>	F3	1378	704	1154	211
<b>450</b>	F3	1378	704	1154	215
<b>550</b>	F4	1750	854	1504	415
<b>750</b>	F4	1750	854	1504	423
<b>950</b>	F4	1750	854	1504	430

# SBA

## SWIMMING POOL DEHUMIDIFIERS

Dehumidifying capacity from 50 l/24h to 190 l/24h  
Air flow from 500 m<sup>3</sup>/h to 1650 m<sup>3</sup>/h

R410A



**SBA (A)**



**SBA (P)**

Series SBA dehumidifier are expressly designed for use in swimming pools where humidity should be closely controlled in order to guarantee optimal comfort. This series comprises five models which cover a capacity range from 50 to 200 l/24h.

SBA units are designed for easy maintenance and service, each part being readily accessible and, when required, easily replaceable thus reducing service and maintenance costs.

Temperature and humidity probes are accessories supplied on request.

### VERSIONS

- A** Version with cabinet
- P** Ductable units.

# TECHNICAL DATA

SBA/A-P		50	75	100	150	153	200	203
Moisture removed at 30°C - 80%	l/24h	56,0	79,4	108,2	154,9	151,1	209,6	207,0
Moisture removed at 30°C - 60%	l/24h	40,7	58,0	79,1	111,8	112,0	151,5	151,8
Moisture removed at 27°C - 60%	l/24h	35,7	50,8	69,1	97,1	97,1	132,2	132,2
Moisture removed at 20°C - 60%	l/24h	25,2	35,8	48,9	68,8	67,4	93,6	92,5
Nominal input power <sup>(1)</sup>	kW	0,7	1,2	1,6	1,7	1,8	2,5	2,6
Maximum input power <sup>(1)</sup>	kW	1,1	1,8	2,0	2,6	2,9	3,3	3,3
Maximum input power <sup>(2)</sup>	kW	3,4	4,4	5,0	8,7	7,2	9,4	7,7
Supplementary electric heater	kW	3	3	3	6	4,5	6	4,5
Maximum input current <sup>(1)</sup>	A	5,1	7,5	9,2	11,8	6,1	15,5	6,8
Maximum input current <sup>(2)</sup>		14,9	19,8	20,8	38,0	25,3	41,7	26,7
Peak current <sup>(1)</sup>	A	19,0	24,6	37,6	40,4	28,4	63,4	31,4
Peak current <sup>(2)</sup>		30	38	51	71	49	90	64
Hot water coil <sup>(3)</sup>	kW	3,5	7,0	7,0	11,5	11,5	11,8	11,8
Air Flow	m <sup>3</sup> /h	500	800	1000	1400	1400	1650	1650
Available static pressure	Pa	40	40	40	40	40	40	40
Refrigerant		R410A	R410A	R410A	R410A	R410A	R410A	R410A
Global warming potential (GWP)		2088	2088	2088	2088	2088	2088	2088
Refrigerant charge	kg	0,47	0,60	0,70	1,20	1,20	1,20	1,20
Equivalent CO2 charge	t	0,98	1,25	1,46	2,51	2,51	2,51	2,51
Sound power <sup>(4)</sup>	dB(A)	68	71	71	73	73	75	75
Sound pressure <sup>(5)</sup>	dB(A)	54	57	57	58	58	60	60
Power supply	V/Ph/Hz	230/1/50	230/1/50	230/1/50	230/1/50	400/3+N/50	230/1/50	400/3+N/50

SBA

Performances are calculated with low fan speed and are referred to the following conditions:

- (1) Temperature 30°C; Humidity 80%.
- (2) Without electric heater.

(3) Room temperature 30°C; water temperature 80/70°C, at compressor OFF

(4) Sound power level calculated according to ISO EN 3744.

(5) Sound pressure level measured at 1 mt from the unit in free field conditions according to ISO EN 3744.

## OPERATION LIMITS

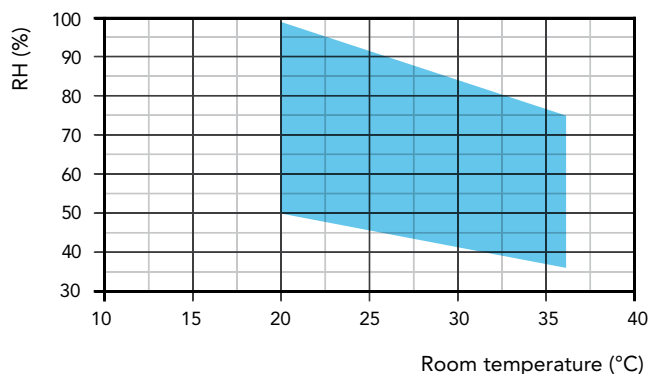

### Standard version (A)

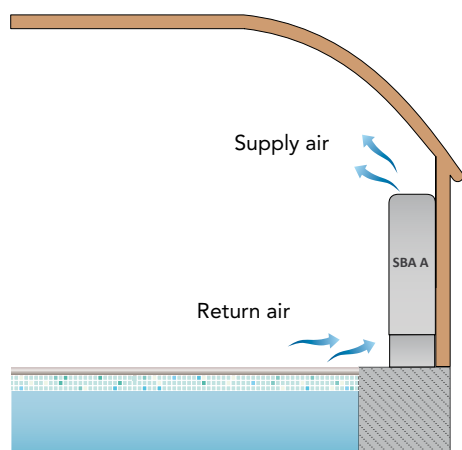

### Ducted version (P)

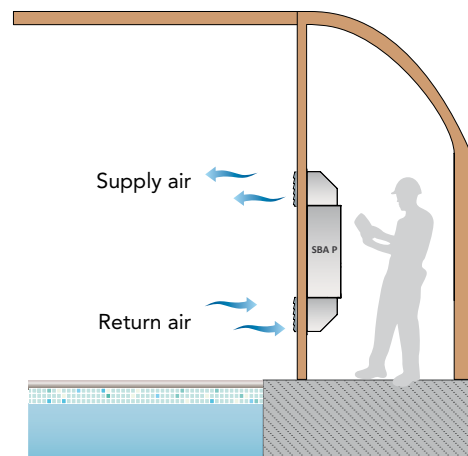

## COMPONENTS

### FRAME

All SBA units are made from hot-galvanised thick sheet metal, painted with polyurethane powder enamel at 180°C to ensure the best resistance against the atmospheric agents and to operate in aggressive environments. The frame is self-supporting with removable panels. A PVC drip tray is installed on all units. The colour of the unit is RAL 9010 both for the base and for the frontal panel.

### REFRIGERANT CIRCUIT

The refrigerant circuit is made by using international primary brands components and according to ISO 97/23 concerning welding procedures. The refrigerant gas used in these units is R410A. The refrigerant circuit includes: capillary tube, Schrader valves for maintenance and control, pressure safety device (according to PED regulation).

### COMPRESSOR

The compressors are rotative type, with thermal overload protection by a klixon embedded in the motor winding. The compressor is mounted on rubber vibration dampers and it is supplied, standard, with sound-proof cover to reduce noise emission. The inspection is possible through the frontal panel of the unit that allows the maintenance of the compressor.

### CONDENSER AND EVAPORATOR

Condensers and evaporators are made of copper pipes and aluminium fins.

All evaporators are painted with epoxy powders to prevent corrosion problem due to their use in aggressive environments. The diameter of the copper pipes is 3/8" and the thickness of the aluminium fins is 0,15 mm. The tubes are mechanically expanded into the aluminium fins to improve the heat exchange factor. The geometry of these heat exchangers guarantees a low air side pressure drop and then the use of low rotation (and low noise emission) fans. All units are supplied, standard, with a PVC drip tray and all evaporators are supplied with a temperature sensor used as automatic defrost probe.

### FAN

The fans are made of galvanized steel, centrifugal type. It is statically and dynamically balanced and supplied.

The electric motors are directly connected to the fan; they are all at 3 speeds, with integrated thermal protection. The protection class of the motors is IP 54.

### AIR FILTER

It is made of synthetic filtering media, ondulated type, without electro-static charge; they are all removable for differential disposal. Efficiency class coarse 30%, according to UNI EN ISO 16890:2017.

### MICROPROCESSOR

All units are supplied standard with microprocessor controls. The microprocessor controls the following functions: compressor timing, automatic defrost cycles, alarms.

An appropriate LCD display shows the operation mode of the unit, set point and alarms.

### ELECTRIC BOX

The electric switch board is made according to electromagnetic compatibility norms CEE 2014/35 and 2014/30. The accessibility to the board is possible after removing the front panel of the unit and the OFF positioning of the main switch. If the unit is endowed of cabinet, after its removal.

### CONTROL AND PROTECTION DEVICES

All units are supplied with the following control and protection devices: defrost thermostat, which signals to the microprocessor control that a defrost cycle is needed and controls its termination, high pressure switch with automatic reset, compressor thermal overload protection, fans thermal overload protection.

### TEST

All the units are fully assembled and wired at the factory, carefully evacuated and dried after leak tests under pressure and then charged with refrigerant R410A.

They are all fully operational tested before shipment. They all conform to European Directives and are individually marked with the CE label and provided with Conformity Declaration.

## ACCESSORY DESCRIPTIONS

### HYGR - Remote mechanical hygostat

To be installed on the wall, it is supplied with a regulation knob and working range from 30% to 100% with precision of 3%.

### HOEL - Electric heater

The electric heater kit is in aluminium and is used to integrate the unit heating capacity. The kit is composed of an on-off double safety thermostat without capacity steps.

### HOWA - Hot water coil

The heat exchanger is made of copper pipes and aluminium fins. The diameter of the copper pipes is 3/8" and the thickness of the aluminium fins is 0,1 mm. The tubes are mechanically expanded into the aluminium fins to improve the heat exchange factor.

### INSE - Serial interface card RS485

This interface card enables the controller to communicate with other devices using Modbus protocol.

### KGBH - Louver kit and case for ducted version

Air grille double row adjustable brushed aluminium fins, equipped for wall mounting with subframe.

### KIVM - 3 way modulating valve kit

It is used to control the waterflow in the coil. The valve is directly controlled from the unit microprocessor.

### LS00 - Low noise version

This version includes the complete acoustic insulation of the unit (compressor + heat exchangers vanes) with compressor jackets and insulating material made with high density media and the interposition of heavy bitumen layer.

### PCRL - Remote control panel

This panel can be mounted up to 50m (maximum) from the unit and replicates all of the control functions. It is connected using a twin cable of 0.5 mm sq section.

### RGDD - Humidity and Temperature electronic probe sensor

Built-in Electronic temperature and humidity probe.

### PMBH - delivery and return plenum 90° (2 pieces)

To be used for "P" version to direct inlet/outlet air from/to swimming pool and vice versa. Galvanized steel made, coated with polyurethane powder to grant best resistance to weathering and operation in harsh environments.



## ACCESSORIES

SBA A		50	75	100	150	153	200	203
Built-in electronic control with display		●	●	●	●	●	●	●
Low noise version	LS00	●	●	●	●	●	●	●
Hot water coil	HOWA	○	○	○	○	○	○	○
Electric heater kit 3 kW	HOEL	○	○	○	-	-	-	-
Electric heater kit 4,5 kW	HOEL	-	-	-	-	○	-	○
Electric heater kit 6 kW	HOEL	-	-	-	○	-	○	-
Humidity / Temperature electronic probe sensor	RGDD	○	○	○	○	○	○	○
Remote mechanical hygrostat	HYGR	○	○	○	○	○	○	○
On/Off 3 way valve kit installed	KIVM	○	○	○	○	○	○	○
Delivery and return plenum 90° (2 pieces)	PMBH	-	-	-	-	-	-	-
Louver kit and case for ducted version	KGBH	-	-	-	-	-	-	-
Feet	ZOCC	○	○	○	○	○	○	○
Remote control Panel	PCRL	○	○	○	○	○	○	○
Serial interface card RS485	INSE	○	○	○	○	○	○	○

● Standard, ○ Optional, - Not available.

SBA P		50	75	100	150	153	200	203
Built-in electronic control with display		●	●	●	●	●	●	●
Low noise version	LS00	●	●	●	●	●	●	●
Hot water coil	HOWA	○	○	○	○	○	○	○
Electric heater kit 3 kW	HOEL	○	○	○	-	-	-	-
Electric heater kit 4,5 kW	HOEL	-	-	-	-	○	-	○
Electric heater kit 6 kW	HOEL	-	-	-	○	-	○	-
Humidity / Temperature electronic probe sensor	RGDD	○	○	○	○	○	○	○
Remote mechanical hygrostat	HYGR	○	○	○	○	○	○	○
On/Off 3 way valve kit installed	KIVM	○	○	○	○	○	○	○
Delivery and return plenum 90° (2 pieces)	PMBH	○	○	○	○	○	○	○
Louver kit and case for ducted version	KGBH	○	○	○	○	○	○	○
Feet	ZOCC	-	-	-	-	-	-	-
Remote control Panel	PCRL	○	○	○	○	○	○	○
Serial interface card RS485	INSE	○	○	○	○	○	○	○

● Standard, ○ Optional, - Not available.

SBA - A

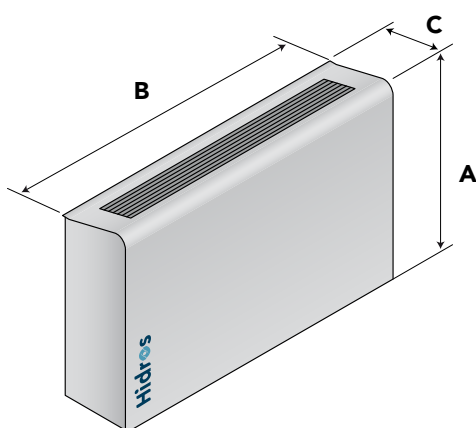

Mod.	A (mm)	B (mm)	C (mm)	kg
50	750	760	260	50
75	750	1060	260	64
100	750	1060	260	68
150/153	836	1310	310	99
200/203	836	1310	310	102

SBA - P

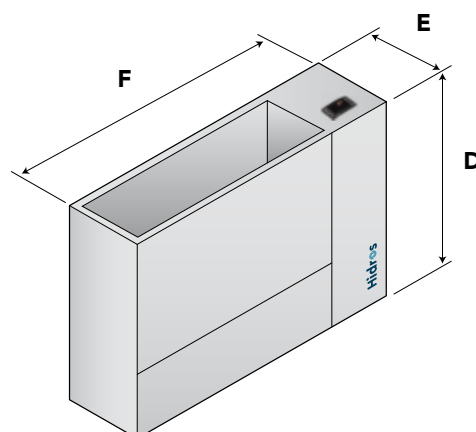

Mod.	D (mm)	E (mm)	F (mm)	kg
50	680	250	706	41
75	680	250	1006	57
100	680	250	1006	61
150/153	770	300	1255	82
200/203	770	300	1255	87

# SBA HT

## SWIMMING POOL DEHUMIDIFIERS FOR HIGH AMBIENT TEMPERATURE

Dehumidifying capacity from 20 l/24h to 187 l/24h  
Air flow from 500 m<sup>3</sup>/h to 1500 m<sup>3</sup>/h

---



The dehumidifiers of the SBA HT series are high-performance devices specifically designed for use in swimming pools where it is necessary to control the humidity rate, in order to prevent condensation and to ensure excellent environmental comfort. They are suitable for small swimming pools or whirlpool baths where a high ambient temperature up to 42°C is maintained.

These units, thanks to oversized exchangers and suitable components, have an extended operating range. The development of the machine reduces the overall dimensions allowing the insertion even in narrow spaces. The series consists of 5 models and covers a capacity range from 30 to 140 l/24h.

Temperature and humidity probes are accessories supplied on request.

### VERSIONS

- A** Version with cabinet
- P** Ductable units.

## TECHNICAL DATA

SBA/A-P		036	056	076	116	156	163
Moisture removed at 35°C - 80%	l/24h	43,4	76,9	92,2	149,6	178,7	187,0
Moisture removed at 30°C - 80%	l/24h	35,5	60,7	72,1	124,4	141,0	148,2
Moisture removed at 30°C - 60%	l/24h	23,8	39,4	48,5	95,5	106,8	111,7
Moisture removed at 27°C - 60%	l/24h	20,6	33,8	40,3	82,8	93,5	97,2
Nominal input power <sup>(1) (2)</sup>	kW	0,5	0,7	0,9	1,3	1,8	2,2
Maximum input power <sup>(2)</sup>	kW	0,7	1,0	1,1	2,2	2,7	2,7
Supplementary electric heater	kW	3,0	3,0	3,0	6,0	6,0	4,5
Maximum input current <sup>(2)</sup>	A	3,1	4,5	4,8	8,7	12,1	5,8
Peak current	A	14,0	20,0	20,0	39,0	45,0	29,0
Hot water coil <sup>(3)</sup>	kW	3,5	7,0	7,0	11,5	11,8	11,8
Air Flow	m <sup>3</sup> /h	500	650	650	1500	1500	1500
Refrigerant		R410A	R410A	R410A	R410A	R410A	R410A
Global warming potential (GWP)		2088	2088	2088	2088	2088	2088
Refrigerant charge	kg	0,30	0,50	0,52	1,00	1,20	1,20
Equivalent CO2 charge	t	0,63	1,04	1,09	2,09	2,51	2,51
Sound power <sup>(4)</sup>	dB(A)	54	57	57	59	61	61
Sound pressure <sup>(5)</sup>	dB(A)	47	50	50	52	54	54
Power supply	V/Ph/Hz	230/1/50	230/1/50	230/1/50	230/1/50	230/1/50	400/3+N/50

Performances are calculated with low fan speed and are referred to the following conditions:

(1) Temperature 30°C; Humidity 80%.

(2) Without electric heater.

(3) Room temperature 30°C; water temperature 80/70°C, at compressor OFF

(4) Sound power level calculated according to ISO 9614.

(5) Sound pressure level measured at 1 mt from the unit in free field conditions according to ISO 9614.

## OPERATION LIMITS

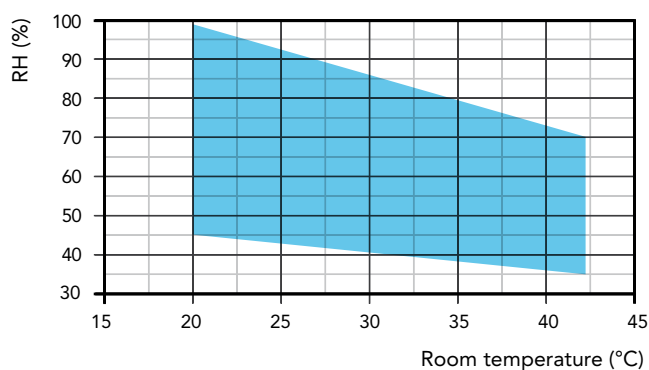

**Standard version (A)**

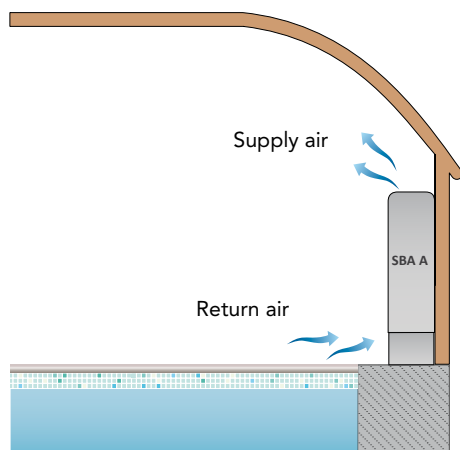

**Ducted version (P)**

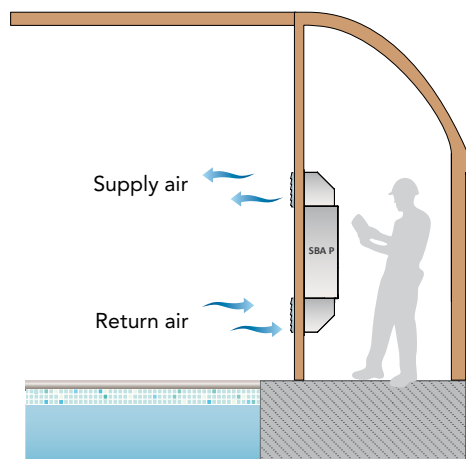

## COMPONENTS

### FRAME

All SBA units are made from hot-galvanised thick sheet metal, painted with polyurethane powder enamel at 180°C to ensure the best resistance against the atmospheric agents and to operate in aggressive environments. The frame is self-supporting with removable panels. A PVC drip tray is installed on all units. The colour of the unit is RAL 9010 both for the base and for the frontal panel.

### REFRIGERANT CIRCUIT

The refrigerant circuit is made by using international primary brands components and according to ISO 97/23 concerning welding procedures. The refrigerant gas used in these units is R410A.

The refrigerant circuit includes: capillary tube, Schrader valves for maintenance and control, pressure safety device (according to PED regulation).

### COMPRESSOR

The compressors are rotative type, with thermal overload protection by a klixon embedded in the motor winding. The compressor is mounted on rubber vibration dampers and it is supplied, standard, with sound-proof cover to reduce noise emission. The inspection is possible through the frontal panel of the unit that allows the maintenance of the compressor.

### CONDENSER AND EVAPORATOR

Condensers and evaporators are made of copper pipes and aluminium fins. All evaporators are painted with epoxy powders to prevent corrosion problem due to their use in aggressive environments. The diameter of the copper pipes is 3/8" and the thickness of the aluminium fins is 0,15 mm. The tubes are mechanically expanded into the aluminium fins to improve the heat exchange factor. The geometry of these heat exchangers guarantees a low air side pressure drop and then the use of low rotation (and low noise emission) fans. All units are supplied, standard, with a PVC drip tray and all evaporators are supplied with a temperature sensor used as automatic defrost probe.

### FAN

The fans are made of galvanized steel, centrifugal type. It is statically and dynamically balanced and supplied.

The electric motors are directly connected to the fan; they are all at 3 speeds, with integrated thermal protection. The protection class of the motors is IP 54.

### AIR FILTER

It is made of synthetic filtering media, ondulated type, without electro-static charge; they are all removable for differential disposal. Efficiency class coarse 30%, according to UNI EN ISO 16890:2017.

### MICROPROCESSOR

All units are supplied standard with microprocessor controls. The microprocessor controls the following functions: compressor timing, automatic defrost cycles, alarms.

An appropriate LCD display shows the operation mode of the unit, set point and alarms.

### ELECTRIC BOX

The electric switch board is made according to electromagnetic compatibility norms CEE 2014/35 and 2014/30. The accessibility to the board is possible after removing the front panel of the unit and the OFF positioning of the main switch. If the unit is endowed of cabinet, after its removal.

### CONTROL AND PROTECTION DEVICES

All units are supplied with the following control and protection devices: defrost thermostat, which signals to the microprocessor control that a defrost cycle is needed and controls its termination, high pressure switch with automatic reset, compressor thermal overload protection, fans thermal overload protection.

### TEST

All the units are fully assembled and wired at the factory, carefully evacuated and dried after leak tests under pressure and then charged with refrigerant R410A.

They are all fully operational tested before shipment. They all conform to European Directives and are individually marked with the CE label and provided with Conformity Declaration.

## ACCESSORY DESCRIPTIONS

### HYGR - Remote mechanical hygrost

To be installed on the wall, it is supplied with a regulation knob and working range from 30% to 100% with precision of 3%.

### HOEL - Electric heater

The electric heater kit is in aluminium and is used to integrate the unit heating capacity. The kit is composed of an on-off double safety thermostat without capacity steps.

### HOWA - Hot water coil

The heat exchanger is made of copper pipes and aluminium fins. The diameter of the copper pipes is 3/8" and the thickness of the aluminium fins is 0,1 mm. The tubes are mechanically expanded into the aluminium fins to improve the heat exchange factor.

### INSE - Serial interface card RS485

This interface card enables the controller to communicate with other devices using Modbus protocol.

### KGBH - Louver kit and case for ducted version

Air grille double row adjustable brushed aluminium fins, equipped for wall mounting with subframe.

### KIVM - 3 way modulating valve kit

It is used to control the waterflow in the coil. The valve is directly controlled from the unit microprocessor.

### LS00 - Low noise version

This version includes the complete acoustic insulation of the unit (compressor + heat exchangers vanes) with compressor jackets and insulating material made with high density media and the interposition of heavy bitumen layer.

PCRL - Remote control panel

This panel can be mounted up to 50m (maximum) from the unit and replicates all of the control functions. It is connected using a twin cable of 0.5 mm sq section.

### RGDD - Humidity and Temperature electronic probe sensor

Built-in Electronic temperature and humidity probe.

### PMBH - delivery and return plenum 90° (2 pieces)

To be used for "P" version to direct inlet/outlet air from/to swimming pool and vice versa. Galvanized steel made, coated with polyurethane powder to grant best resistance to weathering and operation in harsh environments.

## ACCESSORIES

SBA HT - A		36/A	56/A	76/A	116/A	156/A	163/A
Built-in electronic control with display		●	●	●	●	●	●
Low noise version	LS00	●	●	●	●	●	●
Hot water coil	HOWA	○	○	○	○	○	○
Electric heater kit 3 kW	HOEL	○	○	○	-	-	-
Electric heater kit 4,5 kW	HOEL	-	-	-	-	-	○
Electric heater kit 6 kW	HOEL	-	-	-	○	○	-
Humidity / Temperature electronic probe sensor	RGDD	○	○	○	○	○	○
Remote mechanical hygrostat	HYGR	○	○	○	○	○	○
On/Off 3 way valve kit installed	KIVM	○	○	○	○	○	○
Delivery and return plenum 90° (2 pieces)	PMBH	-	-	-	-	-	-
Louver kit and case for ducted version	KGBH	-	-	-	-	-	-
Feet	ZOCC	○	○	○	○	○	○
Remote control Panel	PCRL	○	○	○	○	○	○
Serial interface card RS485	INSE	○	○	○	○	○	○

● Standard, ○ Optional, - Not available.

SBA HT - P		36/P	56/P	76/P	116/P	156/P	163/P
Built-in electronic control with display		●	●	●	●	●	●
Low noise version	LS00	●	●	●	●	●	●
Hot water coil	HOWA	○	○	○	○	○	○
Electric heater kit 3 kW	HOEL	○	○	○	-	-	-
Electric heater kit 4,5 kW	HOEL	-	-	-	-	-	○
Electric heater kit 6 kW	HOEL	-	-	-	○	○	-
Humidity / Temperature electronic probe sensor	RGDD	○	○	○	○	○	○
Remote mechanical hygrostat	HYGR	○	○	○	○	○	○
On/Off 3 way valve kit installed	KIVM	○	○	○	○	○	○
Delivery and return plenum 90° (2 pieces)	PMBH	○	○	○	○	○	○
Louver kit and case for ducted version	KGBH	○	○	○	○	○	○
Feet	ZOCC	-	-	-	-	-	-
Remote control Panel	PCRL	○	○	○	○	○	○
Serial interface card RS485	INSE	○	○	○	○	○	○

● Standard, ○ Optional, - Not available.

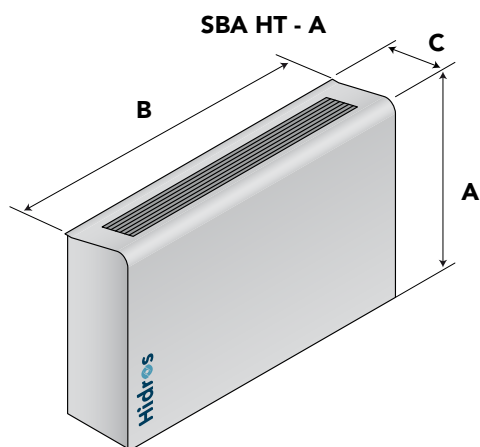

Mod.	A (mm)	B (mm)	C (mm)	kg
36	750	760	260	4
56-76	750	1060	260	63
116-156-163	836	1310	310	99

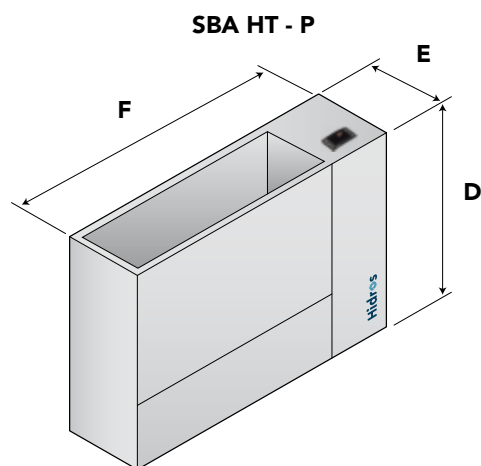

Mod.	D (mm)	E (mm)	F (mm)	kg
36	680	250	706	38
56-76	680	250	1006	56
116-156-163	770	300	1255	83

# SHA

## SWIMMING POOL DEHUMIDIFIERS

Dehumidifying capacity from 25 l/24h to 190 l/24h  
Air flow from 500 m<sup>3</sup>/h to 1650 m<sup>3</sup>/h

---



---

Series SHA dehumidifier are expressly designed for use in swimming pools where humidity should be closely controlled in order to guarantee optimal comfort. These units are intended to be installed in a technical room close to the swimming pool. A centrifugal fan with high available static pressure allows unit connection to ductworks, both for air suction and discharge. This series comprises 5 basic models which cover a capacity range from 50 to 190 l/24h. Temperature and humidity probes are accessories supplied on request.

### VERSIONS

The series includes 5 models with air flows from 500 to 1650 m<sup>3</sup>/h.

## TECHNICAL DATA

SHA		50	75	100	150	153	200	203
Moisture removed at 30°C - 80% l/24h		55,6	79,6	108,7	169,8	163,9	206,4	202,2
Moisture removed at 30°C - 60% l/24h		39,5	56,8	77,5	118,1	117,3	146,9	147,3
Moisture removed at 27°C - 60% l/24h		34,9	50,3	69,3	104,7	104,8	130,1	130,0
Moisture removed at 20°C - 60% l/24h		24,9	35,9	49,5	75,4	74,6	93,2	93,6
Nominal input power <sup>(1)</sup>	kW	0,7	1,3	1,7	2,0	2,1	2,7	2,7
Maximum input power <sup>(1)</sup>	kW	1,2	2,0	2,1	2,7	3,0	3,4	3,5
Supplementary electric heater	kW	3	3	3	6	4,5	6	4,5
Maximum input current	A	5,9	8,5	10,2	12,6	6,9	16,3	7,6
Peak current	A	19,9	25,6	38,6	41,2	29,2	64,2	32,2
Hot water coil <sup>(2)</sup>	kW	3,5	7,5	8,5	13,0	13,0	14,0	14,0
Partial heat recovery <sup>(3)</sup>	kW	--	1,1	1,7	2,3	2,3	3,0	3,0
Air Flow	m <sup>3</sup> /h	500	800	1000	1400	1400	1650	1650
Available static pressure	Pa	50÷150	50÷150	50÷150	50÷150	50÷150	50÷150	50÷150
Refrigerant		R410A	R410A	R410A	R410A	R410A	R410A	R410A
Global warming potential (GWP)		2088	2088	2088	2088	2088	2088	2088
Refrigerant charge	kg	71	74	76	82	82	84	84
Equivalent CO2 charge	t	58	60	62	67	67	69	69
Sound power <sup>(4)</sup>	dB(A)	57,0	59,0	61,0	66,5	66,5	68,5	68,5
Sound pressure <sup>(5)</sup>	dB(A)	50,0	52,0	54,0	59,5	59,5	61,5	61,5
Power supply	V/Ph/Hz	230/1/50	230/1/50	230/1/50	230/1/50	400/3+N/50	230/1/50	400/3+N/50

Performances are calculated with low fan speed and are referred to the following conditions:

(1)Temperature 30°C; Humidity 80%

(2)Room temperature 30°C; water temperature 80/70°C, at compressor OFF

(3)Room temperature 30°C/80%; water temperature 27/32°C.

(4) Sound power level calculated according to ISO EN 3744, fan with available static pressure 50 Pa.

(5) Sound pressure level measured at 1 mt from the unit in free field conditions according to ISO EN 3744.

### PLANT SCHEME

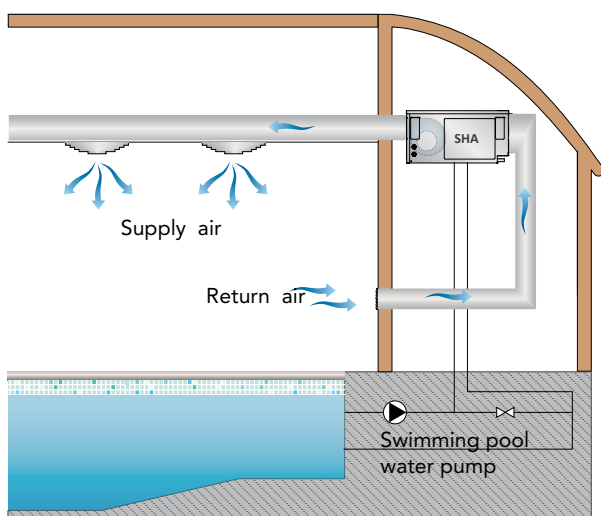

### OPERATION LIMITS

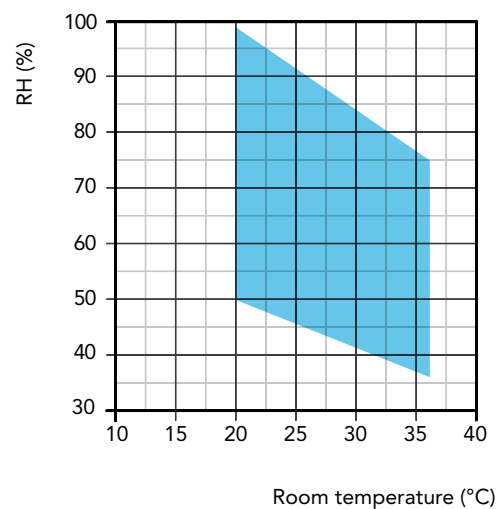

## COMPONENTS

### FRAME

All SHA units are made from hot-galvanised thick sheet metal, painted with polyurethane powder enamel at 180°C to ensure the best resistance against the atmospheric agents. The frame is self-supporting with removable panels. All screws and rivets are in stainless steel. The colour of the units is RAL 9018.

### REFRIGERANT CIRCUIT

The refrigerant gas used in these units is R410A. The refrigerant circuit is made by using international primary brands components and according to ISO 97/23 concerning welding procedures.

The refrigerant circuit includes: sight glass, filter drier, thermal expansion valve with external equalizer, Schrader valves for maintenance and control, pressure safety device (according to PED regulation).

### COMPRESSOR

The compressors are rotary with crankcase heater and thermal overload protection by a klixon embedded in the motor winding. The compressors are mounted on rubber vibration dampers, supplied with sound attenuation jacket to reduce the noise emission.

The inspection on the compressors is possible only through the unit front panel.

### CONDENSER AND EVAPORATOR

Condensers and evaporators are made of copper pipes and aluminium fins. All evaporators are painted with epoxy powders to prevent corrosion problem due to their use in aggressive environments. The diameter of the copper pipes is 3/8" and the thickness of the aluminium fins is 0,1 mm. The tubes are mechanically expanded into the aluminium fins to improve the heat exchange factor. The geometry of these heat exchangers guarantees a low air side pressure drop and then the use of low rotation (and low noise emission) fans.

All units are supplied, standard, with a painted steel drip tray and all evaporators are supplied with a temperature sensor used as automatic defrost probe.

### FAN

The fans are made of galvanized steel, centrifugal type. It is statically and dynamically balanced and supplied.

The electric motors are directly connected to the fan; they are all at 3 speeds, with integrated thermal protection. The protection class of the motors is IP 54.

### AIR FILTER

It is made of synthetic filtering media, undulated type, without electro-static charge; they are all removable for differential disposal, ePM10 50% according to UNI EN ISO 16890:2017.

### MICROPROCESSOR

All units are supplied standard with microprocessor controls. The microprocessor controls the following functions: compressor timing, automatic defrost cycles, alarms.

An appropriate LCD display shows the operation mode of the unit, set point and alarms.

### ELECTRIC BOX

The electric switch board is made according to electromagnetic compatibility norms CEE 2014/35 and 2014/30. The accessibility to the board is possible after removing the front panel of the unit and the OFF positioning of the main switch. The following components are also standard installed: main switch, magnetic-

thermal switches (as a protection fans and compressors), control circuit automatic breakers, compressor contactors, fan contactors. The terminal board is supplied with voltage free contacts for remote ON-OFF and general alarm.

### CONTROL AND PROTECTION DEVICES

All units are supplied with the following control and protection devices: antifreeze protection sensor, high pressure switch with manual reset, low pressure switch with automatic reset, high pressure safety valve, compressor thermal overload protection, fans thermal overload protection.

### TEST

All the units are fully assembled and wired at the factory, carefully evacuated and dried after leak tests under pressure and then charged with refrigerant R410A.

They are all fully operational tested before shipment. They all conform to European Directives and are individually marked with the CE label and provided with Conformity Declaration.

## ACCESSORY DESCRIPTIONS

### CANA - Delivery flange for channel connection

Press-folded rectangular flange for connection to the ducts and installed on the fan expulsion mouth.

### HYGR - Remote mechanical hygostat

To be installed on the wall, it is supplied with a regulation knob and working range from 30% to 100% with precision of 3%.

### HOEL - Electric heater

The electric heater kit is in aluminium and is used to integrate the unit heating capacity. The kit is composed of an on-off double safety thermostat without capacity steps.

### HOWA - Hot water coil

The heat exchanger is made of copper pipes and aluminium fins. The diameter of the copper pipes is 3/8" and the thickness of the aluminium fins is 0,1 mm. The tubes are mechanically expanded into the aluminium fins to improve the heat exchange factor.

### INSE - Serial interface card RS485

This interface card enables the controller to communicate with other devices using Modbus protocol.

### KGBH - Louver kit and case for ducted version

Air grille double row adjustable brushed aluminium fins, equipped for wall mounting with subframe.

### KIVM - 3 way modulating valve kit

It is used to control the waterflow in the coil. The valve is directly controlled from the unit microprocessor.

### LS00 - Low noise version

This version includes the complete acoustic insulation of the unit (compressor + heat exchangers vanes) with compressor jackets and insulating material made with high density media and the interposition of heavy bitumen layer.

### PCRL - Remote control panel

This panel can be mounted up to 50m (maximum) from the unit and replicates all of the control functions. It is connected using a twin cable of 0.5 mm sq section.



**RGDD - Humidity and Temperature electronic probe sensor**

Built-in Electronic temperature and humidity probe.

**RP01 - Partial heat recovery**

The unit is fitted with a Coaxial type heat exchanger suitable for chlorinated water. The internal pipe is manufactured from Cupronickel with the external pipe being made from Copper. The chlorinated water flows within the internal pipe whilst the refrigerant gas passes through the gap between the internal and external pipes. The Cupro-nickel internal pipe is manufactured with a special profile that generates turbulent flow within the refrigerant gas thus increasing the heat exchange factor, the thermal efficiency and reducing the dimensions. The heat exchanger is designed to recover approx. 20% of the thermal capacity generated by the unit.

**VECE - E.C. supply fan**

The supply fan is a high performance centrifugal type, double inlet forward curved blades, directly coupled to the electric motor. The fan wheel and the scroll are made from hot galvanised thick sheet metal, painted with polyurethane powders, to ensure the best resistance against aggressive environments. The electric motor is a high efficiency DC brushless type with external rotor, to guarantee an ideal cooling of the windings and the absence of power lost due to pulleys and belt transmission. The fan is statically and dynamically balanced class 6,3 according to ISO1940. The electric motor has a separate electronic commutator (driver) and a speed modulation 0-10V, integrated PFC, burn out thermal protection (in case of considerable reduction of the power supply), protection degree IP54, serial interface card with modbus protocol RTU.

**ACCESSORIES**

SHA		50	75	100	150	153	200	203
Low noise version	LS00	●	●	●	●	●	●	●
Supply flange	CANA	●	●	●	●	●	●	●
Humidity and Temperature electronic probe sensor	RGDD	○	○	○	○	○	○	○
Remote mechanical hygrostat	HYGR	○	○	○	○	○	○	○
Partial heat recovery Cu-Ni made	RP01	-	○	○	○	○	○	○
Hot water coil	HOWA	○	○	○	○	○	○	○
Modulating 3 way valve kit installed	KIVM	○	○	○	○	○	○	○
Electric heater kit 3 kW (230/1~/50)	HOEL	○	○	○	○	-	○	-
Electric heater kit 4,5 kW (230/1~/50)	HOEL	-	-	-	-	○	-	○
Electric heater kit 6 kW (230/1~/50)	HOEL	○	○	○	○	-	○	-
Louver kit and case	KGBH	○	○	○	○	○	○	○
Remote control panel	PCRL	○	○	○	○	○	○	○
High efficiency E.C. fans ≤ 300 Pa	V1CE	○	○	○	○	○	○	○
Serial interface card RS485	INSE	○	○	○	○	○	○	○

● Standard, ○ Optional, - Not Available.

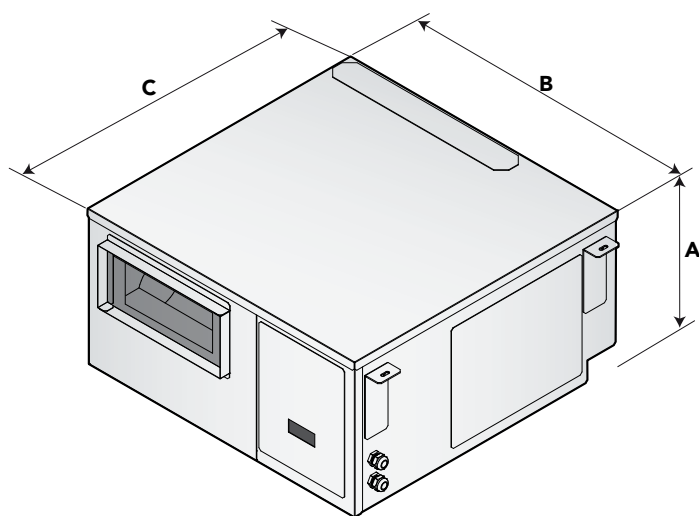

Mod.	A (mm)	B (mm)	C (mm)	kg
50	360	700	710	63
75	460	980	900	95
100	460	980	900	122
150/153	530	1160	1050	131
200/203	530	1160	1050	140

# SDA

## SWIMMING POOL DEHUMIDIFIERS

Dehumidifying capacity from 35 l/24h to 200 l/24h  
Air flow from 800 m<sup>3</sup>/h to 1800 m<sup>3</sup>/h

---



---

Series SDA dehumidifier are expressly designed for use in swimming pools where humidity should be closely controlled in order to guarantee optimal comfort. These units are intended to be installed in a technical room close to the swimming pool. A centrifugal fan with high available static pressure allows unit connection to ductworks, both for air suction and discharge. This series comprises 6 basic models which cover a capacity range from 73 to 240 l/24h. Temperature and humidity probes are accessories supplied on request.

### VERSIONS

The series includes 4 models with air flows from 800 to 1800 m<sup>3</sup>/h.

## TECHNICAL DATA

SDA		75	100	150	153	200	203
Moisture removed at 30°C - 80%	l/24h	78,4	108,2	163,7	163,7	205,9	205,9
Moisture removed at 30°C - 60%	l/24h	56,3	77,2	113,1	113,1	144,7	144,7
Moisture removed at 27°C - 60%	l/24h	49,5	68,2	100,0	100,0	128,3	128,3
Moisture removed at 20°C - 60%	l/24h	35,4	49,1	72,3	72,3	91,4	91,4
Nominal input power at 30°C - 80% <sup>(1)</sup>	kW	1,4	1,8	2,2	2,2	2,8	2,8
Maximum input power <sup>(1)</sup>	kW	1,9	2,1	2,9	2,9	3,6	3,6
Supplementary electric heater	kW	3,0	3,0	6,0	4,5	6,0	4,5
Maximum input current <sup>(1)</sup>	A	8,0	9,7	13,0	13,0	16,7	16,7
Peak current	A	25,1	38,1	41,6	41,6	64,6	64,6
Hot water coil <sup>(2)</sup>	kW	7,5	8,5	13,9	13,9	15,2	15,2
Partial heat recovery <sup>(3)</sup>	kW	1,1	1,7	2,3	2,3	3,0	3,0
Air Flow	m <sup>3</sup> /h	800	1000	1500	1500	1800	1800
Available static pressure	Pa	50÷150	50÷150	50÷150	50÷150	50÷150	50÷150
Refrigerant		R410A	R410A	R410A	R410A	R410A	R410A
Global warming potential (GWP)		2088	2088	2088	2088	2088	2088
Refrigerant charge	kg	0,55	0,55	1,10	1,10	1,10	1,10
Equivalent CO2 charge	t	1,15	1,15	2,30	2,30	2,30	2,30
Sound power <sup>(4)</sup>	dB(A)	73	75	81	81	83	83
Sound pressure <sup>(5)</sup>	dB(A)	59	61	66	66	68	68
Power supply	V/Ph/Hz	230/1/50	230/1/50	230/1/50	400/3+N/50	230/1/50	400/3+N/50

Performances are calculated with low fan speed and are referred to the following conditions:

(1) Without electric heater.

(2) Room temperature 30°C; water temperature 80/70°C, compressor OFF

(3) Room temperature 30°C/80%; water temperature 27/32°C, compressor OFF

(4) Sound Power level according to ISO EN 3744 fan with available static pressure 50 Pa.

(5) Sound Pressure level measured at 1 mt from the unit in free field conditions according with ISO EN 3744, fan with available static pressure 50 Pa.

### PLANT SCHEME

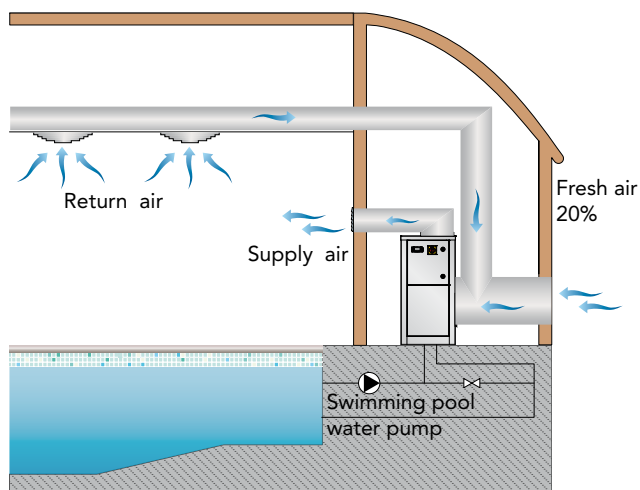

### OPERATION LIMITS

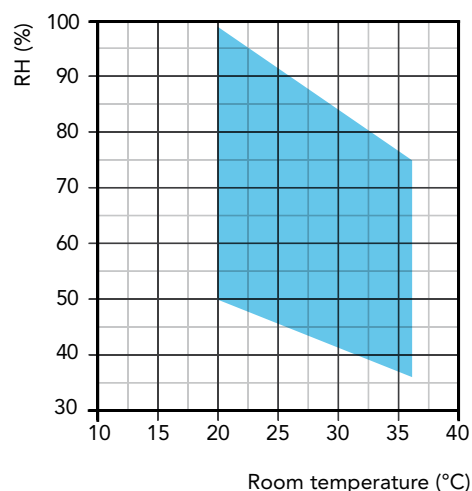

## COMPONENTS

### FRAME

All units are made from hot-galvanised thick sheet metal, painted with polyurethane powder enamel at 180°C to ensure the best resistance against the atmospheric agents. The frame is self-supporting with removable panels. All screws and rivets are in stainless steel. The colour of the units is RAL 9018.

### REFRIGERANT CIRCUIT

The refrigerant gas used in these units is R410A. The refrigerant circuit is made by using international primary brands components and according to ISO 97/23 concerning welding procedures.

The refrigerant circuit includes: sight glass, filter drier, thermal expansion valve with external equalizer, Schrader valves for maintenance and control, pressure safety device (according to PED regulation).

### COMPRESSOR

The compressors are rotative type, with thermal overload protection by a klixon embedded in the motor winding. The compressor is mounted on rubber vibration dampers and it is supplied, standard, with sound-proof cover to reduce noise emission. The inspection is possible through the frontal panel of the unit that allows the maintenance of the compressor.

### CONDENSER AND EVAPORATOR

Condensers and evaporators are made of copper pipes and aluminium fins.

All evaporators are painted with epoxy powders to prevent corrosion problem due to their use in aggressive environments. The diameter of the copper pipes is 3/8" and the thickness of the aluminium fins is 0,1 mm. The tubes are mechanically expanded into the aluminium fins to improve the heat exchange factor. The geometry of these heat exchangers guarantees a low air side pressure drop and then the use of low rotation (and low noise emission) fans.

All units are supplied, standard, with a powder coated steel drip tray and all evaporators are supplied with a temperature sensor used as automatic defrost probe.

### FAN

The fans are made of galvanized steel, centrifugal type. It is statically and dynamically balanced and supplied.

The electric motors are directly connected to the fan; they are all at 3 speeds, with integrated thermal protection. The protection class of the motors is IP 54.

### AIR FILTER

It is made of synthetic filtering media, undulated type, without electro-static charge; they are all removable for differential disposal, ePM10 50% according to UNI EN ISO 16890:2017.

### MICROPROCESSOR

All units are supplied standard with microprocessor controls. The microprocessor controls the following functions: compressor timing, automatic defrost cycles, alarms.

An appropriate LCD display shows the operation mode of the unit, set point and alarms.

### ELECTRIC BOX

The electric switch board is made according to electromagnetic compatibility norms CEE 2014/35 and 2014/30. The accessibility to the board is possible after removing the front panel of the unit and the OFF positioning of the main switch. The following components are also standard installed: main switch, magnetic-thermal switches (as a protection fans and compressors), control circuit automatic breakers, compressor contactors, fan contactors. The terminal board is supplied with voltage free contacts for remote ON-OFF and general alarm.

### CONTROL AND PROTECTION DEVICES

All units are supplied with the following control and protection devices: antifreeze protection sensor, high pressure switch with manual reset, low pressure switch with automatic reset, high pressure safety valve, compressor thermal overload protection, fans thermal overload protection.

### TEST

All the units are fully assembled and wired at the factory, carefully evacuated and dried after leak tests under pressure and then charged with refrigerant R410A.

They are all fully operational tested before shipment. They all conform to European Directives and are individually marked with the CE label and provided with Conformity Declaration.

## ACCESSORY DESCRIPTIONS

### CANA - Delivery flange for channel connection

Press-folded rectangular flange for connection to the ducts and installed on the fan expulsion mouth.

### HYGR - Remote mechanical hygostat

To be installed on the wall, it is supplied with a regulation knob and working range from 30% to 100% with precision of 3%.

### HOEL - Electric heater

The electric heater kit is in aluminium and is used to integrate the unit heating capacity. The kit is composed of an on-off double safety thermostat without capacity steps.

### HOWA - Hot water coil

The heat exchanger is made of copper pipes and aluminium fins. The diameter of the copper pipes is 3/8" and the thickness of the aluminium fins is 0,1 mm. The tubes are mechanically expanded into the aluminium fins to improve the heat exchange factor.

### INSE - Serial interface card RS485

This interface card enables the controller to communicate with other devices using Modbus protocol.

### KIVM - 3 Way modulating valve kit

It is used to control the waterflow in the coil. The valve is directly controlled from the unit microprocessor.

### LS00 - Low noise version

This version includes the complete acoustic insulation of the unit (compressor + heat exchangers vanes) with compressor jackets and insulating material made with high density media and the interposition of heavy bitumen layer.

### PCRL - Remote control panel

This panel can be mounted up to 50m (maximum) from the unit and replicates all of the control functions. It is connected using a twin cable of 0.5 mm sq section.

### RGDD - Humidity and Temperature electronic probe sensor

Built-in Electronic temperature and humidity probe.

### RP01 - Partial heat recovery

The unit is fitted with a Coaxial type heat exchanger suitable for chlorinated water. The internal pipe is manufactured from Cupronickel with the external pipe being made from Copper. The chlorinated water flows within the internal pipe whilst the refrigerant gas passes through the gap between the internal and external pipes. The Cupronickel internal pipe is manufactured with a special profile that generates turbulent flow within the refrigerant.

ant gas thus increasing the heat exchange factor, the thermal efficiency and reducing the dimensions. The heat exchanger is designed to recover approx. 20% of the thermal capacity generated by the unit.

**V1CE - E.C. supply fan**

The supply fan is a high performance centrifugal type, double inlet forward curved blades, directly coupled to the electric motor. The fan wheel and the scroll are made from hot galvanised thick sheet metal, painted with polyurethane powders, to ensure the best resistance against aggressive environments. The electric motor is a high efficiency DC brushless type with exter-

nal rotor, to guarantee an ideal cooling of the windings and the absence of power lost due to pulleys and belt transmission. The fan is statically and dynamically balanced class 6,3 according to ISO1940. The electric motor has a separate electronic commutator (driver) and a speed modulation 0-10V, integrated PFC, burn out thermal protection (in case of considerable reduction of the power supply), protection degree IP54, serial interface card with modbus protocol RTU.

**ACCESSORIES**

SDA		75	100	150	153	200	203
A.C. fans ≤ 150 Pa		●	●	●	●	●	●
Supply flange	CANA	●	●	●	●	●	●
Thermostatic valve		●	●	●	●	●	●
Low noise version	LS00	●	●	●	●	●	●
Main switch		●	●	●	●	●	●
Humidity and Temperature electronic probe sensor	RGDD	○	○	○	○	○	○
Remote mechanical hygrostat	HYGR	○	○	○	○	○	○
Partial heat recovery Cu-Ni made	RP01	-	○	○	○	○	○
Hot water coil	HOWA	○	○	○	○	○	○
Modulating 3 way valve kit installed	KIVM	○	○	○	○	○	○
Electric heater kit 3 kW (230/1~/50)	HOEL	○	○	○	-	○	-
Electric heater kit 4,5 kW (230/1~/50)	HOEL	-	-	-	○	-	○
Electric heater kit 6 kW (230/1~/50)	HOEL	-	-	○	-	○	-
Stainless steel frame	INOX	○	○	○	○	○	○
Air filter with frame for ducted installation	FARC	○	○	○	○	○	○
Remote control Panel	PCRL	○	○	○	○	○	○
High efficiency E.C. fans ≤ 300 Pa	V1CE	○	○	○	○	○	○
Serial interface card RS485	INSE	○	○	○	○	○	○
Rubber vibration dampers	KAVG	○	○	○	○	○	○

● Standard, ○ Optional, - Not Available.

**CONFIGURATIONS**

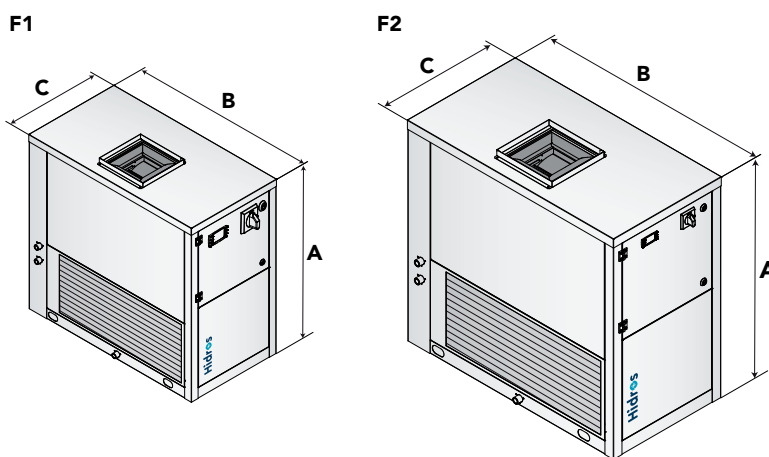
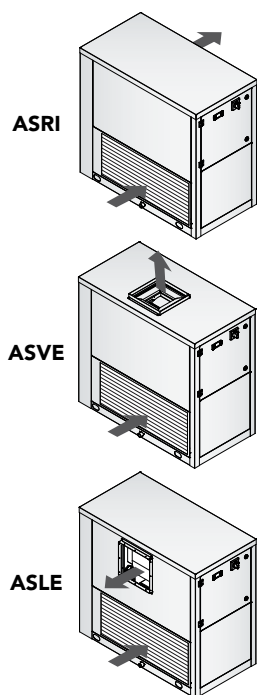

Mod.	Frame	A (mm)	B (mm)	C (mm)	kg
75	F1	800	800	400	85
100	F1	800	800	400	90
150/153	F2	1000	1060	550	130
200/203	F2	1000	1060	550	135

# NSA

## SWIMMING POOL DEHUMIDIFIERS

Dehumidifying capacity from 260 l/24h to 940 l/24h

Air flow from 3500 m<sup>3</sup>/h to 8500 m<sup>3</sup>/h



NSA with FARC option

Series NSA dehumidifier are expressly designed for use in swimming pools where humidity should be closely controlled in order to guarantee optimal comfort. These units are intended to be installed in a technical room close to the swimming pool. A centrifugal fan with high available static pressure allows unit connection to ductworks, both for air suction and discharge. This series comprises 6 basic models which cover a capacity range from 263 to 940 l/24h. Temperature and humidity probes are accessories supplied on request.

### VERSIONS

The series includes 6 models with air flows from 3500 to 8500 m<sup>3</sup>/h.

## TECHNICAL DATA

NSA		275	355	455	555	755	955
Moisture removed at 30°C - 80%	l/24h	254,2	353,2	466,7	600,2	845,9	1028,0
Moisture removed at 30°C - 60%	l/24h	183,7	266,0	340,1	436,1	605,3	766,3
Moisture removed at 27°C - 60%	l/24h	162,0	234,3	303,0	377,1	536,2	682,7
Moisture removed at 20°C - 60%	l/24h	113,2	170,6	221,6	264,2	386,5	508,2
Total cooling cap. (30°C-80% - 35°C ext)	kW	12,93	16,96	19,83	25,57	35,56	43,17
Sensible cooling cap. (30°C-80% - 35°C ext)	kW	4,48	5,91	7,20	8,80	12,45	15,50
Nominal input power at 30°C-80%	kW	4,4	5,6	8,8	9,9	16,0	19,7
Maximum input power	kW	6,4	7,8	10,5	10,6	17,6	20,8
Maximum input current	A	10,8	13,0	17,1	18,3	28,6	35,2
Peak current	A	51,0	66,0	76,0	98,6	103,0	151,0
Air Flow indoor unit	m <sup>3</sup> /h	3500	4200	4200	5500	7000	8500
Air Flow outdoor unit	m <sup>3</sup> /h	7500	7100	6700	15000	14200	21300
Available static pressure	Pa	50	50	50	50	50	50
Refrigerant		R410A	R410A	R410A	R410A	R410A	R410A
Refrigerant charge	kg	3,00	2,50	2,50	9,00	8,00	8,00
Global warming potential (GWP)		2088	2088	2088	2088	2088	2088
Equivalent CO <sub>2</sub> charge	t	6,26	5,22	5,22	18,79	16,70	16,70
Sound power <sup>(1)</sup>	dB(A)	84	85	85	87	87	87
Sound pressure <sup>(2)</sup>	dB(A)	68	69	69	70	70	70
Sound pressure <sup>(3)</sup>	dB(A)	53	54	54	55	55	55
Power supply	V/Ph/Hz	400/3+N/50	400/3+N/50	400/3+N/50	400/3+N/50	400/3+N/50	400/3+N/50

Performances are calculated with low fan speed and are referred to the following conditions:

(1) Sound Power level according to ISO EN 3744 fan with available static pressure 50 Pa.

(2) Sound pressure level measured at 1 mt from the unit in free field conditions according to ISO EN 3744. fan with available static pressure 50 Pa.

(3) Sound pressure level measured at 10 mt from the unit in free field conditions according to ISO EN 3744. fan with available static pressure 50 Pa.

### PLANT SCHEME

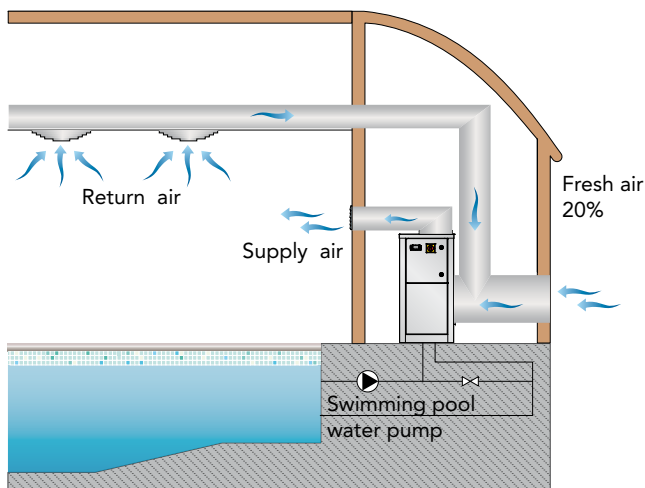

### OPERATION LIMITS

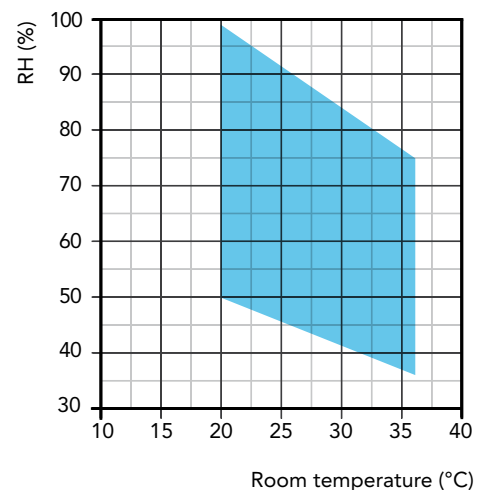

## COMPONENTS

### FRAME

All units are made from hot-galvanised thick sheet metal, painted with polyurethane powder enamel at 180°C to ensure the best resistance against the atmospheric agents. The frame is self-supporting with removable panels. All screws and rivets are in stainless steel. The colour of the units is RAL 9018.

### REFRIGERANT CIRCUIT

The refrigerant gas used in these units is R410A. The refrigerant circuit is made by using international primary brands components and according to ISO 97/23 concerning welding procedures.

The refrigerant circuit includes: sight glass, filter drier, thermal expansion valve with external equalizer, Schrader valves for maintenance and control, pressure safety device (according to PED regulation).

### COMPRESSOR

The compressors are rotative type, with thermal overload protection by a klixon embedded in the motor winding. The compressor is mounted on rubber vibration dampers and it is supplied, on request, with sound-proof cover (optional) to reduce noise emission. The inspection is possible through the frontal panel of the unit that allows the maintenance of the compressor.

### CONDENSER AND EVAPORATOR

Condensers and evaporators are made of copper pipes and aluminium fins. All evaporators are painted with epoxy powders to prevent corrosion problem due to their use in aggressive environments. The diameter of the copper pipes is 3/8" and the thickness of the aluminium fins is 0,1 mm. The tubes are mechanically expanded into the aluminium fins to improve the heat exchange factor. The geometry of these heat exchangers guarantees a low air side pressure drop and then the use of low rotation (and low noise emission) fans. All units are supplied, standard, with a powder coated steel drip tray and all evaporators are supplied with a temperature sensor used as defrost probe.

### SUPPLY FAN

The fans are made of galvanized steel, centrifugal type. It is statically and dynamically balanced and supplied. The electric motors are directly connected to the fan; they are all at 2 speeds, with integrated thermal protection. The protection class of the motors is IP 54. The fans are painted with epoxy powder to prevent problems when used in aggressive environments.

### AIR FILTER

It is made of synthetic filtering media, undulated type, without electro-static charge; they are all removable for differential disposal, ePM10 50% according to UNI EN ISO 16890:2017.

### MICROPROCESSOR

All units are supplied standard with microprocessor controls. The microprocessor controls the following functions: compressor timing, automatic defrost cycles, alarms. An appropriate LCD display shows the operation mode of the unit, set point and alarms.

### ELECTRIC BOX

The electric switch board is made according to electromagnetic compatibility norms CEE 2014/35 and 2014/30. The accessibility to the board is possible after removing the front panel of the unit and the OFF positioning of the main switch. The following components are also standard installed: main switch, magnetic-thermal switches (as a protection fans and compressors), control circuit automatic breakers, compressor contactors, fan contactors. The terminal board is supplied with voltage free contacts for remote ON-OFF and general alarm.

### CONTROL AND PROTECTION DEVICES

All units are supplied with the following control and protection devices: antifreeze protection sensor, high pressure switch with manual reset, low pressure switch with automatic reset, high pressure safety valve, compressor thermal overload protection, fans thermal overload protection.

### TEST

All the units are fully assembled and wired at the factory, carefully evacuated and dried after leak tests under pressure and then charged with refrigerant R410A.

They are all fully operational tested before shipment. They all conform to European Directives and are individually marked with the CE label and provided with Conformity Declaration.

## ACCESSORY DESCRIPTIONS

### CANA - Delivery flange for channel connection

Press-folded rectangular flange for connection to the ducts and installed on the fan expulsion mouth.

### FARC - Air filter with frame for ducted installation

Complete with high efficiency air filter which can be removed by the side and frame for ducted installation.

### HBSSEL - HOEL - Electric heater 9kW/18kW

The electric heater kit is in aluminium and is used to integrate the unit heating capacity. The kit is composed of an on-off double safety thermostat without capacity steps.

### HOWA - Hot water coil

The heat exchanger is made of copper pipes and aluminium fins. The diameter of the copper pipes is 3/8" and the thickness of the aluminium fins is 0,1 mm. The tubes are mechanically expanded into the aluminium fins to improve the heat exchange factor.

### HYGR- Remote mechanical hygostat + thermostat

To be installed on the wall, it is supplied with a regulation knob and working range from 30% to 100% with precision of 3%.

### INOX - Stainless steel frame

It's used to ensure the best resistance against the atmospheric agents and the operation in aggressive environments. The frame is made of stainless steel AISI 304, self-supporting with removable panels to facilitate inspection and maintenance of internal components. All screws and rivets are in stainless steel.

### KAVG - Rubber vibration dampers

To be installed beneath the unit base and the ground to avoid the transmission of vibrations (and the noise) to the building.

### KIWA - 3 Way on/off valve

It is used to control the waterflow in the coil. The valve is directly controlled from the unit microprocessor.

### LSMC - Compressor soundproofing

Compressor jackets with high density insulation material.

### RP01 - Partial heat recovery

The unit is fitted with a Coaxial type heat exchanger suitable for chlorinated water. The internal pipe is manufactured from Cupronickel with the external pipe being made from Copper. The chlorinated water flows within the internal pipe whilst the refrigerant gas passes through the gap between the internal and external pipes. The Cupronickel internal pipe is manufactured with a special profile that generates turbulent flow within the re-



frigerant gas thus increasing the heat exchange factor, the thermal efficiency and reducing the dimensions. The heat exchanger is designed to recover approx. 20% of the thermal capacity generated by the unit.

### V1CE - E.C. supply fan

The supply fan is a high performance centrifugal type, double inlet forward curved blades, directly coupled to the electric motor. The fan wheel and the scroll are made from hot galvanised thick sheet metal, painted with polyurethane powders, to ensure the best resistance against aggressive environments. The electric motor is a high efficiency DC brushless type with external rotor, to guarantee an ideal cooling of the windings and the absence of power lost due to pulleys and belt transmission. The

fan is statically and dynamically balanced class 6,3 according to ISO1940. The electric motor has a separate electronic commutator (driver) and a speed modulation 0-10V, integrated PFC, burn out thermal protection (in case of considerable reduction of the power supply), protection degree IP54, serial interface card with modbus protocol RTU.

## ACCESSORIES

NSA		275	355	455	555	755	955
Main switch		●	●	●	●	●	●
Supply flange	CANA	○	○	○	○	○	○
Air filter with frame for ducted installation	FARC	○	○	○	○	○	○
A.C. fan with available static pressure up to 150 Pa	HAPS	○	○	○	○	○	○
Electric heater kit 18kW	HBSEL	-	-	-	○	○	○
Electric heater kit 9 kW	HOEL	○	○	○	○	○	○
Hot water coil	HOWA	○	○	○	○	○	○
Remote mechanical hygrostat	HYGR	○	○	○	○	○	○
Stainless steel frame	INOX	○	○	○	○	○	○
Rubber vibration dampers	KAVG	○	○	○	○	○	○
3 Way on/off valve	KIWA	○	○	○	○	○	○
Compressor soundproofing	LSMC	○	○	○	○	○	○
Partial heat recovery Cu-Ni made	RP01	○	○	○	○	○	○
High efficiency E.C. fans ≤ 300 Pa	V1CE	○	○	○	○	○	○

● Standard, ○ Optional, - Not Available.

## POSSIBLE CONFIGURATIONS

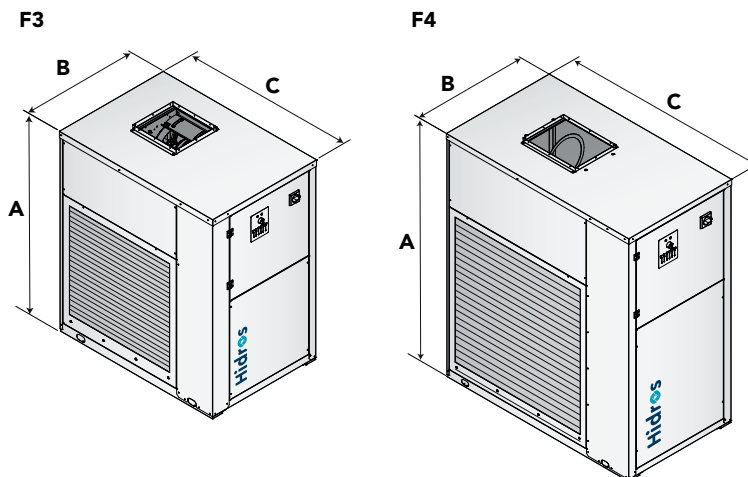
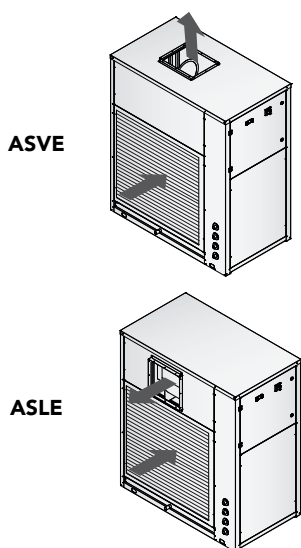

Mod.	Frame	A (mm)	B (mm)	C (mm)	kg
275	F3	1261	758	1118	204
355	F3	1261	758	1118	208
455	F3	1261	758	1118	212
555	F4	1753	858	1519	412
755	F4	1753	858	1519	420
955	F4	1753	858	1519	427

# SMA

## SWIMMING POOL DEHUMIDIFIERS

Dehumidifying capacity from 111 l/24h to 940 l/24h  
Air flow from 3500 m<sup>3</sup>/h to 8500 m<sup>3</sup>/h

---

R410A



---

Series SMA dehumidifier are expressly designed for use in swimming pools where humidity should be closely controlled in order to guarantee optimal comfort. These units are intended to be installed in a technical room close to the swimming pool. A centrifugal fan with high available static pressure allows unit connection to ductworks, both for air suction and discharge. This series comprises 6 basic models which cover a capacity range from 263 to 940 l/24h. Temperature and humidity probes are accessories supplied on request.

### VERSIONS

The series includes 6 models with air flows from 3500 to 8500 m<sup>3</sup>/h.

## TECHNICAL DATA

SMA		270	350	450	550	750	950
Moisture removed at 30°C - 80%	l/24h	254,2	353,3	466,7	600,2	845,9	1028,0
Moisture removed at 30°C - 60%	l/24h	183,7	266,0	340,1	436,1	605,3	766,3
Moisture removed at 27°C - 60%	l/24h	162,0	234,3	303,0	377,1	536,2	682,7
Moisture removed at 20°C - 60%	l/24h	113,2	170,6	221,6	264,2	386,5	508,2
Nominal input power at 30°C - 80% <sup>(1)</sup>	kW	4,1	5,3	8,1	9,2	14,3	18,1
Maximum input power <sup>(1)</sup>	kW	6,4	7,8	10,5	10,6	17,6	20,8
Supplementary electric heater	kW	9,0	9,0	9,0	18,0	18,0	18,0
Maximum input current <sup>(1)</sup>	A	10,8	13,0	17,1	18,3	28,6	35,2
Peak current	A	51,0	66,0	76,0	98,6	103,0	151,0
Hot water coil <sup>(2)</sup>	kW	22,8	24,0	24,0	42,0	49,0	56,0
Partial heat recovery <sup>(3)</sup>	kW	1,8	2,2	2,7	3,5	---	---
Air Flow	m <sup>3</sup> /h	3500	4200	4200	5500	7000	8500
Available static pressure	Pa	50÷150	50÷150	50÷150	50÷150	50÷150	50÷150
Refrigerant		R410a	R410a	R410a	R410a	R410a	R410a
Global warming potential (GWP)		2088	2088	2088	2088	2088	2088
Refrigerant charge	kg	3,00	2,50	2,50	6,3	6,6	7,0
Equivalent CO2 charge	t	6,26	5,22	5,22	13,15	13,78	14,61
Sound power <sup>(4)</sup>	dB(A)	84	85	85	87	87	87
Sound pressure <sup>(5)</sup>	dB(A)	68	69	69	70	70	70
Power supply	V/Ph/Hz	400/3+N/50	400/3+N/50	400/3+N/50	400/3+N/50	400/3+N/50	400/3+N/50

Performances are calculated with low fan speed and are referred to the following conditions:

(1) Without electric heater.

(2) Room temperature 30°C; water temperature 80/70°C, compressor OFF.

(3) Room temperature 30°C/80%; water temperature 30/35°C.

(4) Sound Power level according to ISO EN 3744 fan with available static pressure 50 Pa.

(5) Sound Pressure level measured at 1 mt from the unit in free field conditions according with ISO EN 3744, fan with available static pressure 50 Pa.

## PLANT SCHEME

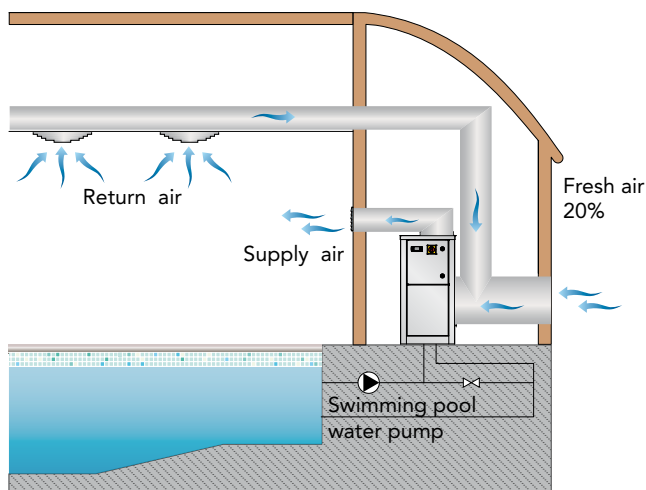

## OPERATION LIMITS

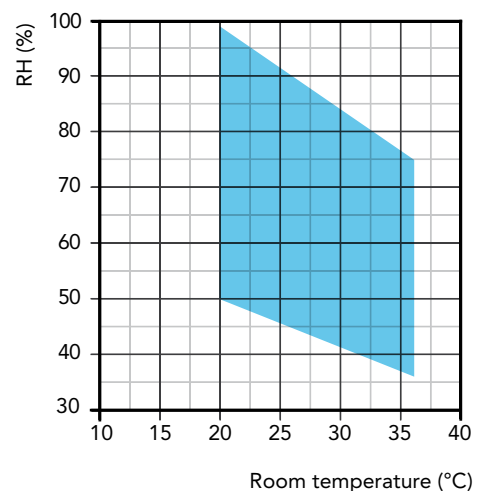

## COMPONENTS

### FRAME

All units are made from hot-galvanised thick sheet metal, painted with polyurethane powder enamel at 180°C to ensure the best resistance against the atmospheric agents. The frame is self-supporting with removable panels. All screws and rivets are in stainless steel. The colour of the units is RAL 9018.

### REFRIGERANT CIRCUIT

The refrigerant gas used in these units is R410A. The refrigerant circuit is made by using international primary brands components and according to ISO 97/23 concerning welding procedures.

The refrigerant circuit includes: sight glass, filter drier, thermal expansion valve with external equalizer, Schrader valves for maintenance and control, pressure safety device (according to PED regulation).

### COMPRESSOR

The compressors are Scroll type, with thermal overload protection by a klixon embedded in the motor winding. The compressor is mounted on rubber vibration dampers and it is supplied, standard, with sound-proof cover to reduce noise emission. The inspection is possible through the frontal panel of the unit that allows the maintenance of the compressor.

### CONDENSER AND EVAPORATOR

Condensers and evaporators are made of copper pipes and aluminium fins. All evaporators are painted with epoxy powders to prevent corrosion problem due to their use in aggressive environments. The diameter of the copper pipes is 3/8" and the thickness of the aluminium fins is 0,1 mm. The tubes are mechanically expanded into the aluminium fins to improve the heat exchange factor. The geometry of these heat exchangers guarantees a low air side pressure drop and then the use of low rotation (and low noise emission) fans. All units are supplied, standard, with a powder coated steel drip tray and all evaporators are supplied with a temperature sensor used as automatic defrost probe.

### FAN

The fans are made of galvanized steel, centrifugal type. It is statically and dynamically balanced and supplied.

The electric motors are directly connected to the fan; they are all at 2 speeds, with integrated thermal protection. The protection class of the motors is IP 54.

### AIR FILTER

It is made of synthetic filtering media, undulated type, without electro-static charge; they are all removable for differential disposal, ePM10 50% according to UNI EN ISO 16890:2017.

### MICROPROCESSOR

All units are supplied standard with microprocessor controls. The microprocessor controls the following functions: compressor timing, automatic defrost cycles, alarms.

An appropriate LCD display shows the operation mode of the unit, set point and alarms.

### ELECTRIC BOX

The electric switch board is made according to electromagnetic compatibility norms CEE 2014/35 and 2014/30. The accessibility to the board is possible after removing the front panel of the unit and the OFF positioning of the main switch. The following components are also standard installed: main switch, magnetic-thermal switches (as a protection fans and compressors), control circuit automatic breakers, compressor contactors, fan contactors. The terminal board is supplied with voltage free contacts for remote ON-OFF and general alarm.

### CONTROL AND PROTECTION DEVICES

All units are supplied with the following control and protection devices: antifreeze protection sensor, high pressure switch with manual reset, low pressure switch with automatic reset, high pressure safety valve, compressor thermal overload protection, fans thermal overload protection.

### TEST

All the units are fully assembled and wired at the factory, carefully evacuated and dried after leak tests under pressure and then charged with refrigerant R410A.

They are all fully operational tested before shipment. They all conform to European Directives and are individually marked with the CE label and provided with Conformity Declaration.

## ACCESSORY DESCRIPTIONS

### CANA - Delivery flange for channel connection

Press-folded rectangular flange for connection to the ducts and installed on the fan expulsion mouth.

### HYGR - Remote mechanical hygostat

To be installed on the wall, it is supplied with a regulation knob and working range from 30% to 100% with precision of 3%.

### HOEL - Electric heater

The electric heater kit is in aluminium and is used to integrate the unit heating capacity. The kit is composed of an on-off double safety thermostat without capacity steps.

### HOWA - Hot water coil

The heat exchanger is made of copper pipes and aluminium fins. The diameter of the copper pipes is 3/8" and the thickness of the aluminium fins is 0,1 mm. The tubes are mechanically expanded into the aluminium fins to improve the heat exchange factor.

### INSE - Serial interface card RS485

This interface card enables the controller to communicate with other devices using Modbus protocol.

### KIVM - 3 Way modulating valve kit

It is used to control the waterflow in the coil. The valve is directly controlled from the unit microprocessor.

### LS00 - Low noise version

This version includes the complete acoustic insulation of the unit (compressor + heat exchangers vanes) with compressor jackets and insulating material made with high density media and the interposition of heavy bitumen layer.

### PCRL - Remote control panel

This panel can be mounted up to 50m (maximum) from the unit and replicates all of the control functions. It is connected using a twin cable of 0.5 mm sq section.

### RGDD - Humidity and Temperature electronic probe sensor

Built-in Electronic temperature and humidity probe.

### RP01 - Partial heat recovery

The unit is fitted with a Coaxial type heat exchanger suitable for chlorinated water. The internal pipe is manufactured from Cupronickel with the external pipe being made from Copper. The chlorinated water flows within the internal pipe whilst the refrigerant gas passes through the gap between the internal and external pipes. The Cupronickel internal pipe is manufactured with a special profile that generates turbulent flow within the refrigerant.

ant gas thus increasing the heat exchange factor, the thermal efficiency and reducing the dimensions. The heat exchanger is designed to recover approx. 20% of the thermal capacity generated by the unit.

**V1CE - E.C. supply fan**

The supply fan is a high performance centrifugal type, double inlet forward curved blades, directly coupled to the electric motor. The fan wheel and the scroll are made from hot galvanised thick sheet metal, painted with polyurethane powders, to ensure the best resistance against aggressive environments. The electric motor is a high efficiency DC brushless type with exter-

nal rotor, to guarantee an ideal cooling of the windings and the absence of power lost due to pulleys and belt transmission. The fan is statically and dynamically balanced class 6,3 according to ISO1940. The electric motor has a separate electronic commutator (driver) and a speed modulation 0-10V, integrated PFC, burn out thermal protection (in case of considerable reduction of the power supply), protection degree IP54, serial interface card with modbus protocol RTU.

**ACCESSORIES**

SMA		270	350	450	550	750	950
A.C. fans ≤ 150 Pa		●	●	●	●	●	●
Supply flange	CANA	●	●	●	●	●	●
Thermostatic valve		●	●	●	●	●	●
Low noise version	LS00	●	●	●	●	●	●
Main switch		●	●	●	●	●	●
Humidity and Temperature electronic probe sensor	RGDD	○	○	○	○	○	○
Remote mechanical hygrostat	HYGR	○	○	○	○	○	○
Partial heat recovery Cu-Ni made	RP01	○	○	○	○	○	○
Hot water coil	HOWA	○	○	○	○	○	○
Modulating 3 way valve kit installed	KIVM	○	○	○	○	○	○
Electric heater kit 6 kW (400/3~/50)	HOEL	○	○	○	-	-	-
Electric heater kit 9 kW (400/3~/50)	HOEL	○	○	○	○	○	○
Electric heater kit 18 kW (400/3~/50)	HOEL	-	-	-	○	○	○
Stainless steel frame	INOX	○	○	○	○	○	○
Air filter with frame for ducted installation	FARC	○	○	○	○	○	○
Remote control Panel	PCRL	○	○	○	○	○	○
High efficiency E.C. fans ≤ 300 Pa	V1CE	○	○	○	○	○	○
Serial interface card RS485	INSE	○	○	○	○	○	○
Rubber vibration dampers	KAVG	○	○	○	○	○	○

● Standard, ○ Optional, - Not Available.

**POSSIBLE CONFIGURATIONS**

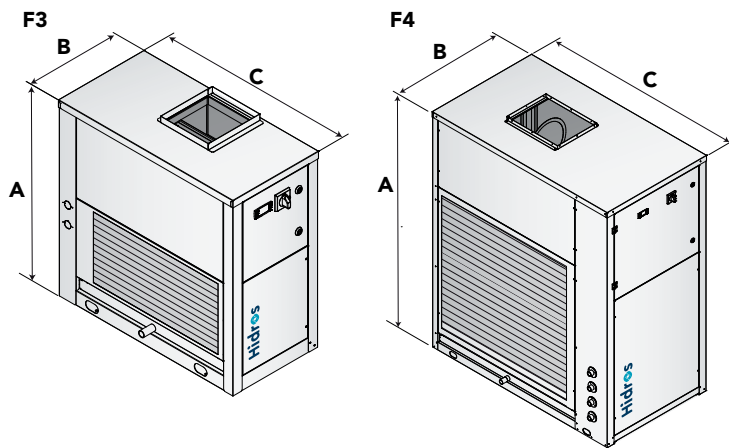
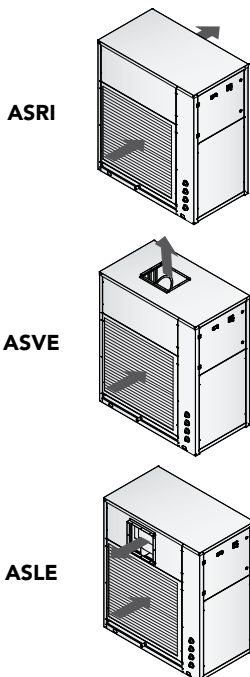

Mod.	Frame	A (mm)	B (mm)	C (mm)	kg
270	F3	1378	704	1154	207
350	F3	1378	704	1154	211
450	F3	1378	704	1154	215
550	F4	1750	854	1504	415
750	F4	1750	854	1504	423
950	F4	1750	854	1504	430

# SRH

## SWIMMING POOL DEHUMIDIFIERS

Dehumidifying capacity from 1130 l/24h to 3050 l/24h  
Air flow from 9500 m<sup>3</sup>/h to 25000 m<sup>3</sup>/h

---

R407C



---

Series SRH dehumidifier are expressly designed for use in swimming pools where humidity should be closely controlled in order to guarantee optimal comfort. These units are intended to be installed in a technical room close to the swimming pool. A centrifugal fan with high available static pressure allows unit connection to ductworks, both for air suction and discharge. This series comprises 6 basic models which cover a capacity range from 1150 to 3000 l/24h. All the units are fully assembled and wired at the factory.

### VERSIONS

**WZ Unit with heat recovery:** The unit is designed to have one refrigerant circuit condensed by air, the other one condensed both by water and air. If the unit is supplied with the advanced control panel it is possible to set operation priorities (air or water). In the SRH/WZ versions the heat recovery is designed to reject on the water about 50% of the total thermal load generated by the unit. When the heat recovery is activated, the supply air temperature of the unit is, basically, the same of the return air, so, in this case, the dehumidification is performed without air temperature increase. This operation mode is suitable during intermediate seasons when the humidity in the swimming pool has to be controlled but also the room air temperature overheating has to be avoided.

# TECHNICAL DATA

SRH		1100	1300	1500	1800	2200	3000
Moisture removed <sup>(1)</sup>	l/24h	1137,0	1289,0	1486,0	1868,0	2314,0	3061,0
Nominal input power <sup>(1)</sup>	kW	14,1	16,5	19,3	23,6	27,6	37,2
Maximum input power <sup>(2)</sup>	kW	21,7	23,0	30,5	35,9	42,0	61,0
Nominal input current <sup>(2)</sup>	A	37,4	37,6	49,8	58,4	81,2	98,8
Peak current	A	116,0	102,0	132,0	136,0	220,0	283,0
Hot water coil <sup>(2)</sup>	kW	72	88	94	112	125	155
Air flow	m <sup>3</sup> /h	9500	10500	13000	15000	17000	25000
Available static pressure	Pa	250	250	250	250	250	250
Refrigerant		R407C	R407C	R407C	R407C	R407C	R407C
Global warming potential (GWP)		1774	1774	1774	1774	1774	1774
Refrigerant charge	kg	13,0	14,0	22,0	25,0	25,0	37,5
Equivalent CO2 charge	t	23,06	24,836	39,03	44,35	44,35	66,52
Sound power <sup>(3)</sup>	dB(A)	93	94	96	96	97	98
Sound pressure <sup>(4)</sup>	dB(A)	77	78	79	79	80	80
Power supply	V/Ph/Hz	400/3+N/50	400/3+N/50	400/3+N/50	400/3+N/50	400/3+N/50	400/3+N/50

Performances are referred to the following conditions:

(1) Room temperature 30°C; relative humidity 80%.

(2) Standard available static pressure of the fans; without electrical heater.

(3) Sound Power level according to ISO EN 3744.

(4) Sound pressure level measured at 1 mt from the unit in free field conditions according to ISO EN 3744.

## OPERATION LIMITS

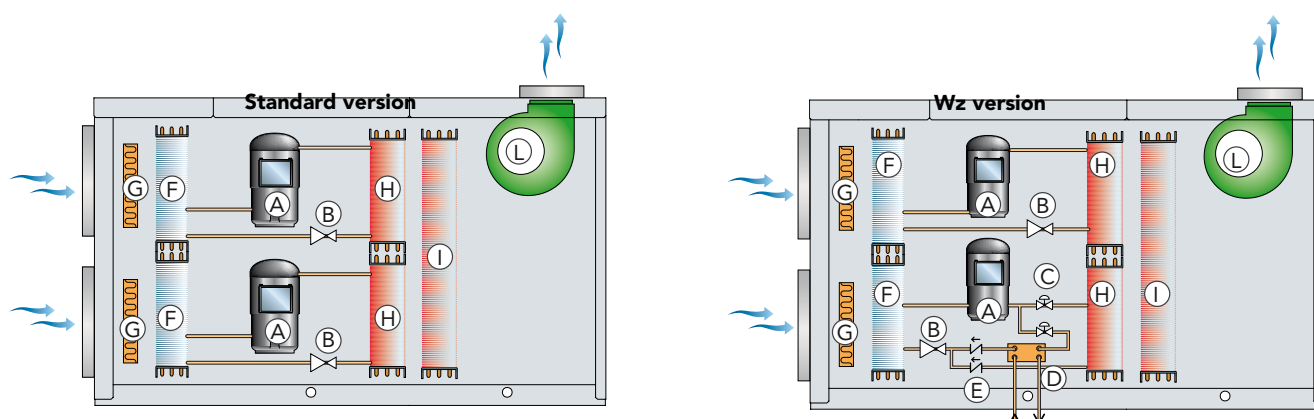
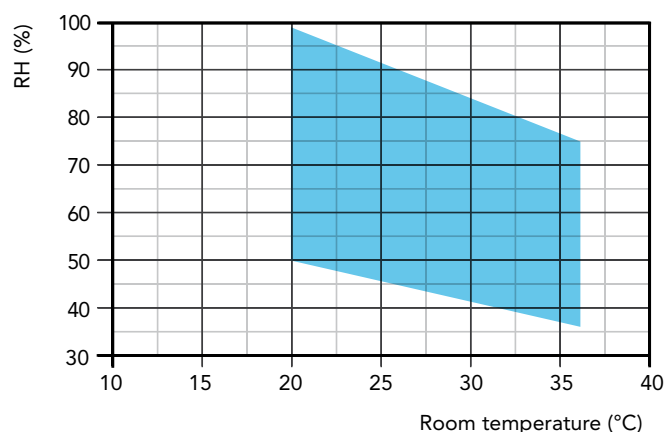

A	Compressor	F	Evaporator
B	Expansion valve	G	Air filter
C	Solenoid valve	H	Condenser
D	Heat recovery	I	Hot watercoil (accessory)
E	One way valve	L	Fan

## Plant scheme

The picture on the right shows a typical installation of the SRH units; Normally, the unit is installed in the technical room and ducted on both sides (supply and return). In many installations it is installed a fresh air duct designed for 15-20% airflow. Clearly, in this application also an exhaust fan has to be installed in order to avoid over pressure in the swimming pool. The water valve present in the heat recovery hydraulic circuit has to be set in order to guarantee the nominal water flow in the heat recovery.

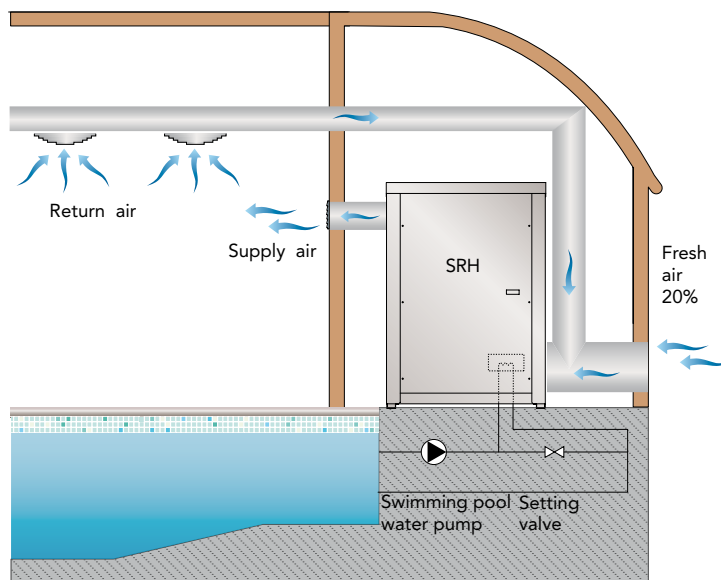

## COMPONENTS

### FRAME

All SRH units are made from hot-galvanised thick sheet metal, painted with polyurethane powder enamel at 180°C to ensure the best resistance against the atmospheric agents. The frame is self-supporting with removable panels. All screws and rivets are in stainless steel. The colour of the units is RAL 9018.

### REFRIGERANT CIRCUIT

The refrigerant gas used in these units is R407C. The refrigerant circuit is made by using international primary brands components and according to ISO 97/23 concerning welding procedures. All units are supplied with two circuits, each refrigerant circuit is totally independent from the other. Any incorrect operation of one circuit does not influence the other circuit. The refrigerant circuit includes: SRH liquid line manual shut-off valve, sight glass, filter drier, thermal expansion valve with external equalizer, Schrader valves for maintenance and control, pressure safety device (according to PED regulation). SRH/WZ.

These versions are supplied with one refrigerant circuit identical to the SRH version, the second circuit includes: one way valves, solenoid valves, liquid receiver, water heat recovery, liquid line shut-off valve, sight glass, filter drier, thermal expansion valve with external equalizer, Schrader valves for maintenance and control, pressure safety device.

### COMPRESSOR

The compressors are scroll type with crankcase heater and thermal overload protection by a klixon embedded in the motor winding. The compressors are mounted on rubber vibration dampers and they can be supplied with sound attenuation jacket to reduce the noise emission (option).

The compressor crankcase heater is always powered when the unit is in stand-by. The inspection on the compressors is possible only through the unit front panel.

### CONDENSER AND EVAPORATOR

Condensers and evaporators are made of copper pipes and aluminium fins. All evaporators are painted with epoxy powders to prevent corrosion problem due to their use in aggressive environments. The diameter of the copper pipes is 3/8" and the thickness of the aluminium fins is 0,1 mm. The tubes are mechanically expanded into the aluminium fins to improve the heat exchange factor. The geometry of these heat exchangers guarantees a low air side pressure drop and then the use of low rotation (and low noise emission) fans. All units are supplied,

standard, with a Stainless steel drip tray and all evaporators are supplied with a temperature sensor used as automatic defrost probe.

### FANS

The fans are made of galvanized steel, centrifugal type, double inlet with forward curved blades. They are statically and dynamically balanced and supplied complete of the safety fan guard according to EN 294. They are mounted on the unit frame by interposition of rubber vibration dampers. The electric motors are 4 poles (about 1500 rpm), three-phase power supply. The motors are connected to the fans by pulleys and belts. The protection class of the motors is IP 54.

### AIR FILTER

Supplied as standard with the unit, it is made of synthetic fibre filtering media, class coarse 60% according to UNI EN ISO 16890:2017.

### MICROPROCESSOR

All units can be supplied with 2 kind of controls:

Basic control: it manages the following features: antifreeze protection, compressor timing, compressor automatic starting sequence, defrost cycle, alarm reset, potential free contact for remote general alarm.

Advanced control: in addition to the basic control it manages a wider range of features as: setting the priority operation mode (SRH/WZ only), managing of the main and the secondary set points, display of the alarms with historical list, time band operation, integration with hot water coil and modulating valve. Upon request the advanced control can be connected to a BMS system for the remote control and management. The technical department is available to study, together with the customer, different solutions using MODBUS.

### ELECTRONIC PROBE TEMPERATURE-HUMIDITY

This sensor is supplied standard on the SRH/WZ versions supplied with advanced control.

It can be installed either in the room or in the return duct (to be specified before order) and allow the operation of the unit in the following modes:

- Dehumidification
- Heating ( by hot water coil)
- Dehumidification + heating
- Dehumidification + heat recovery



## ELECTRIC BOX

The electric switch board is made according to electromagnetic compatibility norms CEE 2014/35 and 2014/30. The accessibility to the board is possible after removing the front panel of the unit and the OFF positioning of the main switch. In all SRH units are installed, standard, the compressors sequence relay who disables the operation of the compressor in case the power supply phase sequence is not the correct one (scroll compressors in fact, can be damaged if they rotate reverse wise).

The following components are also standard installed: main switch, magnetic-thermal switches (as a protection fans and compressors), control circuit automatic breakers, compressor contactors, fan contactors. The terminal board is supplied with voltage free contacts for remote ON-OFF and general alarm.

## CONTROL AND PROTECTION DEVICES

All units are supplied with the following control and protection devices: antifreeze protection sensor, high pressure switch with manual reset, low pressure switch with automatic reset, high pressure safety valve, compressor thermal overload protection, fans thermal overload protection.

## ACCESSORIES

SRH		1100	1300	1500	1800	2200	3000
Advanced control panel (Humidity + temperature control)	CONT	●	●	●	●	●	●
Low noise version (LS)	LS00	○	○	○	○	○	○
Hot water coil	HOWA	○	○	○	○	○	○
On/Off 3 way valve kit installed	KIVM	○	○	○	○	○	○
Modulating 3 way valve kit installed	KIVM	○	○	○	○	○	○
Available static pressure 400 Pa	PM	○	○	○	○	○	○
Horizontal air discharge ( opposite side coils )	HORI	○	○	○	○	○	○
Manometers	MAML	○	○	○	○	○	○
Air filter with frame for ducted installation	FARC	○	○	○	○	○	○
	INSE	○	○	○	○	○	○

● Standard, ○ Optional, – Not Available.

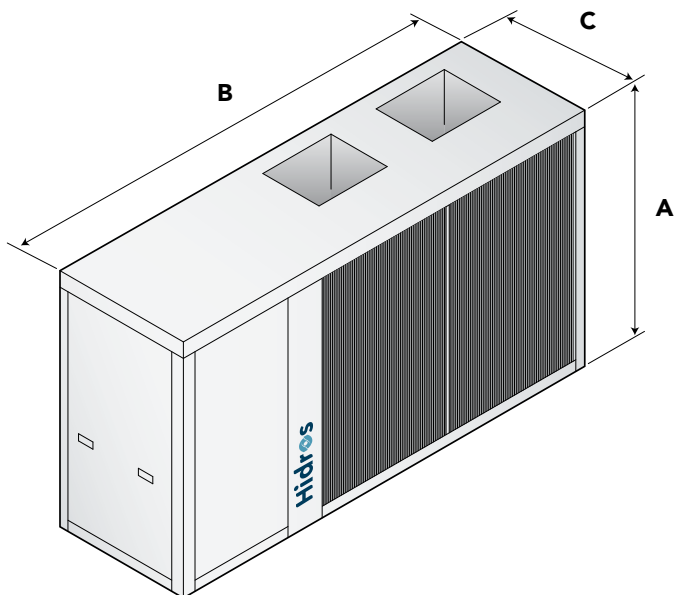

Mod.	A (mm)	B (mm)	C (mm)	kg
<b>1100</b>	1250	1870	850	580
<b>1300</b>	1250	1870	850	710
<b>1500</b>	1566	2608	1105	770
<b>1800</b>	1566	2608	1105	830
<b>2200</b>	1566	2608	1105	940
<b>3000</b>	1566	3608	1105	1290

# UTA - UTAZ

## ENERGY RECOVERY HIGH EFFICIENCY DEHUMIDIFIERS

Dehumidifying capacity from 132 l/24h to 910 l/24h  
Air flow from 1500 m<sup>3</sup>/h to 6000 m<sup>3</sup>/h

R410A



UTAZ (Outdoor Unit)

The energy recovery high efficiency dehumidifiers UTA range have been designed to grant the complete control of temperature, humidity, the energy recovery and the fresh air treatment in the covered swimming pools or in other applications with very high internal loads. The UTA units can operate in environments up to 36°C and are able to manage up to 30% of fresh air.

The range includes 7 models, which covers airflows range from 1500 to 6000 m<sup>3</sup>/h.

The use of double-passage-cross-flow energy recovery allows to increase up to 30% the dehumidification capacity in comparison to the traditional dehumidifiers.

The use of the double passage in the energy recovery, in fact, allows the free sensible pre-cooling of the air near to the saturation point, giving so the possibility to the unit to work, basically, in latent load.

## VERSIONS

- Z** Version with temperature control: These versions are supplied with a remote condenser and are used in those applications where it is necessary the simultaneous control of temperature and humidity: Dehumidification mode: the internal condenser is activated; the unit dehumidifies and heats up the room temperature; Cooling mode: the remote condenser is activated; the unit dehumidifies and cools down the room temperature.

## TECHNICAL DATA

UTA		015	020	028	035	042	052	060
Moisture removed <sup>(1)</sup>	l/24h	132,7	162,3	248,9	310,7	376,0	464,4	565,2
Moisture removed <sup>(2)</sup>	l/24h	223,0	290,9	444,8	552,2	587,5	746,4	907,5
Nominal input power <sup>(1)</sup>	kW	4,0	4,7	7,4	9,0	11,0	14,0	15,7
Maximum input power	kW	4,1	4,8	7,7	9,1	13,1	14,6	16,1
Maximum input current	A	19,1	22,8	22,4	24,6	30,5	32,5	34,5
Peak current	A	52,0	71,0	58,0	69,0	87,0	100,0	113,0
Hot water coil <sup>(3)</sup>	kW	18	23	28	33	53	64	70
Total air flow	m <sup>3</sup> /h	1500	2000	2800	3500	4200	5200	6000
Available static pressure	Pa	200	200	200	200	200	200	200
Fresh air flow	m <sup>3</sup> /h	450-600	600-800	845-1120	1050-1400	1260-1680	1560-2080	1800-2400
Refrigerant		R410A	R410A	R410A	R410A	R410A	R410A	R410A
Global warming potential (GWP)		2088	2088	2088	2088	2088	2088	2088
Refrigerant charge	kg	1,6	1,6	2,5	3,0	5,0	5,0	5,0
Equivalent CO2 charge	t	3,34	3,34	5,22	6,26	10,44	10,44	10,44
Sound power <sup>(4)</sup>	dB (A)	70	70	73	73	75	76	76
Sound pressure <sup>(5)</sup>	dB (A)	63	63	66	66	68	69	69
Compressors / Circuits	n°/n°	1 / 1	1 / 1	1 / 1	1 / 1	1 / 1	1 / 1	1 / 1
Power supply	V/Ph/Hz	400/3+N/50	400/3+N/50	400/3+N/50	400/3+N/50	400/3+N/50	400/3+N/50	400/3+N/50

Performances are referred to the following conditions:

(1) Room temperature 30°C; relative humidity 60%, fresh air 0%.

(2) Room temperature 30°C; relative humidity 60%, fresh air 30% (5°C 80%).

(3) Room temperature 30°C; water temperature 80/70°C, unit compressor in stand-by.

(4) Sound Power level according to ISO 9614, fan with available static pressure 200 Pa.

(5) Sound pressure level measured at 1 mt from the unit in free field conditions according to ISO 9614, fan with available static pressure 200 Pa.

UTAZ		015	020	028	035	042	052	060
Moisture removed <sup>(1)</sup>	l/24h	132,7	162,3	248,9	310,7	376,0	464,4	565,2
Moisture removed <sup>(2)</sup>	l/24h	223,0	290,9	444,8	552,2	587,5	746,4	907,5
Cooling capacity <sup>(3)</sup>	kW	3,5	4,7	6,5	8,3	10,0	12,2	14,0
Nominal input power <sup>(1)</sup>	kW	4,0	4,7	7,4	9,0	11,0	14,0	15,7
Maximum input power <sup>(1)</sup>	kW	4,1	4,8	7,7	9,1	13,1	14,6	16,1
Maximum input current	A	19,1	22,8	22,4	24,6	30,5	32,5	34,5
Peak current	A	52,0	71,0	58,0	69,0	87,0	100,0	113,0
Hot water coil <sup>(4)</sup>	kW	18	23	28	33	53	64	70
Total air flow	m <sup>3</sup> /h	1500	2000	2800	3500	4200	5200	6000
Available static pressure	Pa	200	200	200	200	200	200	200
Fresh air flow	m <sup>3</sup> /h	450-600	600-800	845-1120	1050-1400	1260-1680	1560-2080	1800-2400
Refrigerant		R410A	R410A	R410A	R410A	R410A	R410A	R410A
Global warming potential (GWP)		2088	2088	2088	2088	2088	2088	2088
Refrigerant charge	kg	2,0	2,0	3,0	3,0	5,0	5,0	5,0
Equivalent CO2 charge	t	4,17	4,17	6,26	6,26	10,44	10,44	10,44
Sound power <sup>(5)</sup>	dB (A)	70	70	73	73	75	76	76
Sound pressure <sup>(6)</sup>	dB (A)	63	63	66	66	68	69	69
Compressors / Circuits	n°/n°	1 / 1	1 / 1	1 / 1	1 / 1	1 / 1	1 / 1	1 / 1
Power supply	V/Ph/Hz	400/3+N/50	400/3+N/50	400/3+N/50	400/3+N/50	400/3+N/50	400/3+N/50	400/3+N/50

Performances are referred to the following conditions:

(1) Room temperature 30°C; relative humidity 60%, fresh air 0%.

(2) Room temperature 30°C; relative humidity 60%, fresh air 30% (-5°C 80%).

(3) Room temperature 30°C; relative humidity 60%, fresh air 0% (35°C-50%), net sensible cooling capacity in the room.

(4) Room temperature 30°C; water temperature 80/70°C, unit compressor in stand-by.

(5) Sound Power level according to ISO 9614, fan with available static pressure 200 Pa.

(6) Sound pressure level measured at 1 mt from the unit in free field conditions according to ISO 9614, fan with available static pressure 200 Pa.

**Operation principle**

The hot and humid return airflow, moved by the fan (G), passes in the return filter (A), then across the first side of the energy recovery (B) where, crossing the cold air present on the other side, leaves part of its enthalpy. At this point part of the treated air (from 0% to 30%) is removed by the exhaust fan (C), while the remaining part passes across the cold evaporating coil (D) where it is dried at the required level.

After the evaporator the cold and dried airflow is mixed with fresh air (from 0% to 30%) entered through the fresh air damper (E) and returned into the energy recovery for the second passage where, crossing the hot air present on the other side, it is warmed up. The airflow then passes across the condensing coil (F) where it is post heated and finally sent into the swimming pool. In case the air discharge temperature is still too cold, the hot water temperature coil H ( accessory) will provide to increase it up to the required level.

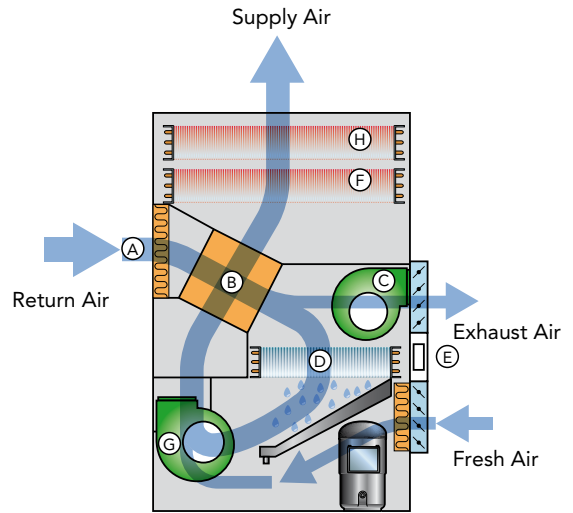

**COMPONENTS**

**FRAME**

All UTA units are made from hot-galvanised thick sheet metal, painted with polyurethane powder enamel at 180°C to ensure the best resistance against the atmospheric agents and to operate in aggressive environments. The frame is self-supporting with removable panels. A stainless steel drip tray is installed on all units. The colour of the units is RAL 7035.

**REFRIGERANT CIRCUIT**

The refrigerant circuit is made by using international primary brands components and according to ISO 97/23 concerning welding procedures. The refrigerant gas used in these units is R410A. The refrigerant circuit includes: sight glass, filter drier, thermal expansion valve with external equalizer, liquid line manual shut-off valve, Schrader valves for maintenance and control, pressure safety device (according to PED regulation).

**COMPRESSOR**

The compressor is scroll type, with crankcase heater and thermal overload protection by a klixon embedded in the motor winding. The compressor is mounted on rubber vibration dampers and, upon request, can be supplied with sound-proof cover to reduce noise emission (accessory). The crankcase heater, when present, is always powered when the compressor is in stand-by.

The inspection is possible through the frontal panel of the unit that allows the maintenance of the compressor.

**CONDENSER AND EVAPORATOR**

Condensers and evaporators are made of copper pipes and aluminium fins. All coils are painted with epoxy powders to prevent corrosion problem due to their use in aggressive environments. The diameter of the copper pipes is 3/8" and the thickness of the aluminium fins is 0,1 mm. The tubes are mechanically expanded into the aluminium fins to improve the heat exchange factor. The geometry of these condensers guarantees a low air side pressure drop and then the use of low rotation (and low noise emission) fans. All units are supplied, standard, with a stainless steel drip tray and all evaporators are supplied with a temperature sensor used as automatic defrost probe.

**HEAT RECOVERY**

The heat recovery is cross flow heat exchanger type, with painted aluminium plates; painted galvanised steel frame with additional tightening of the heat exchange pack, in order to operate in aggressive environments; it has a low pressure drop value and it is always supplied with stainless steel drip tray.

**HOT WATER COIL**

The hot water coil is made of copper pipes and aluminium fins.

**OPERATION LIMITS**

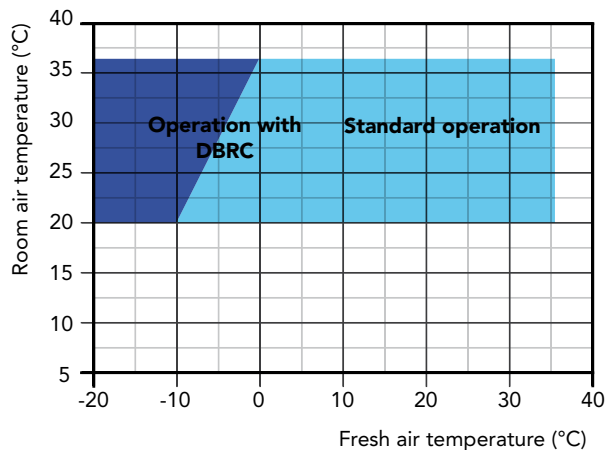
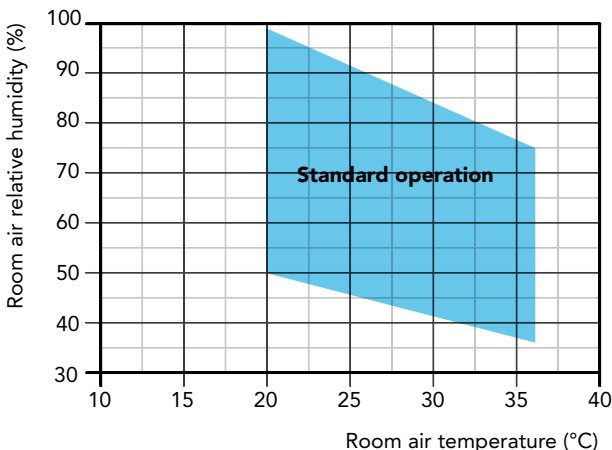

## PLANT SCHEME

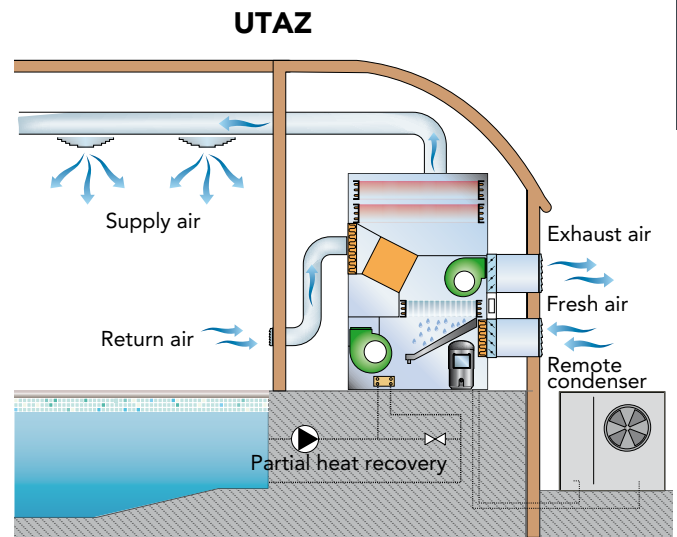
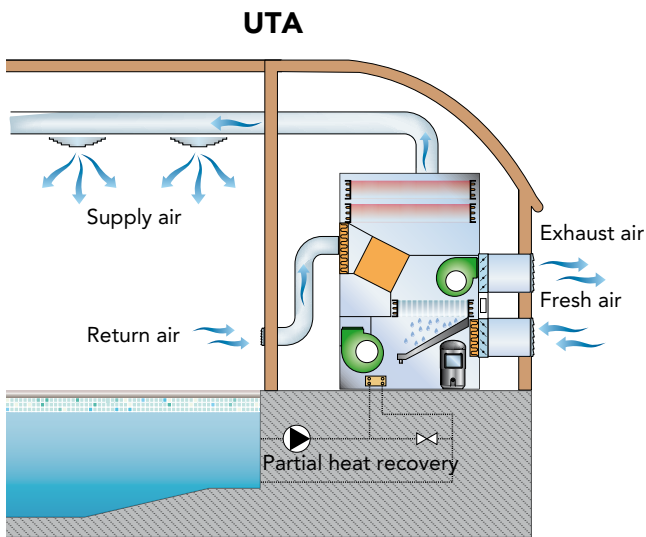

The diameter of the copper pipes is 3/8" and the thickness of the aluminium fins is 0,1 mm. The tubes are mechanically expanded into the aluminium fins to improve the heat exchange factor. All coils are supplied with a built-in 3 way modulating valve, directly managed by the microprocessor of the unit.

### E.C. SUPPLY FAN

The supply fan is a high performance centrifugal type, double inlet forward curved blades, directly coupled to the electric motor. The fan wheel and the scroll are made from hot galvanised thick sheet metal, painted with polyurethane powders, to ensure the best resistance against aggressive environments. The electric motor is a high efficiency DC brushless type with external rotor, to guarantee an ideal cooling of the windings and the absence of power lost due to pulleys and belt transmission. The fan is statically and dynamically balanced class 6,3 according to ISO1940. The electric motor has a separate electronic commutator (driver) and a speed modulation 0-10V, integrated PFC, burn out thermal protection (in case of considerable reduction of the power supply), protection degree IP54, serial interface card with modbus protocol RTU.

### E.C. EXHAUST FAN

The exhaust fan is a high performance centrifugal type, double inlet forward curved blades, directly coupled to the electric motor. The fan wheel and the scroll are made from hot galvanised thick sheet metal, painted with polyurethane powders, to ensure the best resistance against aggressive environments. The electric motor is a high efficiency DC brushless type with external rotor, to guarantee an ideal cooling of the windings and the absence of power lost due to pulleys and belt transmission. The fan is statically and dynamically balanced class 6,3 according to ISO1940. The electric motor has a separate electronic commutator (driver) and a speed modulation 0-10V, integrated PFC, burn out thermal protection (in case of considerable reduction of the power supply), protection degree IP54, serial interface card with modbus protocol RTU.

### EXHAUST AND FRESH AIR DAMPERS

The exhaust and fresh air dampers are made of aluminium frame and fins, distance between the fins 150 mm. The bushes are in nylon; exhaust and fresh air dampers are connected each other and supplied already with servomotor managed by the microprocessor of the unit.

### AIR FILTER

It's supplied standard with the unit. It's made of filtering material in synthetic fibre without electrostatic charge. It can be removed for differential disposal, ePM10 50% according to UNI EN ISO 16890:2017.

### MICROPROCESSOR

All UTA units are supplied standard with microprocessor controls. The microprocessor controls the following functions: compressor timing, automatic defrost cycles, the management of fresh and exhaust air, post heating valve and alarms. An appropriate LCD display shows the operation mode of the unit, set point and alarms.

### BUILT-IN TEMPERATURE/HUMIDITY ELECTRONIC PROBE

It is installed, standard, on all UTA units. It is installed on the return air side and allows the unit to operate in dehumidification or heating depending on the required parameters. The electronic probe allows the showing of temperature and humidity values with an operating range from 0-50°C, humidity from 10-90%.

### ELECTRIC BOX

The electric switch board is made according to electromagnetic compatibility norms CEE 2014/35 and 2014/30. The accessibility to the board is possible after removing the front panel of the unit and the OFF positioning of the main switch. In all UTA units are installed, standard, the compressors sequence relay which disables the operation of the compressor in case the power supply phase sequence is not the correct one (scroll compressors in fact, can be damaged if they rotate reverse wise). The following components are also standard installed: main switch, magnetic-thermal switches (as a protection of pumps and fans), compressors fuses, control circuit automatic breakers, compressor contactors, fan contactors, pump contactors. The terminal board is also supplied with voltage free contacts for remote ON-OFF.

### CONTROL AND PROTECTION DEVICES

All units are supplied with the following control and protection devices: defrost thermostat, which signals to the microprocessor control that a defrost cycle is needed and controls its termination, high pressure switch with manual reset, low pressure switch with automatic reset, high pressure safety valve, compressor thermal overload protection, fans thermal overload protection.

## ACCESSORY DESCRIPTIONS

### DBRC - Low ambient temperature device

The low ambient temperature device is used when the fresh air temperature is lower than -5°C and allows the correct operation of the unit with very low ambient temperatures. The device is made of a heat recovery composed by 2 water+ glycol coils connected with a water pump. The upper coil recovers the thermal load of the exhaust air, the mixture (glycol +water ) in the coil is warmed up, then it is moved to the lower coil where the thermal load is transferred to the fresh air that is pre-heat before entering in the unit. The use of this device allows two advantages:- An additional heat recovery on the exhaust air increasing then the unit energy efficiency,- The fresh air inlet is suitable for the correct operation of the internal components.

The device is managed by the unit microprocessor and it is factory set; The operation mode is the following: When the fresh air sensor measures a temperature lower than -5°C it is activated the water pump so the heat recovery function. The device is in operation until the fresh air temperature raises above the minimum set point temperature (set in the microprocessor). The microprocessor, with a compared measures of temperature and humidity sensors, provides to switch off the compressor in case the fresh air conditions are suitable to guarantee the required indoor conditions. In this way it is reduced the energy consumption of the unit that operates in FREE COOLING MODE.

### PCRL - Remote control panel

This panel can be mounted up to 50m (maximum) from the unit and replicates all of the control functions.

### RGDD - Humidity and Temperature electronic probe sensor

Built-in Electronic temperature and humidity probe.

### RP01 - Partial heat recovery

The unit is fitted with a Coaxial type heat exchanger suitable for chlorinated water. The internal pipe is manufactured from Cupronickel with the external pipe being made from Copper. The chlorinated water flows within the internal pipe whilst the refrigerant gas passes through the gap between the internal and external pipes.

The Cupronickel internal pipe is manufactured with a special profile that generates turbulent flow within the refrigerant gas thus increasing the heat exchange factor, the thermal efficiency and reducing the dimensions. The heat exchanger is designed to recover approx. 20% of the thermal capacity generated by the unit.

### INSE - Serial interface card RS485

This interface card enables the controller to communicate with other devices using Modbus protocol.

## POSSIBLE CONFIGURATIONS

**ASVR**

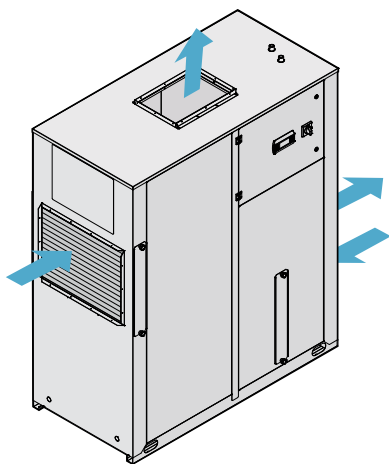

Right version  
vertical air flow

**ASLR**

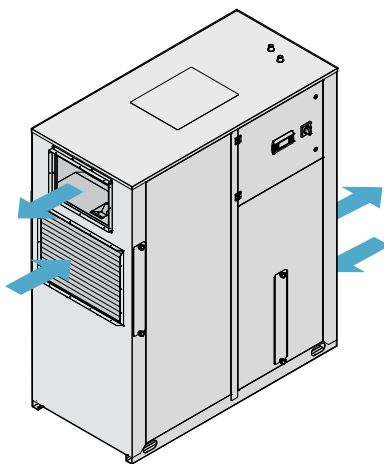

Right version  
left air flow

**ASRR**

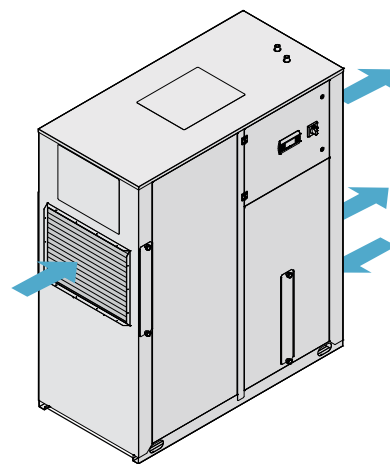

Right version  
right air flow

## ACCESSORIES

UTA		015	020	028	035	042	052	060
Partial heat recovery Cu-Ni made	RP01	○	○	○	○	○	○	○
Low ambient temperature device with heat recovery	DBRC	○	○	○	○	○	○	○
Remote control Panel	PCRL	○	○	○	○	○	○	○
High efficiency E.C. fans $\leq 300$ Pa	VECE	●	●	●	●	●	●	●
Serial interface card RS485	INSE	○	○	○	○	○	○	○

● Standard, ○ Optional, – Not Available.

UTAZ		015	020	028	035	042	052	060
Partial heat recovery Cu-Ni made	RP01	○	○	○	○	○	○	○
Low ambient temperature device with heat recovery	DBRC	–	–	–	–	–	–	–
Remote control Panel	PCRL	○	○	○	○	○	○	○
High efficiency E.C. fans $\leq 300$ Pa	VECE	●	●	●	●	●	●	●
Outdoor unit with condensation pressure control	CN	●	●	●	●	●	●	●
Serial interface card RS485	INSE	○	○	○	○	○	○	○

● Standard, ○ Optional, – Not Available.

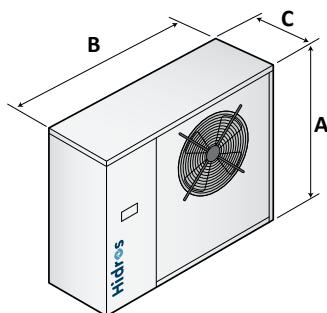
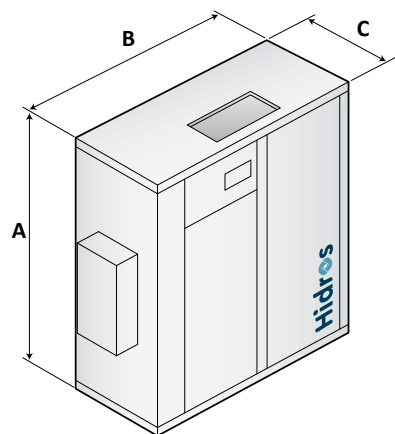

UTA - UTAZ (indoor unit)

Mod.	A (mm)	B (mm)	C (mm)	kg
015	1770	1000	640	290
020	1770	1000	640	305
028	1850	1500	750	400
035	1850	1500	750	420
042	1950	1950	1250	570
052	1950	1950	1250	590
060	1950	1950	1250	620

Outdoor unit (UTAZ only)

Mod.	A (mm)	B (mm)	C (mm)	kg
015	989	1103	380	80
020	989	1103	380	80
028	1324	1203	423	92
035	1324	1203	423	92
042	1324	1203	423	92
052	1423	1453	473	130
060	1423	1453	473	130

ASVL

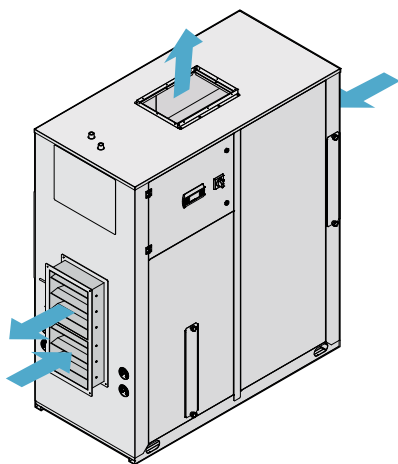

Left version  
vertical air flow

ASLL

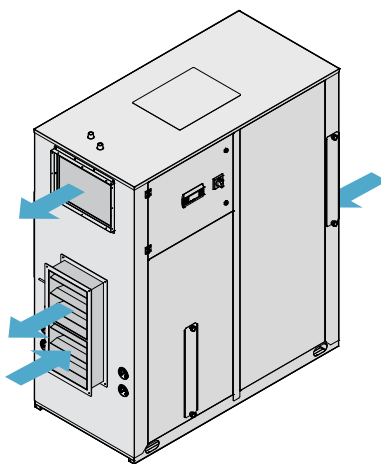

Left version  
left air flow

ASRL

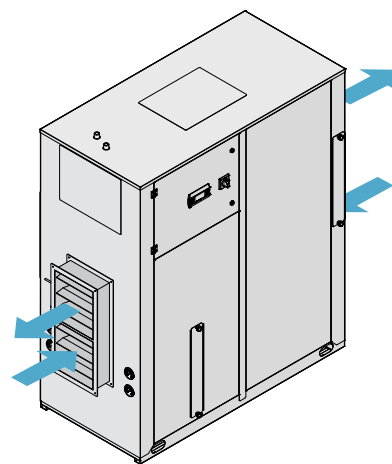

Left version  
right air flow

Cooling capacity from 20 kW to 390 kW



LDA water chillers are efficient, low-noise products designed for medium to large applications.

They are suitable for generating chilled water at temperatures in the region of 7°C, commonly used in applications with fan coils and/or air handling units.

The use of tandem scroll compressors results in high efficiencies (especially at part loads) and low noise levels, making them suitable for use in many applications.

Differing versions and a wide range of accessories, enable the optimal solution to be selected.

### VERSIONS

- CO** Cooling only.
- SA** Standard efficiency, AC fans. Only for the non-EU market
- SE** Standard efficiency, EC fans.
- HA** High efficiency, AC fans.
- HE** High efficiency, EC fans.
- LS** Low noise.
- XL** Extra low noise.
- BT** Cooling only for low user water temperature.
- CN** Condensing unit version.



## TECHNICAL DATA

HA/LS/CO		242	292	412	432	492	602	702	802	902	1002	1202	1402
Cooling capacity (EN14511) <sup>(1)</sup> kW		19,6	26,7	32,3	42,8	46,8	55,0	61,5	68,4	82,6	93,5	104,5	121,4
Total input power (EN14511) <sup>(1)</sup> kW		6,3	8,6	10,3	13,8	15,0	17,1	19,6	22,0	26,2	30,0	33,6	38,1
EER (EN14511) <sup>(1)</sup>	W/W	3,10	3,11	3,13	3,11	3,11	3,22	3,13	3,11	3,15	3,12	3,11	3,19
SEER <sup>(2)</sup>	kWh/kWh	4,11	4,20	4,19	4,11	4,12	4,20	4,19	4,19	4,14	4,13	4,12	4,13
$\eta_{s,c}$ <sup>(2)</sup>	%	161	161	164	162	162	165	165	165	163	162	162	162
Sound power <sup>(3)</sup>	dB (A)	75	75	75	75	77	77	77	78	83	84	85	87
Sound pressure <sup>(4)</sup>	dB (A)	43	43	43	43	45	45	45	46	51	52	53	55
Water tank volume	l	100	100	100	100	100	300	300	300	300	300	300	500
HE/LS/CO		242	292	412	432	492	602	702	802	902	1002	1202	1402
Cooling capacity (EN14511) <sup>(1)</sup> kW		19,7	26,7	32,0	42,8	46,6	55	61,6	68,6	82,6	93,8	105	121,6
Total input power (EN14511) <sup>(1)</sup> kW		6,2	8,4	10,0	13,6	14,8	16,9	19,3	21,8	25,4	29,6	33,2	36,8
EER (EN14511) <sup>(1)</sup>	W/W	3,16	3,18	3,19	3,15	3,14	3,25	3,19	3,15	3,25	3,17	3,16	3,30
SEER <sup>(2)</sup>	kWh/kWh	4,20	4,25	4,35	4,29	4,26	4,39	4,31	4,24	4,37	4,34	4,25	4,40
$\eta_{s,c}$ <sup>(2)</sup>	%	165	167	171	168	167	173	169	167	172	171	167	173
Sound power <sup>(3)</sup>	dB (A)	71	73	73	75	77	77	77	78	81	84	85	86
Sound pressure <sup>(4)</sup>	dB (A)	39	41	41	43	45	45	45	46	49	52	53	54
Power supply	V/Ph/Hz	400/3+N/50	400/3+N/50	400/3/50	400/3/50	400/3/50	400/3/50	400/3/50	400/3/50	400/3/50	400/3/50	400/3/50	400/3/50
Compressors / Circuits	n° / n°	2 / 1	2 / 1	2 / 1	2 / 1	2 / 1	2 / 1	2 / 1	2 / 1	2 / 1	2 / 1	2 / 1	2 / 1
Fans	n°	1	1	2	2	2	2	2	2	2	2	2	3
Refrigerant		R410A	R410A	R410A	R410A	R410A	R410A	R410A	R410A	R410A	R410A	R410A	R410A
Refrigerant charge	kg	6,5	6,5	6,5	10,0	8,5	8,5	14,5	14,5	19,0	19,0	20,0	28,0
Global warming potential (GWP)		2088	2088	2088	2088	2088	2088	2088	2088	2088	2088	2088	2088
Equivalent CO <sub>2</sub> charge	t	13,57	13,57	13,57	20,88	17,74	17,74	30,27	30,27	39,67	39,67	41,76	58,46
Water tank volume	l	100	100	100	100	100	300	300	300	300	300	300	500

HA/LS/CO		1602	1802	2002	2302	2502	2504	3004	3204	3504	4004	4504
Cooling capacity (EN14511) <sup>(1)</sup> kW		133,3	151,6	168,9	195,0	214,5	208,8	242,5	266,0	301,1	340,5	390,0
Total input power (EN14511) <sup>(1)</sup> kW		42,9	48,7	54,3	62,7	68,8	67,1	77,5	85,3	96,8	109,5	125,4
EER (EN14511) <sup>(1)</sup>	W/W	3,11	3,11	3,11	3,11	3,12	3,11	3,13	3,12	3,11	3,11	3,11
SEER <sup>(2)</sup>	kWh/kWh	4,19	4,13	4,17	4,18	4,13	4,12	4,13	4,15	4,17	4,19	4,18
$\eta_{s,c}$ <sup>(2)</sup>	%	165	162	164	164	162	162	162	163	164	165	164
Sound power <sup>(3)</sup>	dB (A)	88	88	88	89	91	89	90	91	91	91	93
Sound pressure <sup>(4)</sup>	dB (A)	56	56	56	57	59	57	58	59	59	59	61
Water tank volume	l	500	500	5000	500	1000	1000	1000	1000	1000	1000	1000
HE/LS/CO		1602	1802	2002	2302	2502	2504	3004	3204	3504	4004	4504
Cooling capacity (EN14511) <sup>(1)</sup> kW		133,3	152,1	169,3	195,6	215,1	210,3	246,8	267,7	303,2	345,3	390
Total input power (EN14511) <sup>(1)</sup> kW		41,8	48,1	53,6	62,7	68,3	66,3	76,2	85,0	95,3	108,2	123,8
EER (EN14511) <sup>(1)</sup>	W/W	3,19	3,16	3,16	3,12	3,15	3,17	3,24	3,15	3,18	3,19	3,15
SEER <sup>(2)</sup>	kWh/kWh	4,42	4,41	4,31	4,40	4,28	4,25	4,36	4,32	4,41	4,28	4,43
$\eta_{s,c}$ <sup>(2)</sup>	%	174	175	169	173	168	167	171	170	173	168	174
Sound power <sup>(3)</sup>	dB (A)	87	88	88	89	91	88	89	90	91	91	93
Sound pressure <sup>(4)</sup>	dB (A)	55	56	56	57	59	56	57	58	59	59	61
Power supply	V/Ph/Hz	400/3/50	400/3/50	400/3/50	400/3/50	400/3/50	400/3/50	400/3/50	400/3/50	400/3/50	400/3/50	400/3/50
Compressors / Circuits	n° / n°	2 / 1	2 / 1	2 / 1	2 / 1	2 / 1	4 / 2	4 / 2	4 / 2	4 / 2	4 / 2	4 / 2
Fans	n°	3	3	3	3	3	4	6	6	6	6	8
Refrigerant		R410A	R410A	R410A	R410A	R410A	R410A	R410A	R410A	R410A	R410A	R410A
Refrigerant charge	kg	30,0	30,0	30,0	30,0	40,0	40,0	50,0	60,0	50,0	60,0	90,0
Global warming potential (GWP)		2088	2088	2088	2088	2088	2088	2088	2088	2088	2088	2088
Equivalent CO <sub>2</sub> charge	t	62,64	62,64	62,64	62,64	83,52	83,52	104,40	152,28	104,40	152,28	187,92
Water tank volume	l	500	500	5000	500	1000	1000	1000	1000	1000	1000	1000

Performances are referred to the following conditions:

(1) Cooling: ambient air temperature 35°C, evaporator water temperature in/out 12/7 °C.

(2) In accordance with (EU) 2016/2281 and relative norms part of this.

(3) Sound power level in accordance with ISO 3744.

(4) Sound pressure level at 10 mt from the unit in free field conditions in accordance with ISO 3744.

SE/XL/CO		252	302	402	432	492	592	702	802	1002	1202	1402
Cooling capacity (EN14511) <sup>(1)</sup> kW		18,5	25,4	29,4	39,7	44,4	50,6	55,8	63,0	85,2	92,7	105,2
Total input power (EN14511) <sup>(1)</sup> kW		6,5	9,1	10,4	13,9	15,0	18,3	21,1	22,9	31,3	36,8	40,9
EER (EN14511) <sup>(1)</sup>	W/W	2,84	2,81	2,82	2,87	2,96	2,77	2,64	2,75	2,72	2,52	2,57
SEER <sup>(2)</sup>	kWh/kWh	4,14	4,12	4,14	4,11	4,12	4,15	4,11	4,12	4,13	4,11	4,15
$\eta_{s,c}$ <sup>(2)</sup>	%	163	162	163	161	162	163	162	162	162	162	163
Sound power <sup>(3)</sup>	dB (A)	68	69	69	71	75	75	75	76	80	82	83
Sound pressure <sup>(4)</sup>	dB (A)	36	37	37	39	43	43	43	44	48	50	51
Power supply	V/Ph/Hz	400/3+N/50 400/3+N/50 400/3+N/50 400/3/50 400/3/50 400/3/50 400/3/50 400/3/50 400/3/50 400/3/50 400/3/50 400/3/50										
Compressors / Circuits	n° / n°	2 / 1	2 / 1	2 / 1	2 / 1	2 / 1	2 / 1	2 / 1	2 / 1	2 / 1	2 / 1	2 / 1
Fans	n°	2	2	2	2	2	2	2	2	3	3	3
Refrigerant		R410A	R410A	R410A	R410A	R410A	R410A	R410A	R410A	R410A	R410A	R410A
Refrigerant charge	kg	6,5	6,5	6,5	8,5	8,5	8,5	8,5	14,5	17,0	17,0	17,0
Global warming potential (GWP)		2088	2088	2088	2088	2088	2088	2088	2088	2088	2088	2088
Equivalent CO <sub>2</sub> charge	t	13,57	13,57	13,57	17,74	17,74	17,74	17,74	30,27	35,49	35,49	35,49
Water tank volume	l	100	100	100	100	100	100	300	300	500	500	500

SE/XL/CO		1602	1802	2002	2302	2502	2504	3004	3204	3504	4004	4504	5004
Cooling capacity (EN14511) <sup>(1)</sup> kW		118,0	135,5	148,2	175,9	198,0	193,1	210,6	232,2	286,8	314,4	355,2	395,0
Total input power (EN14511) <sup>(1)</sup> kW		44,9	51,5	59,8	65,6	72,8	71,5	83,2	92,5	99,9	115,2	131,6	144,2
EER (EN14511) <sup>(1)</sup>	W/W	2,63	2,63	2,48	2,68	2,72	2,70	2,53	2,51	2,87	2,73	2,70	2,74
SEER <sup>(2)</sup>	kWh/kWh	4,12	4,14	4,12	4,15	4,13	4,13	4,15	4,12	4,15	4,14	4,13	4,15
$\eta_{s,c}$ <sup>(2)</sup>	%	162	163	162	163	162	162	163	162	163	163	162	163
Sound power <sup>(3)</sup>	dB (A)	85	85	85	87	89	85	87	88	88	88	90	91
Sound pressure <sup>(4)</sup>	dB (A)	53	53	53	55	57	53	55	56	56	56	58	59
Power supply	V/Ph/Hz	400/3/50 400/3/50 400/3/50 400/3/50 400/3/50 400/3/50 400/3/50 400/3/50 400/3/50 400/3/50 400/3/50 400/3/50 400/3/50											
Compressors / Circuits	n° / n°	2 / 1	2 / 1	2 / 1	2 / 1	2 / 1	4 / 2	4 / 2	4 / 2	4 / 2	4 / 2	4 / 2	4 / 2
Fans	n°	4	4	4	3	4	4	4	4	6	6	6	8
Refrigerant		R410A	R410A	R410A	R410A	R410A	R410A	R410A	R410A	R410A	R410A	R410A	R410A
Refrigerant charge	kg	18,0	30,0	25,0	33,0	33,0	40,0	40,0	50,0	60,0	70,0	90,0	90,0
Global warming potential (GWP)		2088	2088	2088	2088	2088	2088	2088	2088	2088	2088	2088	2088
Equivalent CO <sub>2</sub> charge	t	37,58	62,64	52,20	69,90	69,90	83,52	83,52	104,40	152,28	146,16	187,92	187,92
Water tank volume	l	500	500	500	500	500	500	500	500	1000	1000	1000	1000

Performances are referred to the following conditions:

- (1) Cooling: ambient air temperature 35°C, evaporator water temperature in/out 12/7 °C.  
(2) In accordance with (EU) 2016/2281 and relative norms part of this

- (3) Sound power level in accordance with ISO 3744.

- (4) Sound pressure level at 10 mt from the unit in free field conditions in accordance with ISO 3744.

HA/XL/CO		252	302	412	432	492	602	702	802	902	1002	1202	1402
Cooling capacity (EN14511) <sup>(1)</sup> kW		20,5	27,0	31,9	42,6	46,1	54,0	61,2	68,1	80,7	91,2	103,2	118,8
Total input power (EN14511) <sup>(1)</sup> kW		6,6	8,7	10,2	13,7	14,9	17,4	19,6	22,0	25,4	29,4	33,3	36,9
EER (EN14511) <sup>(1)</sup>	W/W	3,11	3,10	3,14	3,11	3,10	3,11	3,12	3,10	3,18	3,10	3,10	3,22
SEER <sup>(2)</sup>	kWh/kWh	4,14	4,11	4,15	4,13	4,11	4,16	4,15	4,15	4,16	4,17	4,16	4,20
$\eta_{s,c}$ <sup>(2)</sup>	%	162	161	163	162	161	163	163	163	163	164	163	165
Sound power <sup>(3)</sup>	dB (A)	70	70	70	70	72	72	72	73	75	77	78	80
Sound pressure <sup>(4)</sup>	dB (A)	38	38	38	38	40	40	40	41	43	45	46	48
Water tank volume	l	100	100	100	100	100	300	300	300	300	300	300	500
HE/XL/CO		252	302	412	432	492	602	702	802	902	1002	1202	1402
Cooling capacity (EN14511) <sup>(1)</sup> kW		20,5	27,0	31,4	42,6	46,1	54,0	61,2	68,1	80,7	91,2	103,2	118,8
Total input power (EN14511) <sup>(1)</sup> kW		6,6	8,7	10,1	13,7	14,8	17,2	19,6	21,9	25,4	29,2	33,2	36,9
EER (EN14511) <sup>(1)</sup>	W/W	3,12	3,11	3,12	3,11	3,11	3,14	3,13	3,11	3,18	3,12	3,11	3,22
SEER <sup>(2)</sup>	kWh/kWh	4,35	4,32	4,44	4,25	4,30	4,35	4,30	4,25	4,40	4,43	4,30	4,50
$\eta_{s,c}$ <sup>(2)</sup>	%	171	170	175	167	169	171	169	167	173	174	169	177
Sound power <sup>(3)</sup>	dB (A)	64	65	68	70	72	72	72	73	75	77	78	80
Sound pressure <sup>(4)</sup>	dB (A)	32	33	36	38	40	40	40	41	43	45	46	48
Power supply	V/Ph/Hz	400/3+N/50	400/3+N/50	400/3/50	400/3/50	400/3/50	400/3/50	400/3/50	400/3/50	400/3/50	400/3/50	400/3/50	400/3/50
Compressors / Circuits	n° / n°	2 / 1	2 / 1	2 / 1	2 / 1	2 / 1	2 / 1	2 / 1	2 / 1	2 / 1	2 / 1	2 / 1	2 / 1
Fans	n°	2	2	2	2	2	2	2	2	2	2	2	3
Refrigerant		R410A	R410A	R410A	R410A	R410A	R410A	R410A	R410A	R410A	R410A	R410A	R410A
Refrigerant charge	kg	6,5	6,5	6,5	10,0	8,5	8,5	14,5	14,5	19,0	19,0	20,0	28,0
Global warming potential (GWP)		2088	2088	2088	2088	2088	2088	2088	2088	2088	2088	2088	2088
Equivalent CO <sub>2</sub> charge	t	13,57	13,57	13,57	20,88	17,74	17,74	30,27	30,27	39,67	39,67	41,76	58,46
Water tank volume	l	100	100	100	100	100	300	300	300	300	300	300	500

HA/XL/CO		1602	1802	2002	2302	2502	2504	3004	3204	3504	4004	4504
Cooling capacity (EN14511) <sup>(1)</sup> kW		130,1	150,1	166,8	189,1	211,0	208,5	236,0	264,0	297,8	337,4	383,5
Total input power (EN14511) <sup>(1)</sup> kW		42,0	48,1	53,8	60,8	67,8	67,3	75,6	84,9	95,8	108,5	123,7
EER (EN14511) <sup>(1)</sup>	W/W	3,10	3,12	3,10	3,11	3,11	3,10	3,12	3,11	3,11	3,11	3,10
SEER <sup>(2)</sup>	kWh/kWh	4,11	4,25	4,12	4,27	4,15	4,14	4,22	4,20	4,30	4,20	4,25
$\eta_{s,c}$ <sup>(2)</sup>	%	161	167	162	168	163	163	166	165	169	165	167
Sound power <sup>(3)</sup>	dB (A)	81	81	81	83	84	81	83	84	84	84	86
Sound pressure <sup>(4)</sup>	dB (A)	49	49	49	51	52	49	51	52	52	52	54
Water tank volume	l	500	500	500	500	500	1000	1000	1000	1000	1000	1000
HE/XL/CO		1602	1802	2002	2302	2502	2504	3004	3204	3504	4004	4504
Cooling capacity (EN14511) <sup>(1)</sup> kW		130,1	150,1	166,8	189,1	211,0	208,5	236,0	264,0	297,8	337,4	383,5
Total input power (EN14511) <sup>(1)</sup> kW		42,0	48,1	53,6	60,8	67,8	67,3	75,6	84,9	95,4	108,5	122,9
EER (EN14511) <sup>(1)</sup>	W/W	3,10	3,12	3,11	3,11	3,11	3,10	3,12	3,11	3,12	3,11	3,12
SEER <sup>(2)</sup>	kWh/kWh	4,40	4,45	4,35	4,35	4,28	4,30	4,40	4,35	4,38	4,30	4,40
$\eta_{s,c}$ <sup>(2)</sup>	%	173	175	171	171	168	169	173	171	172	169	173
Sound power <sup>(3)</sup>	dB (A)	81	81	81	83	84	81	83	84	84	84	86
Sound pressure <sup>(4)</sup>	dB (A)	49	49	49	51	52	49	51	52	52	52	54
Power supply	V/Ph/Hz	400/3/50	400/3/50	400/3/50	400/3/50	400/3/50	400/3/50	400/3/50	400/3/50	400/3/50	400/3/50	400/3/50
Compressors / Circuits	n° / n°	2 / 1	2 / 1	2 / 1	2 / 1	2 / 1	4 / 2	4 / 2	4 / 2	4 / 2	4 / 2	4 / 2
Fans	n°	3	3	3	3	3	4	6	6	6	6	8
Refrigerant		R410A	R410A	R410A	R410A	R410A	R410A	R410A	R410A	R410A	R410A	R410A
Refrigerant charge	kg	30,0	30,0	30,0	30,0	40,0	40,0	50,0	60,0	50,0	60,0	90,0
Global warming potential (GWP)		2088	2088	2088	2088	2088	2088	2088	2088	2088	2088	2088
Equivalent CO <sub>2</sub> charge	t	62,64	62,64	62,64	62,64	83,52	83,52	104,40	152,28	104,40	152,28	187,92
Water tank volume	l	500	500	500	500	500	1000	1000	1000	1000	1000	1000

Performances are referred to the following conditions:

(1) Cooling: ambient air temperature 35°C, evaporator water temperature in/out 12/7 °C.

(2) In accordance with (EU) 2016/2281 and relative norms part of this

(3) Sound power level in accordance with ISO 3744.

(4) Sound pressure level at 10 mt from the unit in free field conditions in accordance with ISO 3744.

## Units only available for the non-EU market

SA/LS/CO	242	292	402	432	492	592	702	802	902	1002	1202	1402	
Cooling capacity (EN14511) <sup>(1)</sup> kW	18,7	25,3	30,0	40,5	46,1	51,8	57,1	64,4	73,4	87,0	95,0	108,2	
Total input power (EN14511) <sup>(1)</sup> kW	6,6	9,2	10,8	14,0	16,6	19,6	20,9	22,7	27,6	31,1	36,0	40,1	
EER (EN14511) <sup>(1)</sup>	W/W	2,83	2,76	2,77	2,90	2,77	2,64	2,73	2,84	2,66	2,80	2,64	2,70
SEER <sup>(2)</sup>	kWh/kWh	3,85	3,90	3,83	3,81	3,82	3,84	3,88	3,85	3,80	3,83	3,81	3,85
$\eta_{s,c}$ <sup>(2)</sup>	%	151	153	150	149	150	151	152	151	149	150	149	151
Sound power <sup>(3)</sup>	dB (A)	75	75	75	75	77	77	78	79	82	83	85	
Sound pressure <sup>(4)</sup>	dB (A)	43	43	43	43	45	45	46	47	50	51	53	
Water tank volume	l	100	100	100	100	100	100	300	300	300	500	500	500
SE/LS/CO	242	292	402	432	492	592	702	802	902	1002	1202	1402	
Cooling capacity (EN14511) <sup>(1)</sup> kW	18,5	25,3	29,8	40,3	46,1	52,1	57,6	65,0	74,0	87,0	95,0	109,1	
Total input power (EN14511) <sup>(1)</sup> kW	6,6	9,2	10,8	13,8	16,4	19,5	20,7	22,5	27,4	30,6	35,6	39,7	
EER (EN14511) <sup>(1)</sup>	W/W	2,82	2,76	2,77	2,93	2,80	2,68	2,78	2,89	2,70	2,84	2,67	2,75
SEER <sup>(2)</sup>	kWh/kWh	4,02	4,05	4,00	3,95	3,96	3,97	3,97	3,96	3,90	3,95	3,99	4,00
$\eta_{s,c}$ <sup>(2)</sup>	%	158	159	157	155	155	1556	156	155	153	155	157	157
Sound power <sup>(3)</sup>	dB (A)	73	74	74	75	77	77	78	79	82	83	84	
Sound pressure <sup>(4)</sup>	dB (A)	41	42	42	43	45	45	46	47	50	51	52	
Power supply	V/Ph/Hz	400/3+N/50	400/3+N/50	400/3+N/50	400/3/50	400/3/50	400/3/50	400/3/50	400/3/50	400/3/50	400/3/50	400/3/50	400/3/50
Compressors / Circuits	n° / n°	2 / 1	2 / 1	2 / 1	2 / 1	2 / 1	2 / 1	2 / 1	2 / 1	2 / 1	2 / 1	2 / 1	2 / 1
Fans	n°	1	1	2	2	2	2	2	2	2	3	3	3
Refrigerant		R410A	R410A	R410A	R410A	R410A	R410A	R410A	R410A	R410A	R410A	R410A	R410A
Refrigerant charge	kg	6,5	6,5	6,5	8,5	8,5	8,5	8,5	14,5	17,0	17,0	17,0	17,0
Global warming potential (GWP)		2088	2088	2088	2088	2088	2088	2088	2088	2088	2088	2088	2088
Equivalent CO <sub>2</sub> charge	t	13,57	13,57	13,57	17,74	17,74	17,74	17,74	30,27	35,49	35,49	35,49	35,49
Water tank volume	l	100	100	100	100	100	100	300	300	300	500	500	500

## Units only available for the non-EU market

SA/LS/CO	1602	1802	2002	2302	2502	2504	3004	3204	3504	4004	4504	5004	
Cooling capacity (EN14511) <sup>(1)</sup> kW	121,7	139,1	153,0	182,3	205,3	200,4	220,2	244,6	296,6	326,6	366,7	414,0	
Total input power (EN14511) <sup>(1)</sup> kW	44,6	50,6	58,8	64,9	73,6	72,3	83,4	92,3	101,2	115,4	130,5	148,4	
EER (EN14511) <sup>(1)</sup>	W/W	2,73	2,75	2,60	2,81	2,79	2,77	2,64	2,65	2,93	2,83	2,81	2,79
SEER <sup>(2)</sup>	kWh/kWh	3,83	3,91	3,90	3,90	3,81	3,80	3,80	3,80	3,81	3,80	3,82	4,10
$\eta_{s,c}$ <sup>(2)</sup>	%	150	153	153	153	149	149	149	149	149	149	150	161
Sound power <sup>(3)</sup>	dB (A)	86	86	86	89	90	87	89	90	90	91	92	93
Sound pressure <sup>(4)</sup>	dB (A)	54	54	54	57	58	55	57	58	58	59	60	61
Water tank volume	l	500	500	500	500	500	500	500	1000	1000	1000	1000	
SE/LS/CO	1602	1802	2002	2302	2502	2504	3004	3204	3504	4004	4504	5004	
Cooling capacity (EN14511) <sup>(1)</sup> kW	122,5	140,2	154,4	183,3	207,1	201,7	221,8	246,2	297,1	327,8	370,6	417,1	
Total input power (EN14511) <sup>(1)</sup> kW	44,2	50,3	58,0	64,5	72,9	71,5	82,5	91,2	100,0	115,0	129,6	146,9	
EER (EN14511) <sup>(1)</sup>	W/W	2,77	2,79	2,66	2,84	2,84	2,82	2,69	2,70	2,97	2,85	2,86	2,84
SEER <sup>(2)</sup>	kWh/kWh	3,95	4,00	4,01	4,01	4,01	3,96	3,97	3,98	4,04	4,00	4,01	4,25
$\eta_{s,c}$ <sup>(2)</sup>	%	155	157	157	157	157	155	156	156	159	157	157	167
Sound power <sup>(3)</sup>	dB (A)	85	85	85	89	90	87	89	90	90	91	92	93
Sound pressure <sup>(4)</sup>	dB (A)	53	53	53	57	58	55	57	58	58	59	60	61
Power supply	V/Ph/Hz	400/3/50	400/3/50	400/3/50	400/3/50	400/3/50	400/3/50	400/3/50	400/3/50	400/3/50	400/3/50	400/3/50	400/3/50
Compressors / Circuits	n° / n°	2 / 1	2 / 1	2 / 1	2 / 1	2 / 1	4 / 2	4 / 2	4 / 2	4 / 2	4 / 2	4 / 2	4 / 2
Fans	n°	4	4	4	3	4	4	4	4	6	6	6	8
Refrigerant		R410A	R410A	R410A	R410A	R410A	R410A	R410A	R410A	R410A	R410A	R410A	R410A
Refrigerant charge	kg	18,0	30,0	25,0	33,0	33,0	40,0	40,0	50,0	60,0	70,0	90,0	90,0
Global warming potential (GWP)		2088	2088	2088	2088	2088	2088	2088	2088	2088	2088	2088	2088
Equivalent CO <sub>2</sub> charge	t	37,58	62,64	52,20	69,90	69,90	83,52	83,52	104,40	152,28	146,16	187,92	187,92
Water tank volume	l	500	500	500	500	500	500	500	500	1000	1000	1000	1000

Performances are referred to the following conditions:

(1) Cooling: ambient air temperature 35°C, evaporator water temperature in/out 12/7 °C.

(2) In accordance with (EU) 2016/2281 and relative norms part of this.

(3) Sound power level in accordance with ISO 3744.

(4) Sound pressure level at 10 mt from the unit in free field conditions in accordance with ISO 3744.

## Units only available for the non-EU market

SA/XL/CO	252	302	402	432	492	592	702	802	902	1002	1202	1402
Cooling capacity (EN14511) <sup>(1)</sup> kW	18,8	25,5	29,5	39,7	44,3	50,4	55,8	63,0	71,1	85,2	92,7	105,2
Total input power (EN14511) <sup>(1)</sup> kW	6,7	9,2	11,0	14,1	15,3	18,6	21,3	23,1	28,3	31,4	36,8	41,1
EER (EN14511) <sup>(1)</sup>	W/W	2,80	2,76	2,67	2,82	2,89	2,71	2,62	2,73	2,51	2,71	2,52
SEER <sup>(2)</sup>	kWh/kWh	3,80	3,85	3,87	3,83	3,82	3,90	3,83	3,84	3,80	3,90	3,81
$\eta_{s,c}$ <sup>(2)</sup>	%	149	151	152	150	150	153	150	151	149	153	149
Sound power <sup>(3)</sup>	dB (A)	71	71	71	71	75	75	75	76	77	80	82
Sound pressure <sup>(4)</sup>	dB (A)	39	39	39	39	43	43	43	44	45	48	50
Water tank volume	l	100	100	100	100	100	100	300	300	300	500	500

SA/XL/CO	1602	1802	2002	2302	2502	2504	3004	3204	3504	4004	4504	5004
Cooling capacity (EN14511) <sup>(1)</sup> kW	118,0	135,5	148,2	175,9	198,0	193,1	210,6	232,2	286,8	314,4	355,2	395,0
Total input power (EN14511) <sup>(1)</sup> kW	45,7	51,9	60,0	65,6	73,3	72,3	83,9	94,0	100,6	116,4	131,6	146,3
EER (EN14511) <sup>(1)</sup>	W/W	2,58	2,61	2,47	2,68	2,70	2,67	2,51	2,47	2,85	2,70	2,70
SEER <sup>(2)</sup>	kWh/kWh	3,82	3,93	3,82	3,93	3,83	3,81	3,84	3,80	3,92	3,82	3,95
$\eta_{s,c}$ <sup>(2)</sup>	%	150	154	150	154	150	149	151	149	154	150	155
Sound power <sup>(3)</sup>	dB (A)	85	85	85	87	89	85	87	88	88	88	90
Sound pressure <sup>(4)</sup>	dB (A)	53	53	53	55	57	53	55	56	56	56	58
Water tank volume	l	500	500	500	500	500	500	500	500	1000	1000	1000

Performances are referred to the following conditions:

- (1) Cooling: ambient air temperature 35°C, evaporator water temperature in/out 12/7 °C.  
 (2) In accordance with (EU) 2016/2281 and relative norms part of this.

(3) Sound power level in accordance with ISO 3744.

(4) Sound pressure level at 10 mt from the unit in free field conditions in accordance with ISO 3744.

## COMPONENTS

### FRAME

All units are made from hot-galvanised sheet steel, painted with polyurethane powder enamel and stoved at 180°C to provide maximum protection against corrosion. The frame is self-supporting with removable panels. All screws and rivets used are made from stainless steel. The standard colour of the units is RAL9018.

### REFRIGERANT CIRCUIT

The refrigerant utilised is R410A. The refrigerant circuit is assembled using internationally recognised brand name components with all brazing and welding being performed in accordance with ISO 97/23. The refrigerant circuit includes: sight glass, filter drier, thermal expansion valve with external equalizer, Schrader valves for maintenance and control, pressure safety device (for compliance with PED regulations).

### COMPRESSORS

The compressors used are a high performance scroll type. In all units the compressors are connected in tandem. This results in much higher efficiencies at part loads compared to units with independent refrigerant circuits.

The compressors are all supplied with a crankcase heater and thermal overload protection by a klixon embedded in the motor winding. They are mounted in a separate enclosure in order to be separated from the air stream thus enabling them to be maintained even if the unit is operating. Access to this enclosure is by the front panel of the unit. The crankcase heater is always powered when the compressor is in stand-by.

### SOURCE HEAT EXCHANGER

The source heat exchanger is made from copper pipes and aluminium fins. Dimensioning of the copper pipes and the aluminium fins is optimized in order to obtain excellent performance. The tubes are mechanically expanded into the fins in order to maximise heat transfer. Furthermore, the design guarantees a low air side pressure drop thus enabling the use of low rotation speed (and hence low noise) fans. All heat exchangers are supplied standard with fins hydrophilic coating.

### USER HEAT EXCHANGERS

The user heat exchanger is a braze welded, plate type heat exchanger, manufactured from AISI 316 stainless steel. The use of this type of exchanger results in a massive reduction of the refrigerant charge of the unit compared to a traditional shell-

in-tube type. A further advantage is a reduction in the overall dimensions of the unit.

The exchangers are factory insulated with flexible close cell material and can be fitted with an antifreeze heater (accessory). Each exchanger is fitted with a temperature sensor on the discharge water side for antifreeze protection.

### FANS

The fans are direct drive axial type with aluminium aerofoil blades, are statically and dynamically balanced and are supplied complete with a safety fan guard complying with the requirements of EN 60335.

They are fixed to the unit frame via rubber anti-vibration mountings. The electric motors, in LS versions are 6 poles type rotating at approximately 900 rpm. In the XL versions the fans are 8 poles type (approx 600 rpm). The motors are fitted with integrated thermal overload protection and have a moisture protection rating of IP 54.

### MICROPROCESSORS

All units are supplied as standard complete with control panel. The microprocessor controls the following functions: control of the water temperature, antifreeze protection, compressor timing, compressor automatic starting sequence, alarm reset, volt free contact for remote general alarm, alarms and operation LED's. If required (available as an option), the microprocessor can be configured in order for it to connect to a site BMS system thus enabling remote control and management. The Hidros technical department can discuss and evaluate, in conjunction with the customer, solutions using MODBUS protocols.

### ELECTRIC ENCLOSURE

The enclosure is manufactured in order to comply with the requirements of the electromagnetic compatibility standards CEE EN60204. Access to the enclosure is quick and easy thanks to hinged panels. The following components are supplied as standard on all units: main switch, a sequence relay that disables the power supply in the event that the phase sequence is incorrect (scroll compressors can be damaged if they rotate in the wrong direction), thermal overloads (protection of pumps and fans), compressor fuses, control circuit automatic breakers, compressor contactors, fan contactors and pump contactors. The terminal board has volt free contacts for remote ON-OFF, Summer/ winter change over (heat pumps only) and general alarm.

## CONTROL AND PROTECTION DEVICES

All units are supplied with the following control and protection devices: Return water temperature sensor installed on the return water line from the building, antifreeze protection sensor installed on the outlet water temperature, high pressure switch with manual reset, low pressure switch with automatic reset, high pressure safety valve, compressor thermal overload protection, fans thermal overload protection and flow switch.

## VERSIONS

### CO Version

Cooling only version, chilled water available down to a minimum temperature of 4°C.

### BT Version

Low user water temperature; supplied with a specific cooling circuit allowing the unit to operate with user chilled water between +4°C and -5°C.

### SA Version

Standard efficiency version, for the non-EU market. Unit equipped with AC fans.

### SE Version

Standard efficiency version, according to current standard. Unit equipped with EC fans.

### HA Version

High efficiency version, according to current standard. Unit equipped with AC fans.

### HE Version

High efficiency version, according to current standard. Unit equipped with EC fans.

## LS Version

This version includes the complete acoustic insulation of the unit with compressor jackets and insulating material made with high density media and the interposition of heavy bitumen layer.

## XL Version

Units in XL version are supplied, as standard, with the latest 'Floating Frame' technology that completely isolates the compressors from the main casing, thereby eliminating vibration and noise from this source. The 'Floating Frame' is a special vibration and acoustic damping system that consists of a base plate and acoustic enclosure that houses the compressors. The base plate is separated from the supporting frame of the unit by soft steel springs that have a high damping power. Within the enclosure, the compressors are mounted on rubber shock absorbers on the floating base plate. The enclosure is manufactured from galvanized steel sandwich panels that have a micro-perforated inner skin and a core of 30 mm thick, high density (25 kg/m<sup>3</sup>). The entire arrangement provides a double damping system and acoustic attenuation. The compressor refrigerant pipes are connected to the refrigerant circuit through "anaconda" flexible connections. Flexible connections are also used on the water pipework within the unit. The combination of these systems results in an overall noise reduction in the region of 6–8 dB(A). Unit equipped with low rotation speed fans (approx. 600 rpm).

## OPERATION LIMITS

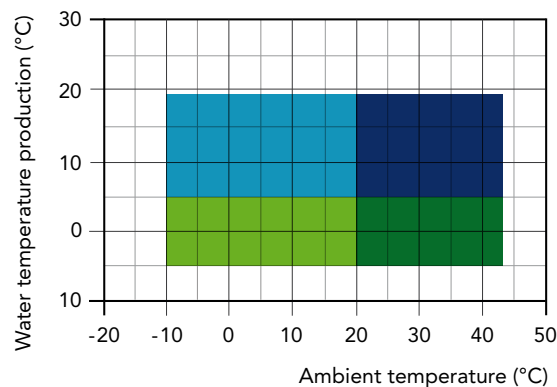

- Cooling mode with cond. press. contr.
- Cooling mode
- Cooling mode with cond. press. contr. and glycol (Only BT versions)
- Cooling mode with glycol (Only BT versions)

## FLOATING FRAME - XL VERSION

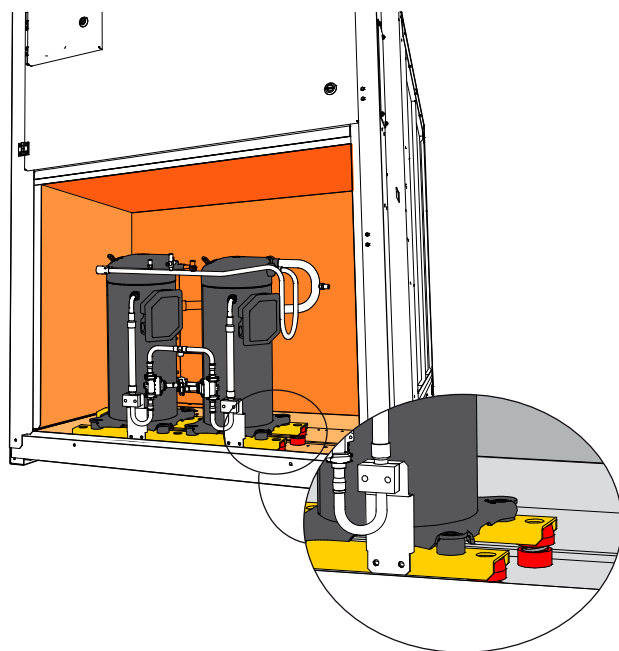

LDA		242	252	292	302	402	412	432	492	592	602	702	802
Flow switch		●	●	●	●	●	●	●	●	●	●	●	●
"Floating frame" Technology - LS Version		-	-	-	-	-	-	-	-	-	-	-	-
"Floating frame" Technology - XL Version		●	●	●	●	●	●	●	●	●	●	●	●
E.C. fans - SE versions	VECE	●	●	●	●	●	●	●	●	●	●	●	●
A.C. fans - HA versions	VECE	-	-	-	-	-	-	-	-	-	-	-	-
E.C. fans - HE versions	VECE	●	●	●	●	●	●	●	●	●	●	●	●
Evap/cond. press. control by transducer and fan speed control	DCCF	○	○	○	○	○	○	○	○	○	○	○	○
Antifreeze kit for 2 pipe units	RAEV2	○	○	○	○	○	○	○	○	○	○	○	○
Electronic soft starter	DSSE	○	○	○	○	○	○	○	○	○	○	○	○
Serial interface card RS485	INSE	○	○	○	○	○	○	○	○	○	○	○	○
Rubber anti-vibration mountings	KAVG	○	○	○	○	○	○	○	○	○	○	○	○
Remote control panel	PCRL	○	○	○	○	○	○	○	○	○	○	○	○
Electronic expansion valve	VTEE	○	○	○	○	○	○	○	○	○	○	○	○
Cascade control system via RS485	SGRS	○	○	○	○	○	○	○	○	○	○	○	○
Hydraulic kit with one pump with tank	A1ZZU	○	○	○	○	○	○	○	○	○	○	○	○
Hydraulic kit with two pumps with tank	A2ZZU	○	○	○	○	○	○	○	○	○	○	○	○
Hydraulic kit with one pump without tank	A1NTU	○	○	○	○	○	○	○	○	○	○	○	○
Hydraulic kit with two pumps without tank	A2NTU	○	○	○	○	○	○	○	○	○	○	○	○

● Standard ○ Optional - Not available

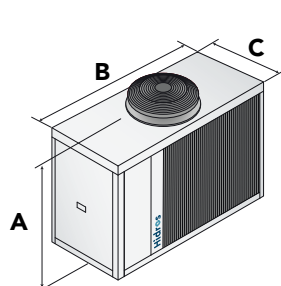

**SA/SE LS** 242 - 292  
**HA/HE LS** 242 - 292

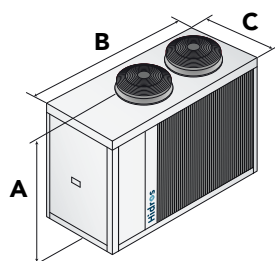

**SA/SE XL** 252 - 302 - 402  
**HA/HE XL** 252 - 302

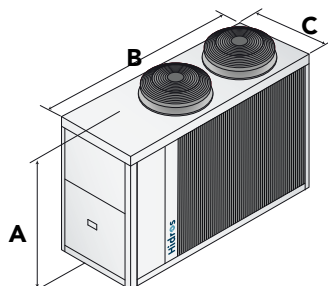

**SA/SE-LS/XL** 432 - 492 - 592  
**HA/HE-LS/XL** 412 - 432 - 492

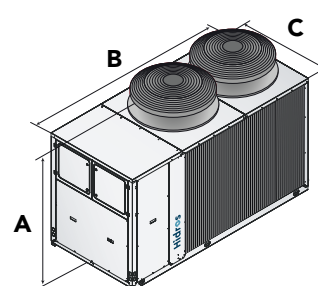

**SA/SE-LS/XL** 702 - 802 - 902  
**HA/HE-LS/XL** 602 - 702 - 802 - 902  
1002 - 1202

		242/252	292/302	402	412	432	492	592	602	702	802
A	<b>SA-SE/LS</b>	1500	1500	1500	--	1690	1690	1690	--	1820	1820
B	<b>SA-SE/LS</b>	1915	1915	1915	--	2400	2400	2400	--	2905	2905
C	<b>SA-SE/LS</b>	875	875	875	--	1150	1150	1150	--	1150	1150
kg	<b>SA-SE/LS</b>	550	550	560	--	670	700	760	--	880	890
A	<b>SA-SE/XL</b>	1500	1500	1500	--	1690	1690	1690	--	1880	1820
B	<b>SA-SE/XL</b>	1915	1915	1915	--	2400	2400	2400	--	2905	2905
C	<b>SA-SE/XL</b>	875	875	875	--	1150	1150	1150	--	1150	1150
kg	<b>SA-SE/XL</b>	550	550	560	--	670	700	760	--	880	890
A	<b>HA-HE/LS</b>	1500	1500	--	1690	1690	1690	--	1820	1820	1820
B	<b>HA-HE/LS</b>	1915	1915	--	2400	2400	2400	--	2905	2905	2905
C	<b>HA-HE/LS</b>	875	875	--	1150	1150	1150	--	1150	1150	1150
kg	<b>HA-HE/LS</b>	560	560	--	670	690	720	--	1040	1060	1070
A	<b>HA-HE/XL</b>	1500	1500	--	1690	1690	1690	--	1820	1820	1820
B	<b>HA-HE/XL</b>	1915	1915	--	2400	2400	2400	--	2905	2905	2905
C	<b>HA-HE/XL</b>	875	875	--	1150	1150	1150	--	1150	1150	1150
kg	<b>HA-HE/XL</b>	570	570	--	680	710	740	--	1060	1080	1090

LDA		902	1002	1202	1402	1602	1802	2002	2302
Flow switch		●	●	●	●	●	●	●	●
"Floating frame" Technology - LS Version		-	-	-	-	-	-	-	-
"Floating frame" Technology - XL Version		●	●	●	●	●	●	●	●
E.C. fans - SA versions	VECE	-	-	-	-	-	-	-	-
E.C. fans - SE versions	VECE	●	●	●	●	●	●	●	●
E.C. fans - HA versions	VECE	-	-	-	-	-	-	-	-
E.C. fans - HE versions	VECE	●	●	●	●	●	●	●	●
Evap/cond. press. control by transducer and fan speed control	DCCF	○	○	○	○	○	○	○	○
Antifreeze kit for 2 pipe units	RAEV2	○	○	○	○	○	○	○	○
Electronic soft starter	DSSE	○	○	○	○	○	○	○	○
Serial interface card RS485	INSE	○	○	○	○	○	○	○	○
Rubber anti-vibration mountings	KAVG	○	○	○	○	○	○	○	○
Remote control panel	PCRL	○	○	○	○	○	○	○	○
Electronic expansion valve	VTEE	○	○	○	○	○	○	○	○
Cascade control system via RS485	SGRS	○	○	○	○	○	○	○	○
Hydraulic kit with one pump with tank	A1ZZU	○	○	○	○	○	○	○	○
Hydraulic kit with two pumps with tank	A2ZZU	○	○	○	○	○	○	○	○
Hydraulic kit with one pump without tank	A1NTU	○	○	○	○	○	○	○	○
Hydraulic kit with two pumps without tank	A2NTU	○	○	○	○	○	○	○	○

● Standard ○ Optional - Not available

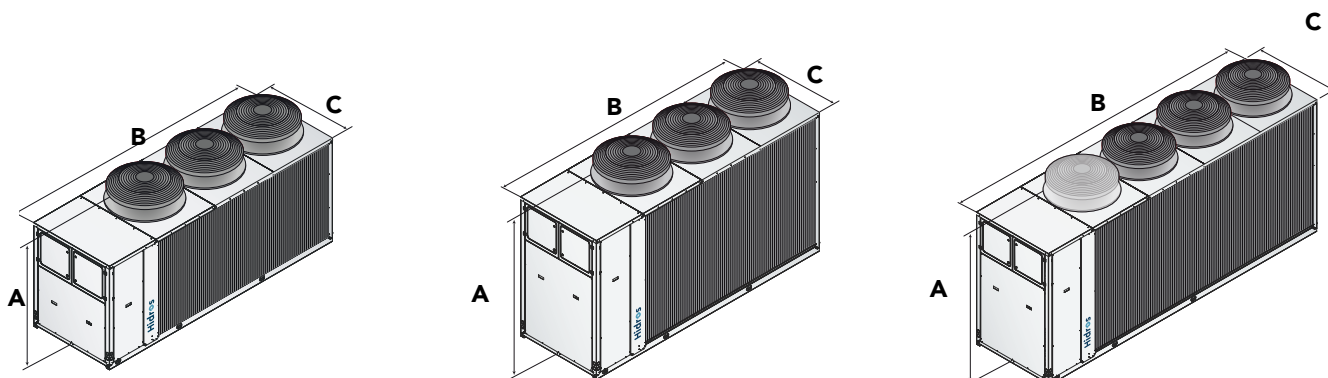

**SA/SE-LS/XL** 1002 - 1202 - 1402 - 1602  
**HA/HE-LS/XL** 1402 - 1602 - 1802 - 2002

**SA/SE-LS/XL** 1802 - 2002  
**HA/HE-LS/XL** 2302 - 2502

**SA/SE-LS/XL** 2302 - 2502

		902	1002	1202	1402	1602	1802	2002	2302
A	<b>SA-SE/LS</b>	1820	1820	1820	1820	1820	2270	2270	2310
B	<b>SA-SE/LS</b>	2905	3905	3905	3905	3905	3905	3905	4505
C	<b>SA-SE/LS</b>	1150	1150	1150	1150	1150	1150	1150	1150
kg	<b>SA-SE/LS</b>	890	1170	1240	1290	1330	1660	1680	1950
A	<b>SA-SE/XL</b>	1880	1880	1880	1880	1880	2270	2270	2310
B	<b>SA-SE/XL</b>	2905	3905	3905	3905	3905	3905	3905	4505
C	<b>SA-SE/XL</b>	1150	1150	1150	1150	1150	1150	1150	1150
kg	<b>SA-SE/XL</b>	890	1170	1240	1290	1330	1660	1680	1950
A	<b>HA-HE/LS</b>	1880	1880	1880	1880	1880	1880	1880	2270
B	<b>HA-HE/LS</b>	2905	2905	2905	3905	3905	3905	3905	3905
C	<b>HA-HE/LS</b>	1150	1150	1150	1150	1150	1150	1150	1150
kg	<b>HA-HE/LS</b>	1100	1140	1210	1530	1550	1570	1590	1750
A	<b>HA-HE/XL</b>	1880	1880	1880	1880	1880	1880	1880	2270
B	<b>HA-HE/XL</b>	2905	2905	2905	3905	3905	3905	3905	3905
C	<b>HA-HE/XL</b>	1150	1150	1150	1150	1150	1150	1150	1150
kg	<b>HA-HE/XL</b>	1120	1160	1230	1560	1580	1600	1620	1780



LDA		2502	2504	3004	3204	3504	4004	4504	5004
Flow switch		●	●	●	●	●	●	●	●
"Floating frame" Technology - LS Version		-	-	-	-	-	-	-	-
"Floating frame" Technology - XL Version		●	●	●	●	●	●	●	●
E.C. fans - SA versions	VECE	-	-	-	-	-	-	-	-
E.C. fans - SE versions	VECE	●	●	●	●	●	●	●	●
E.C. fans - HA versions	VECE	-	-	-	-	-	-	-	-
E.C. fans - HE versions	VECE	●	●	●	●	●	●	●	●
Evap/cond. press. control by transducer and fan speed control	DCCF	○	○	○	○	○	○	○	○
Antifreeze kit for 2 pipe units	RAEV2	○	○	○	○	○	○	○	○
Electronic soft starter	DSSE	○	○	○	○	○	○	○	○
Serial interface card RS485	INSE	○	○	○	○	○	○	○	○
Rubber anti-vibration mountings	KAVG	○	○	○	○	○	○	○	○
Remote control panel	PCRL	○	○	○	○	○	○	○	○
Electronic expansion valve	VTEE	○	○	○	○	○	○	○	○
Cascade control system via RS485	SGRS	○	○	○	○	○	○	○	○
Hydraulic kit with one pump with tank	A1ZZU	○	○	○	○	○	○	○	○
Hydraulic kit with two pumps with tank	A2ZZU	○	○	○	○	○	○	○	○
Hydraulic kit with one pump without tank	A1NTU	○	○	○	○	○	○	○	○
Hydraulic kit with two pumps without tank	A2NTU	○	○	○	○	○	○	○	○

● Standard ○ Optional - Not available

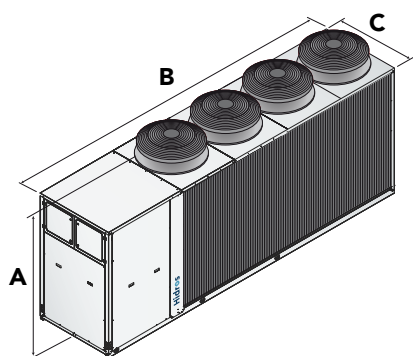

**SA/SE-LS/XL** 2504 - 3004 - 3204

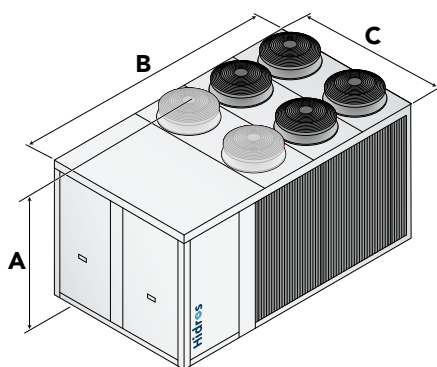

**SA/SE-LS/XL** 3504 - 4004  
**HA/HE-LS/XL** 2504 - 3004 - 3204 - 3504

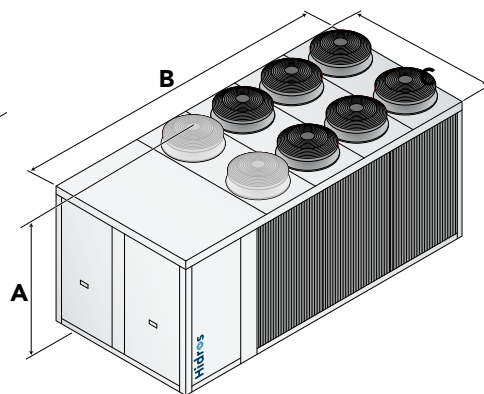

**SA/SE-LS/XL** 4504 - 5004  
**HA/HE-LS/XL** 4004 - 4504 - 5004

		2502	2504	3004	3204	3504	4004	4504	5004
A	<b>SA-SE/LS</b>	2310	2310	2310	2310	2350	2350	2380	2380
B	<b>SA-SE/LS</b>	4505	5300	5300	5300	4205	4205	4810	4810
C	<b>SA-SE/LS</b>	1150	1150	1150	1150	2210	2210	2210	2210
kg	<b>SA-SE/LS</b>	2000	2460	2500	2580	3170	3220	3550	3650
A	<b>SA-SE/XL</b>	2310	2310	2310	2310	2350	2350	2380	2380
B	<b>SA-SE/XL</b>	4505	5300	5300	5300	4205	4205	4810	4810
C	<b>SA-SE/XL</b>	1150	1150	1150	1150	2210	2210	2210	2210
kg	<b>SA-SE/XL</b>	2000	2460	2500	2580	3170	3220	3550	3650
A	<b>HA-HE/LS</b>	2270	2350	2350	2350	2350	2380	2380	2380
B	<b>HA-HE/LS</b>	3905	4205	4205	4205	4205	4805	4810	4810
C	<b>HA-HE/LS</b>	1150	2210	2210	2210	2210	2210	2210	2210
kg	<b>HA-HE/LS</b>	1780	3120	3170	3220	3270	3610	3670	3720
A	<b>HA-HE/XL</b>	2270	2350	2350	2350	2350	2380	2380	2380
B	<b>HA-HE/XL</b>	3905	4205	4205	4205	4205	4805	4810	4810
C	<b>HA-HE/XL</b>	1150	2210	2210	2210	2210	2210	2210	2210
kg	<b>HA-HE/XL</b>	1810	3170	3220	3270	3320	3660	3720	3770

CHID.23GB.A

**Hidros**  
INNOVATION AS ENERGY



AN ENEX TECHNOLOGIES COMPANY

Sede legale: via Alessandro Volta 49  
- 47014 Meldola (FC) Italy  
Sede operativa: via Enrico Mattei 20  
- 35028 Piove di Sacco (PD) Italy

[www.hidros.it](http://www.hidros.it)  
[info@hidros.it](mailto:info@hidros.it)