

LHi/P4

4 pipe systems high efficiency air to water heat pumps with INVERTER compressor

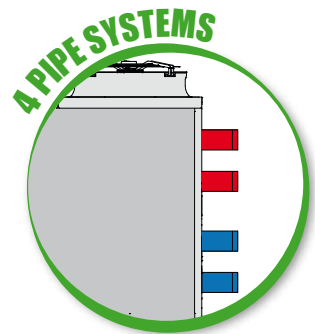
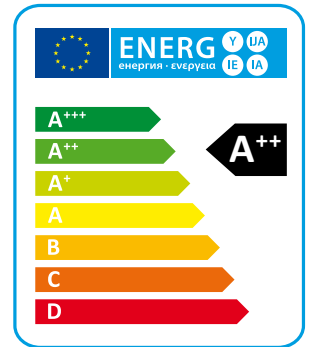
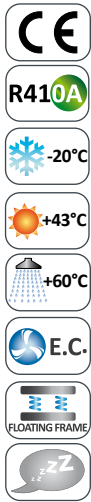

The LHi P4U/P4S series high-efficiency air-to-water heat pumps are units designed for four-pipe air conditioning and heating systems, which allow the simultaneous or separate production of cold water for cooling and hot water for heating. The units are supplied with an additional exchanger, used as a condenser for hot water, whose production is independent of the unit's operating mode. The exchanger is automatically activated by microprocessor control when the hot water temperature on the return flow is lower than the set applied. These units are able to produce hot water and cold water simultaneously and/or separately with very high energy efficiency.

They are all supplied complete with a specific advanced microprocessor control equipped with software for the management of the various priorities.

The XL versions also have an extremely low noise level thanks to the use of a special floating vibration dampening system that allows a noise reduction of about 5-7 dB(A) (optional).

Versions

- RV** Reversible heating/cooling.
- SE** Standard efficiency, EC fans.
- LS** Low noise.
- XL** Super low noise.
- P4U** 4 pipe systems heating/cooling.
- P4S** 2+2 pipe systems with D.H.W. production.

SE/LS/RV - P4S		532	632	742	862	912	1052	1222	1534	1654	1854	1964	2254	2554
Heating capacity (EN14511) ⁽¹⁾	kW	53,3	61,8	74,2	85,1	90,9	102,5	118,3	129,0	145,3	165,2	188,7	223,4	269,6
Total input power (EN14511) ⁽¹⁾	kW	13,2	14,7	18,7	20,0	22,1	24,9	28,5	31,2	34,0	39,1	44,8	55,1	65,8
COP (EN14511) ⁽¹⁾	W/W	4,04	4,19	3,97	4,25	4,11	4,12	4,15	4,14	4,27	4,23	4,21	4,06	4,10
Energy Class ⁽²⁾		A++	A++	A++	A++	A++	A++	A++	A++	A++	A++	A++	A++	A++
SCOP ⁽²⁾	kWh/kWh	3,88	3,93	3,90	3,98	3,92	3,93	3,88	3,95	3,93	4,00	3,90	3,88	3,88
ηs,h ⁽²⁾	%	152	154	153	156	154	154	152	155	154	157	153	152	152
Cooling capacity (EN14511) ⁽³⁾	kW	49,32	57,71	68,9	78,87	83,19	95,32	109,3	112,8	129,4	146,3	162,5	197,4	230,6
Total input power (EN14511) ⁽³⁾	kW	16,42	18,47	24,48	25,78	28,18	31,81	36,3	40,3	42,6	50,2	57,0	69,5	84,6
EER (EN14511) ⁽³⁾	W/W	3,00	3,12	2,81	3,06	2,95	3,00	3,01	2,80	3,04	2,91	2,85	2,84	2,72
TER (EN 14511) ⁽⁴⁾		10,00	10,27	9,72	10,12	9,84	9,98	10,08	10,32	10,45	10,43	9,99	9,94	9,78
Sound power level ⁽⁵⁾	dB (A)	81	81	83	83	83	84	85	86	87	87	87	89	89
Sound pressure level ⁽⁶⁾	dB (A)	49	49	51	51	51	52	53	54	55	55	55	57	57
Power supply	V/Ph/Hz	400/3/50	400/3/50	400/3/50	400/3/50	400/3/50	400/3/50	400/3/50	400/3/50	400/3/50	400/3/50	400/3/50	400/3/50	400/3/50
Compressors / Circuits	n° / n°	2 / 1	2 / 1	2 / 1	2 / 1	2 / 1	2 / 1	2 / 1	4 / 2	4 / 2	4 / 2	4 / 2	4 / 2	4 / 2
Fans	n°	2	2	2	3	3	3	4	2	3	3	3	4	4
Refrigerant		R410A	R410A	R410A	R410A	R410A	R410A	R410A	R410A	R410A	R410A	R410A	R410A	R410A
Refrigerant charge	kg	10,4	14,7	14,7	17,5	17,5	22,3	22,7	32,6	39,8	39,8	45,5	50,9	59,0
Global warming potential (GWP)		2088	2088	2088	2088	2088	2088	2088	2088	2088	2088	2088	2088	2088
Equivalent CO ₂ charge	t	21,8	30,7	30,7	36,5	36,5	46,5	47,4	68,0	83,2	83,2	95,0	106,2	123,1
Water tank volume	l	140	300	300	500	500	500	500	300	500	500	500	500	500

SE/LS/RV - P4U		532	632	742	862	912	1052	1222	1534	1654	1854	1964	2254	2554
Heating capacity (EN14511) ⁽¹⁾	kW	53,2	61,8	74,5	86,4	90,9	102,4	118,3	129,5	146,2	166,9	189,9	224,4	270,6
Total input power (EN14511) ⁽¹⁾	kW	12,8	14,3	18,2	19,8	21,5	24,3	27,9	30,3	33,0	38,1	43,4	53,4	63,4
COP (EN14511) ⁽¹⁾	W/W	4,17	4,31	4,09	4,36	4,22	4,22	4,24	4,28	4,43	4,38	4,38	4,20	4,27
Energy Class ⁽²⁾		A++	A++	A++	A++	A++	A++	A++	A++	A++	A++	A++	A++	A++
SCOP ⁽²⁾	kWh/kWh	3,93	3,98	4,00	4,05	3,98	3,95	3,85	4,05	4,00	4,05	3,98	3,93	3,90
ηs,h ⁽²⁾	%	154	156	157	159	156	155	151	159	157	159	156	154	153
Cooling capacity (EN14511) ⁽³⁾	kW	56,6	66,0	81,1	91,0	96,5	110,9	126,9	133,0	147,2	171,7	188,5	228,7	271,8
Total input power (EN14511) ⁽³⁾	kW	12,6	14,2	18,6	19,9	21,8	24,7	27,9	28,5	31,2	36,4	41,9	51,1	61,9
EER (EN14511) ⁽³⁾	W/W	4,51	4,64	4,37	4,57	4,43	4,50	4,55	4,66	4,73	4,72	4,50	4,47	4,39
TER (EN 14511) ⁽⁴⁾		10,00	10,27	9,72	10,12	9,84	9,98	10,08	10,32	10,45	10,43	9,99	9,94	9,78
Sound power level ⁽⁵⁾	dB (A)	81	81	83	83	83	84	85	86	87	87	87	89	89
Sound pressure level ⁽⁶⁾	dB (A)	49	49	51	51	51	52	53	54	55	55	55	57	57
Power supply	V/Ph/Hz	400/3/50	400/3/50	400/3/50	400/3/50	400/3/50	400/3/50	400/3/50	400/3/50	400/3/50	400/3/50	400/3/50	400/3/50	400/3/50
Compressors / Circuits	n° / n°	2 / 1	2 / 1	2 / 1	2 / 1	2 / 1	2 / 1	2 / 1	4 / 2	4 / 2	4 / 2	4 / 2	4 / 2	4 / 2
Fans	n°	2	2	2	3	3	3	4	2	3	3	3	4	4
Refrigerant		R410A	R410A	R410A	R410A	R410A	R410A	R410A	R410A	R410A	R410A	R410A	R410A	R410A
Refrigerant charge	kg	10,4	14,7	14,7	17,5	17,5	22,3	22,7	32,6	39,8	39,8	45,5	50,9	59,0
Global warming potential (GWP)		2088	2088	2088	2088	2088	2088	2088	2088	2088	2088	2088	2088	2088
Equivalent CO ₂ charge	t	21,8	30,7	30,7	36,5	36,5	46,5	47,4	68,0	83,2	83,2	95,0	106,2	123,1
Water tank volume	l	140	300	300	500	500	500	500	300	500	500	500	500	500

Performances are referred to the following conditions:

(1) Heating: Ambient temperature 7°C DB, 6°C WB, water temperature 30/35°C.

(2) Average conditions, low temperature, variable - Reg EU 811/2013.

(3) Cooling: ambient air temperature 35°C, evaporator water temperature in/out 12/7 °C.

(4) TER: Total Energy Ratio-cold circuit 12/7°C, hot circuit 30/35°C

(5) Sound power level in accordance with ISO 3744.

(6) Sound pressure level at 10 mt from the unit in free field conditions in accordance with ISO 3744.

SE/XL/RV - P4S		532	632	742	862	912	1052	1222	1534	1654	1854	1964	2254	2554
Heating capacity (EN14511) ⁽¹⁾	kW	51,8	59,4	77,1	82,9	87,8	101,9	114,4	126,9	142,2	163,6	184,6	224,7	267,2
Total input power (EN14511) ⁽¹⁾	kW	12,8	14,3	18,6	19,8	21,5	24,2	27,7	30,1	32,3	37,7	42,9	53,3	63,8
COP (EN14511) ⁽¹⁾	W/W	4,04	4,15	4,15	4,20	4,08	4,21	4,13	4,22	4,41	4,35	4,31	4,22	4,19
Energy Class ⁽²⁾		A++	A++	A++	A++	A++	A++	A++	A++	A++	A++	A++	A++	A++
SCOP ⁽²⁾	kWh/kWh	3,95	4,10	4,08	4,13	4,10	4,03	4,00	4,18	4,28	4,25	4,18	4,15	4,13
η _{s,h} ⁽²⁾	%	155	161	160	162	161	158	157	164	168	167	164	163	162
Cooling capacity (EN14511) ⁽³⁾	kW	48,0	55,9	70,4	76,4	80,4	91,9	105,7	109,4	124,9	140,1	154,6	198,5	231,8
Total input power (EN14511) ⁽³⁾	kW	16,3	18,4	22,7	25,6	28,1	32,1	36,2	38,9	40,8	49,4	56,0	62,9	77,9
EER (EN14511) ⁽³⁾	W/W	2,86	2,96	3,00	2,90	2,79	2,80	2,84	2,68	2,93	2,73	2,67	2,97	2,83
TER (EN 14511) ⁽⁴⁾		10,00	10,27	9,72	10,12	9,84	9,98	10,08	10,32	10,45	10,43	9,99	9,94	9,78
Sound power level ⁽⁵⁾	dB (A)	76	77	78	78	79	79	80	80	80	80	82	83	84
Sound pressure level ⁽⁶⁾	dB (A)	44	45	46	46	47	47	48	48	48	48	50	51	52
Power supply	V/Ph/Hz	400/3/50	400/3/50	400/3/50	400/3/50	400/3/50	400/3/50	400/3/50	400/3/50	400/3/50	400/3/50	400/3/50	400/3/50	400/3/50
Compressors / Circuits	n° / n°	2 / 1	2 / 1	2 / 1	2 / 1	2 / 1	2 / 1	2 / 1	4 / 2	4 / 2	4 / 2	4 / 2	4 / 2	4 / 2
Fans	n°	2	2	2	3	3	3	4	2	3	3	3	4	4
Refrigerant		R410A	R410A	R410A	R410A	R410A	R410A	R410A	R410A	R410A	R410A	R410A	R410A	R410A
Refrigerant charge	kg	10,4	14,7	16,3	17,5	17,5	22,3	22,7	32,6	39,8	39,8	32,5	50,9	59,0
Global warming potential (GWP)		2088	2088	2088	2088	2088	2088	2088	2088	2088	2088	2088	2088	2088
Equivalent CO ₂ charge	t	21,8	30,7	34,1	36,5	36,5	46,5	47,4	68,0	83,2	83,2	67,8	106,2	123,1
Water tank volume	l	140	300	300	500	500	500	500	300	500	500	500	500	500

SE/XL/RV - P4U		532	632	742	862	912	1052	1222	1534	1654	1854	1964	2254	2554
Heating capacity (EN14511) ⁽¹⁾	kW	51,2	59,3	77,1	82,8	87,5	97,8	114,0	127,3	143,9	162,5	184,9	217,3	264,7
Total input power (EN14511) ⁽¹⁾	kW	12,4	13,9	18,0	19,3	20,9	23,6	27,1	29,2	31,6	36,4	41,5	50,6	61,8
COP (EN14511) ⁽¹⁾	W/W	4,14	4,25	4,29	4,30	4,18	4,14	4,21	4,36	4,56	4,46	4,46	4,29	4,29
Energy Class ⁽²⁾		A++	A++	A++	A++	A++	A++	A++	A++	A++	A++	A++	A++	A++
SCOP ⁽²⁾	kWh/kWh	3,98	4,15	4,15	4,18	4,13	4,08	4,03	4,28	4,38	4,38	4,33	4,20	4,15
η _{s,h} ⁽²⁾	%	156	163	163	164	162	160	158	168	172	172	170	165	163
Cooling capacity (EN14511) ⁽³⁾	kW	48,0	55,9	70,4	76,4	80,4	91,9	105,7	109,4	124,9	140,1	154,6	198,5	231,8
Total input power (EN14511) ⁽³⁾	kW	16,3	18,4	22,7	25,6	28,1	32,1	36,2	38,9	40,8	49,4	56,0	62,9	77,9
EER (EN14511) ⁽³⁾	W/W	2,86	2,96	3,00	2,90	2,79	2,80	2,84	2,68	2,93	2,73	2,67	2,97	2,83
TER (EN 14511) ⁽⁴⁾		10,00	10,27	9,72	10,12	9,84	9,98	10,08	10,32	10,45	10,43	9,99	9,94	9,78
Sound power level ⁽⁵⁾	dB (A)	76	77	78	78	79	79	80	80	80	80	82	83	84
Sound pressure level ⁽⁶⁾	dB (A)	44	45	46	46	47	47	48	48	48	48	50	51	52
Power supply	V/Ph/Hz	400/3/50	400/3/50	400/3/50	400/3/50	400/3/50	400/3/50	400/3/50	400/3/50	400/3/50	400/3/50	400/3/50	400/3/50	400/3/50
Compressors / Circuits	n° / n°	2 / 1	2 / 1	2 / 1	2 / 1	2 / 1	2 / 1	2 / 1	4 / 2	4 / 2	4 / 2	4 / 2	4 / 2	4 / 2
Fans	n°	2	2	2	3	3	3	4	2	3	3	3	4	4
Refrigerant		R410A	R410A	R410A	R410A	R410A	R410A	R410A	R410A	R410A	R410A	R410A	R410A	R410A
Refrigerant charge	kg	10,4	14,7	16,3	17,5	17,5	22,3	22,7	32,6	39,8	39,8	32,5	50,9	59,0
Global warming potential (GWP)		2088	2088	2088	2088	2088	2088	2088	2088	2088	2088	2088	2088	2088
Equivalent CO ₂ charge	t	21,8	30,7	34,1	36,5	36,5	46,5	47,4	68,0	83,2	83,2	67,8	106,2	123,1
Water tank volume	l	140	300	300	500	500	500	500	300	500	500	500	500	500

Performances are referred to the following conditions:

(1) Heating: Ambient temperature 7°C DB, 6°C WB, water temperature 30/35°C.

(2) Average conditions, low temperature, variable - Reg EU 811/2013.

(3) Cooling: ambient air temperature 35°C, evaporator water temperature in/out 12/7°C.

(4)TER: Total Energy Ratio-cold circuit 12/7°C, hot circuit 30/35°C

(5) Sound power level in accordance with ISO 3744.

(6) Sound pressure level at 10 mt from the unit in free field conditions in accordance with ISO 3744.

Frame

All units are made from hot-galvanised sheet steel, painted with polyurethane powder enamel and stoved at 180°C to provide maximum protection against corrosion. The frame is self-supporting with removable panels. All screws and rivets used are made from stainless steel. The standard colour of the units is RAL9018.

Refrigerant circuit

The refrigerant utilised is R410A. The refrigerant circuit is assembled using internationally recognised brand name components with all brazing and welding being performed in accordance with ISO 97/23. The refrigerant circuit includes: sight glass, filter drier, two thermal expansion valves (one for cooling mode, one for heating mode) with external equalizer, 4 way reversing valve, check valves, liquid receiver, Schrader valves for maintenance and control, pressure safety device (for compliance with PED regulations).

Compressors

The compressors used are three-phase scroll type BPM (brushless permanent magnet) high efficiency, controlled by an Inverter, supplied with a specific design that increases the efficiency of the refrigerant cycle in very low ambient temperature conditions. All sizes use compressors in tandem configuration, and are all optimized for heat pump applications for high seasonal efficiency (SCOP).

The compressors are all supplied with electrical resistance and thermal overload protection. They are all mounted in a dedicated compartment to keep them separated from the airflow. The electric heater is always powered when the compressor is in stand by mode. Maintenance is possible through the front panel of the unit which allows to reach the compressors even when the machine is running.

Source heat exchanger

The source heat exchanger is made from copper pipes and aluminium fins. Dimensioning of the copper pipes and the aluminium wings is optimized in order to obtain excellent performance.

The tubes are mechanically expanded into the fins in order to maximise heat transfer. Furthermore, the design guarantees a low air side pressure drop thus enabling the use of low rotation speed (and hence low noise) fans. All heat exchangers are supplied standard with fins hydrophilic coating.

User heat exchangers (P4U/P4S versions)

The user heat exchanger is a braze welded, plate type heat exchanger, manufactured from AISI 316 stainless steel. The use of this type of exchanger results in a massive reduction of the refrigerant charge of the unit compared to a traditional shell-in-tube type. A further advantage is a reduction in the overall dimensions of the unit.

The exchangers are factory insulated with flexible close cell material and can be fitted with an antifreeze heater (accessory). Each exchanger is fitted with a temperature sensor on the discharge water side for antifreeze protection.

High efficiency E.C. axial fans (VECE)

High efficiency E.C. axial fans, supplied with Brushless DC electric motors electronically commutated (E.C. motors) able to grant the highest energy efficiency class (EFF1), according to the latest EU specifications, with the result of substantial energy consumption

reduction for ventilation and noise reduction thanks to the new ultra efficient blade profiling. The fans are statically and dynamically balanced and supplied complete with a safety fan guard complying with the requirements of EN 60335. The fans are installed using a special steel profiled beam who minimize all vibrations and noise emitted. The average nominal rotation speed is 700 rpm. All units are fitted with a pressure transducer for the control of the evaporation/condensation pressure. All electric motors are The motors are fitted with integrated thermal overload protection rating IP54. The motors are fitted with integrated thermal overload protection and have a moisture protection rating of IP 54.

Microprocessors

All units are supplied as standard complete with control panel. The microprocessor controls the following functions: control of the water temperature, antifreeze protection, compressor timing, compressor automatic starting sequence (For multiple compressors), alarm reset.

The control panel is supplied with display showing all operational icons. The microprocessor is set for automatic defrost (when operating in severe ambient conditions) and for summer/ winter change over (only for RV versions).

The control also manages the anti-legionella program, the integration with other heating sources (electric heaters, boilers, solar panels etc), the operation of a three port modulating valve (for diverting to DHW or heating) and both the heating circuit pump and the domestic hot water circuit pump. If required (available as an option), the microprocessor can be configured in order for it to connect to a site BMS system thus enabling remote control and management.

Electric enclosure

The enclosure is manufactured in order to comply with the requirements of the electromagnetic compatibility standards CEE EN60204. Access to electrical cabinet in quick and easy thanks to hinged panels. The following components are supplied as standard on all units: main switch, a sequence relay that disables the power supply in the event that the phase sequence is incorrect (scroll compressors can be damaged if they rotate in the wrong direction), thermal overloads (protection of pumps and fans), compressor fuses, control circuit automatic breakers, compressor contactors, fan contactors and pump contactors. The terminal board has volt free contacts for remote ON-OFF, Summer/ winter change over (heat pumps only) and general alarm.

Control and protection devices

All units are supplied with the following controls and protections: user water return temperature sensor, antifreeze protection temperature sensor installed on users water output, domestic hot water supply and return temperature sensors (only versions P2S), high pressure and low pressure automatic reset, compressor thermal protection, air fan, thermal protection, pressure transducer (used to optimize the defrost cycle and to adjust the fan speed depending on ambient conditions), flow switch. All units are also fitted with a temperature probe sensor with "Energy Saving" function, supplied in a separate plastic box, which can be used to stop the pump use during periods of stand-by, when the water temperature reaches the set point. Doing this the power consumption of the unit is strongly reduced.

User and recovery flow switch (P4U/P4S versions)

The flow utility is installed as standard on all units and disables the operation of the unit in case of abnormal water flow in the system. The flow switch is made of a blade system fitted in the flow of the water; it is combined with two permanent magnets that assess the amount of water in transit and, in function of the measured parameter, enable or not the operation of the unit.

Electronic expansion valve (VTEE)

The use of the electronic thermostatic valve is particularly suitable for units operating under very variable load conditions. The electronic expansion valve enables the maximum possible efficiency to be achieved by maximizing the evaporator heat exchange, minimizing the reaction time to load variations and optimizing the su-

perheat . The use of the electronic thermostatic valve is particularly suitable for units operating under very variable load conditions.

Versions

Version P4S

This is a four pipe version that can produce hot water for heating (HH version), hot and cold water for cooling and domestic hot water (only RV versions) in all operational modes using an independent water circuit. When cooling, DHW generation is by heat recovery. This unit is normally used with two pipe water based change-over systems with the DHW circuit being separate.

Version P4U

This is a four pipe version that provides a modern approach to four pipe water based systems. Instead of using a boiler and chiller, this unit can generate hot water in one circuit, cold water in the other circuit either individually or simultaneously. When operating in simultaneous mode the heating capacity is equal to the cooling duty plus the power input to the compressors. The operating efficiency in this mode is extremely high. Domestic hot water production for this version is not available.

Version RV

This version uses 2 hydraulic connections and is able to produce hot water in winter and cold water in summer. The unit is combined with a 2-pipe system.

SE Version

Standard efficiency version, according to current standard. Unit equipped with EC fans.

Version LS

This version includes the complete acoustic insulation of the unit with compressor jackets and insulating material made with high density media and the interposition of heavy bitumen layer.

P4U version

User water heating

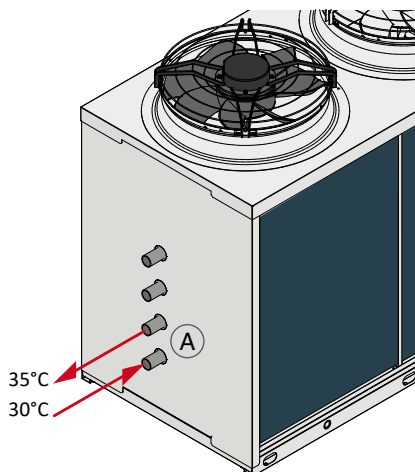

User water cooling

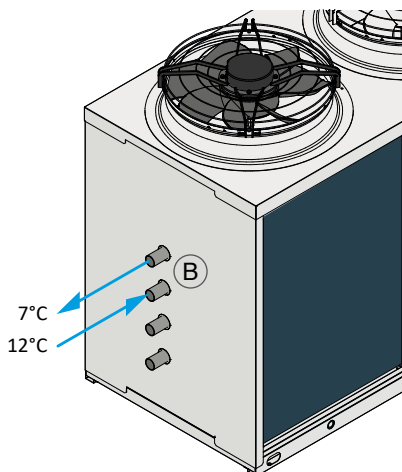

Simultaneous user Cooling + heating

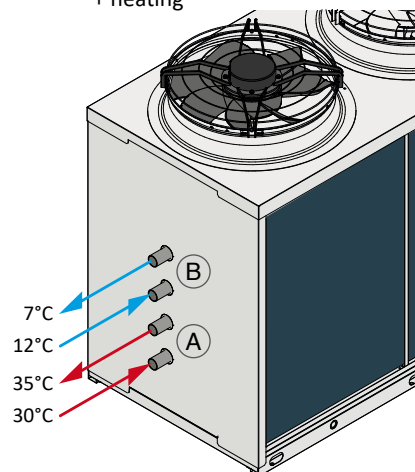

The above scheme is for illustrative purposes only. For the correct pipes placement, please refer to the units technical manual.

XL Super low noise version

All units in XL super low noise version are supplied, as standard, with the latest 'Floating Frame' technology that completely isolates the compressors from the main casing, thereby eliminating vibration and noise from this source. The 'Floating Frame' is a special vibration and acoustic damping system that consists of a base plate and acoustic enclosure that houses the compressors. The base plate is separated from the supporting frame of the unit by soft steel springs that have a high damping power. Within the enclosure, the compressors are mounted on rubber shock absorbers on the floating base plate. The enclosure is manufactured from galvanized steel sandwich panels that have a micro-perforated inner skin and a core of 30 mm thick, high density (25 kg/m³). The entire arrangement provides a double damping system and acoustic attenuation. The compressor refrigerant pipes are connected to the refrigerant circuit through "anaconda" flexible connections. Flexible connections are also used on the water pipework within the unit. The combination of these systems results in an overall noise reduction in the region of 5-7 dB(A).

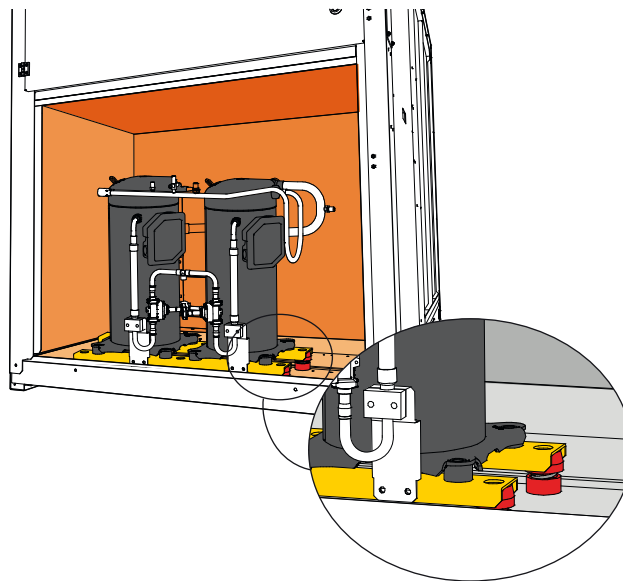

Operation limits

(SE versions)

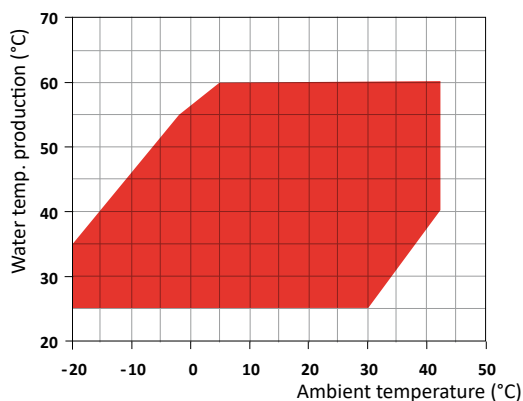

 Heating mode

(RV versions Only)

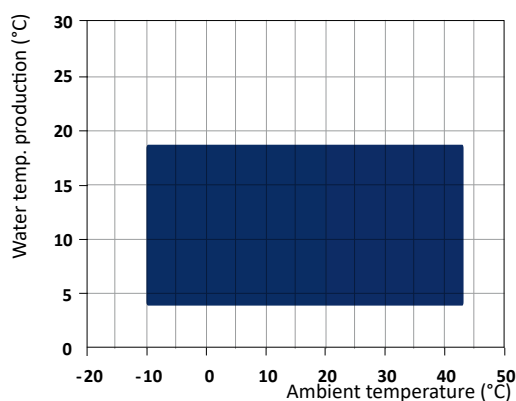

 Cooling mode

P4S version

User water heating

User water cooling

Domestic hot water production (D.H.W.)

User water cooling + D.H.W. production

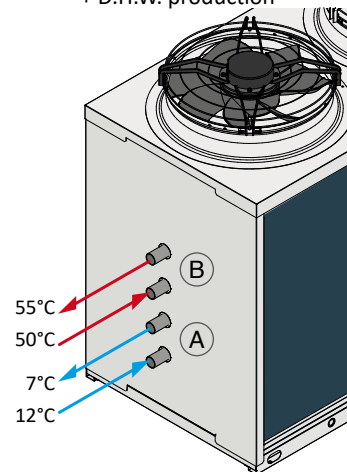
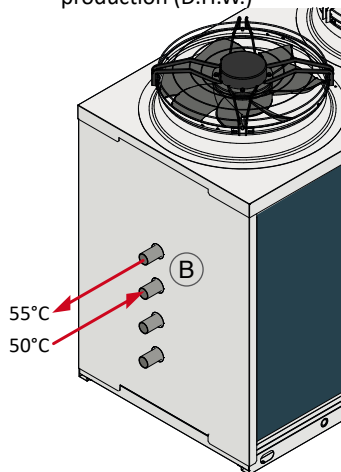
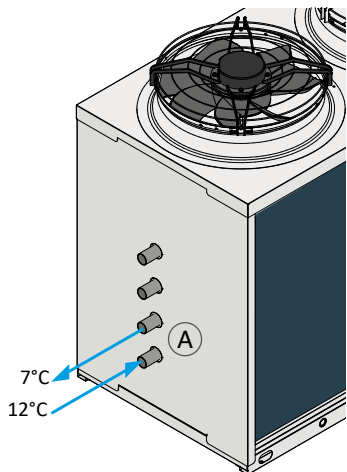
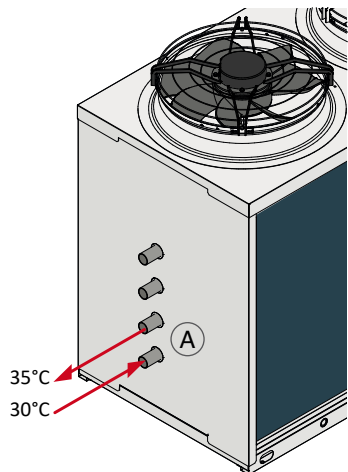

The above scheme is for illustrative purposes only. For the correct pipes placement, please refer to the units technical manual.

LHi SE/HH-RV	P4S/P4U	532	632	742	862	912	1052	1222
Flow switch		●	●	●	●	●	●	●
“Floating frame” Technology - XL Version		●	●	●	●	●	●	●
E.C. fans - SE versions	VECE	●	●	●	●	●	●	●
Condensate discharge drip tray with antifreeze heater	BRCA	○	○	○	○	○	○	○
Antifreeze kit for 4 pipe units	RAEV4	○	○	○	○	○	○	○
Electronic soft starter	DSSE	○	○	○	○	○	○	○
Serial interface card RS485	INSE	●	●	●	●	●	●	●
Rubber anti-vibration mountings	KAVG	○	○	○	○	○	○	○
Remote control panel	PCRL	○	○	○	○	○	○	○
Electronic expansion valve	VTEE	●	●	●	●	●	●	●
Power factor correction system	RICO	○	○	○	○	○	○	○
Power factor correction system with soft starter	RICSS	○	○	○	○	○	○	○
Spring vibration dampers	KAVM	○	○	○	○	○	○	○
Coil protection grid	GBPE	○	○	○	○	○	○	○
Shut-off valve on compressor discharging side	RDCO	○	○	○	○	○	○	○
Shut-off valve on compressor suction side	RHCO	○	○	○	○	○	○	○
Hydraulic kit with one inverter pump	A1VSU	○	○	○	○	○	○	○
Hydraulic kit with one pump without tank	A1NTU	○	○	○	○	○	○	○
Hydraulic kit with one higher available pressure pump	A1HPU	○	○	○	○	○	○	○
Hydraulic kit with two pumps without tank	A2NTU	○	○	○	○	○	○	○
Hydraulic kit with tank and one inverter pump	A1VVU	○	○	○	○	○	○	○
Hydraulic kit with one pump with tank	A1ZZU	○	○	○	○	○	○	○
Hydraulic kit with tank and one higher available pressure pump	A1HHU	○	○	○	○	○	○	○
Hydraulic kit with two pumps with tank	A2ZZU	○	○	○	○	○	○	○
Buffer tank and pump for internal loop	BUF4A	○	○	○	○	○	○	○
Hydraulic kit with one pump for heat recovery	A1NTR	○	○	○	○	○	○	○
Hydraulic kit with higher available pressure pump for heat recovery	A1HPR	○	○	○	○	○	○	○
Hydraulic kit with two pump for heat recovery	A2NTR	○	○	○	○	○	○	○
Antifreeze kit in combination with A1VSU / A1NTU / A1HPU *	KPU1	○	○	○	○	○	○	○
Antifreeze kit in combination with A2NTU *	KPU2	○	○	○	○	○	○	○
Antifreeze kit in combination with pump and buffer tank *	KPSU1	○	○	○	○	○	○	○
Antifreeze kit in combination with pumps and buffer tank *	KPSU2	○	○	○	○	○	○	○
Antifreeze kit in combination with A1NTR / A1HPR	KPR1	○	○	○	○	○	○	○
Antifreeze kit in combination with A2NTR	KPR2	○	○	○	○	○	○	○

* Includes accessory RAEV2

● Standard ○ Optional – Not available

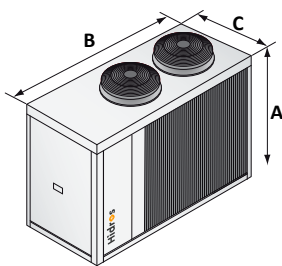

SE/LS 532
SE/XL 532

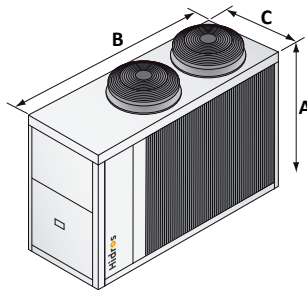

SE/LS 632 - 742
SE/XL 632

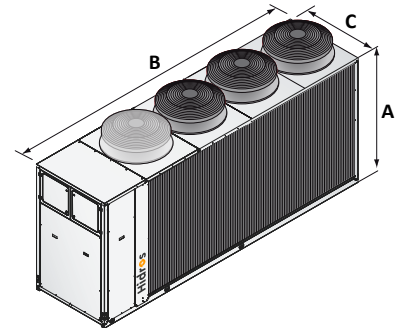

SE/LS 862 - 912 - 1052 - 1222
SE/XL 742 - 862 - 912 - 1052 - 1222

		532	632	742	862	912	1052	1222
A (mm)	SE/LS	1690	1840	1840	1840	1840	1840	1840
B (mm)	SE/LS	2400	2905	2905	3905	3905	3905	3905
C (mm)	SE/LS	1145	1145	1145	1145	1145	1145	1145
kg	SE/LS	810	940	950	970	1270	1360	1410
A (mm)	SE/XL	1690	1840	1840	1840	1840	1840	1840
B (mm)	SE/XL	2400	2905	3905	3905	3905	3905	3905
C (mm)	SE/XL	1145	1145	1145	1145	1145	1145	1145
kg	SE/XL	830	960	970	990	1290	1380	1430

LHi SE/HH-RV	P4S/P4U	1534	1654	1854	1964	2254	2554
Flow switch		●	●	●	●	●	●
“Floating frame” Technology - XL Version		–	–	–	–	–	–
E.C. fans - SE versions	VECE	●	●	●	●	●	●
Condensate discharge drip tray with antifreeze heater	BRCA	○	○	○	○	○	○
Antifreeze kit for 4 pipe units	RAEV4	○	○	○	○	○	○
Electronic soft starter	DSSE	○	○	○	○	○	○
Serial interface card RS485	INSE	●	●	●	●	●	●
Rubber anti-vibration mountings	KAVG	○	○	○	○	○	○
Remote control panel	PCRL	○	○	○	○	○	○
Electronic expansion valve	VTEE	●	●	●	●	●	●
Power factor correction system	RICO	○	○	○	○	○	○
Power factor correction system with soft starter	RICSS	○	○	○	○	○	○
Spring vibration dampers	KAVM	○	○	○	○	○	○
Coil protection grid	GBPE	○	○	○	○	○	○
Shut-off valve on compressor discharging side	RDCO	○	○	○	○	○	○
Shut-off valve on compressor suction side	RHCO	○	○	○	○	○	○
Hydraulic kit with one inverter pump	A1VSU	○	○	○	○	○	○
Hydraulic kit with one pump without tank	A1NTU	○	○	○	○	○	○
Hydraulic kit with one higher available pressure pump	A1HPU	○	○	○	○	○	○
Hydraulic kit with two pumps without tank	A2NTU	○	○	○	○	○	○
Hydraulic kit with tank and one inverter pump	A1VVU	○	○	○	○	○	○
Hydraulic kit with one pump with tank	A1ZZU	○	○	○	○	○	○
Hydraulic kit with tank and one higher available pressure pump	A1HHU	○	○	○	○	○	○
Hydraulic kit with two pumps with tank	A2ZZU	○	○	○	○	○	○
Buffer tank and pump for internal loop	BUF4A	○	○	○	○	○	○
Hydraulic kit with one pump for heat recovery	A1NTR	○	○	○	○	○	○
Hydraulic kit with higher available pressure pump for heat recovery	A1HPR	○	○	○	○	○	○
Hydraulic kit with two pump for heat recovery	A2NTR	○	○	○	○	○	○
Antifreeze kit in combination with A1VSU / A1NTU / A1HPU *	KPU1	○	○	○	○	○	○
Antifreeze kit in combination with A2NTU *	KPU2	○	○	○	○	○	○
Antifreeze kit in combination with pump and buffer tank *	KPSU1	○	○	○	○	○	○
Antifreeze kit in combination with pumps and buffer tank *	KPSU2	○	○	○	○	○	○
Antifreeze kit in combination with A1NTR / A1HPR	KPR1	○	○	○	○	○	○
Antifreeze kit in combination with A2NTR	KPR2	○	○	○	○	○	○

● Standard ○ Optional – Not available

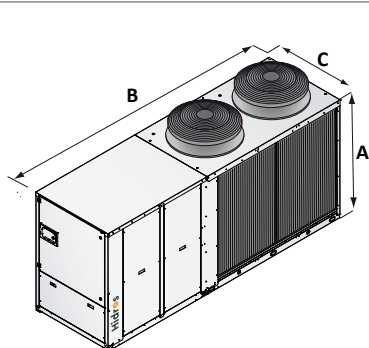

SE/LS 1534
SE/XL 1534

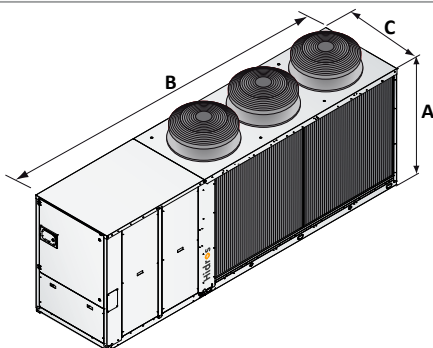

SE/LS 1654 - 1854 - 1964
SE/XL 1654 - 1854 - 1964

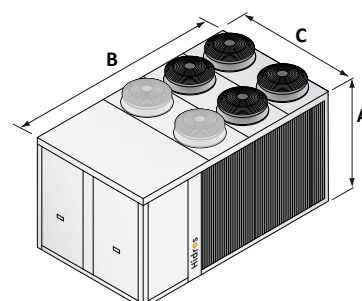

SE/LS 2254 - 2554
SE/XL 2254 - 2554

		1534	1654	1854	1964	2254	2554
A (mm)	SE/LS	1890	1890	1890	1890	2350	2350
B (mm)	SE/LS	3695	4695	4695	4695	4205	4205
C (mm)	SE/LS	1145	1145	1145	1145	2190	2190
kg	SE/LS	1460	1810	1830	2130	2680	2720
A (mm)	SE/XL	1890	1890	1890	1890	2350	2350
B (mm)	SE/XL	3695	4695	4695	4695	4205	4205
C (mm)	SE/XL	1145	1145	1145	1145	2190	2190
kg	SE/XL	1480	1830	1850	2150	2700	2740