

NSA

Swimming pool dehumidifiers



NSA with FARC option



Series NSA dehumidifier are expressly designed for use in swimming pools where humidity should be closely controlled in order to guarantee optimal comfort. These units are intended to be installed in a technical room close to the swimming pool. A centrifugal fan with high available static pressure allows unit connection to ductworks, both for air suction and discharge. This series comprises 6 basic models which cover a capacity range from 263 to 940 l/24h.

Temperature and humidity probes are accessories supplied on request.

Versions

The series includes 6 models with air flows from 3500 to 8500 m³/h.

NSA		275	355	455	555	755	955
Moisture removed at 30°C - 80%	l/24h	263,1	340,2	418,8	566,8	751,1	939,3
Moisture removed at 30°C - 60%	l/24h	185,1	262,3	336,3	425,0	596,4	759,7
Moisture removed at 27°C - 60%	l/24h	161,4	233,5	302,0	375,7	534,3	680,3
Moisture removed at 20°C - 60%	l/24h	111,4	168,5	223,9	267,1	391,0	501,0
Total cooling cap. (30°C-80% - 35°C ext)	kW	12,93	16,96	19,83	25,57	35,56	43,17
Sensible cooling cap. (30°C-80% - 35°C ext)	kW	4,48	5,91	7,20	8,80	12,45	15,50
Nominal input power at 30°C-80%	kW	4,38	5,69	9,04	10,09	15,52	20,01
Maximum input power	kW	6,3	7,8	9,8	14,0	18,9	22,9
Maximum input current	A	11,0	14,0	18,2	25,6	34,4	44,1
Peak current	A	46,0	59,0	77,0	93,0	114,0	159,0
Air Flow indoor unit	m ³ /h	3500	4200	4200	5500	7000	8500
Air Flow outdoor unit	m ³ /h	7500	7100	6700	15000	14200	21300
Available static pressure	Pa	50	50	50	50	50	50
Refrigerant		R410A	R410A	R410A	R410A	R410A	R410A
Refrigerant charge	kg	3,00	2,50	2,50	9,00	8,00	8,00
Global warming potential (GWP)		2088	2088	2088	2088	2088	2088
Equivalent CO ₂ charge	t	6,26	5,22	5,22	18,79	16,70	16,70
Sound power ⁽¹⁾	dB(A)	70	71	71	73	73	73
Sound pressure ⁽²⁾	dB(A)	63	64	64	66	66	66
Sound pressure ⁽³⁾	dB(A)	39	41	40	40	42	43
Power supply	V/Ph/Hz	400/3+N/50	400/3+N/50	400/3+N/50	400/3+N/50	400/3+N/50	400/3+N/50

Performances are calculated with low fan speed and are referred to the following conditions:

(1) Sound Power level according to ISO 9614 fan with available static pressure 50 Pa.

(2) Sound pressure level measured at 1 mt from the unit in free field conditions according to ISO 9614. fan with available static pressure 50 Pa.

(3) Sound pressure level measured at 10 mt from the unit in free field conditions according to ISO 9614. fan with available static pressure 50 Pa.

Plant scheme

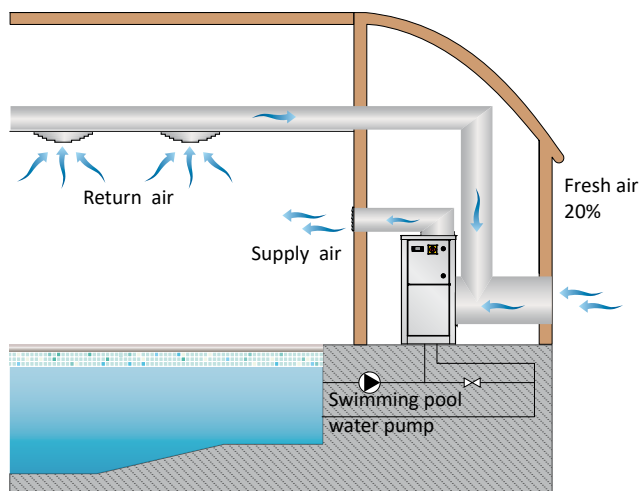

Operation limits

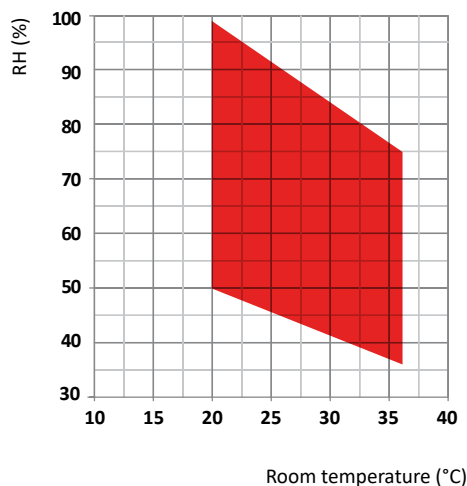

Frame

All units are made from hot-galvanised thick sheet metal, painted with polyurethane powder enamel at 180°C to ensure the best resistance against the atmospheric agents. The frame is self-supporting with removable panels. All screws and rivets are in stainless steel. The colour of the units is RAL 9018.

Refrigerant circuit

The refrigerant gas used in these units is R410A. The refrigerant circuit is made by using international primary brands components and according to ISO 97/23 concerning welding procedures.

The refrigerant circuit includes: sight glass, filter drier, thermal expansion valve with external equalizer, Schrader valves for maintenance and control, pressure safety device (according to PED regulation).

Compressor

The compressors are rotative type, with thermal overload protection by a klixon embedded in the motor winding. The compressor is mounted on rubber vibration dampers and it is supplied, on request, with sound-proof cover (optional) to reduce noise emission. The inspection is possible through the frontal panel of the unit that allows the maintenance of the compressor.

Condenser and evaporator

Condensers and evaporators are made of copper pipes and aluminium fins. All evaporators are painted with epoxy powders to prevent corrosion problem due to their use in aggressive environments. The diameter of the copper pipes is 3/8" and the thickness of the aluminium fins is 0,1 mm. The tubes are mechanically expanded into the aluminium fins to improve the heat exchange factor. The geometry of these heat exchangers guarantees a low air side pressure drop and then the use of low rotation (and low noise emission) fans. All units are supplied, standard, with a powder coated steel drip tray and all evaporators are supplied with a temperature sensor used as defrost probe.

Supply fan

The fans are made of galvanized steel, centrifugal type. It is statically and dynamically balanced and supplied. The electric motors are directly connected to the fan; they are all at 2 speeds, with integrated thermal protection. The protection class of the motors is IP 54. The fans are painted with epoxy powder to prevent problems when used in aggressive environments.

Air filter

It is made of synthetic filtering media, undulated type, without electro-static charge; they are all removable for differential disposal, ePM10 50% according to UNI EN ISO 16890:2017.

Microprocessor

All units are supplied standard with microprocessor controls. The microprocessor controls the following functions: compressor timing, automatic defrost cycles, alarms. An appropriate LCD display shows the operation mode of the unit, set point and alarms.

Electric box

The electric switch board is made according to electromagnetic compatibility norms CEE 2014/35 and 2014/30. The accessibility to the board is possible after removing the front panel of the unit and the OFF positioning of the main switch. The following components are also standard installed: main switch, magnetic-thermal

switches (as a protection fans and compressors), control circuit automatic breakers, compressor contactors, fan contactors. The terminal board is supplied with voltage free contacts for remote ON-OFF and general alarm.

Control and protection devices

All units are supplied with the following control and protection devices: antifreeze protection sensor, high pressure switch with manual reset, low pressure switch with automatic reset, high pressure safety valve, compressor thermal overload protection, fans thermal overload protection.

Test

All the units are fully assembled and wired at the factory, carefully evacuated and dried after leak tests under pressure and then charged with refrigerant R410A.

They are all fully operational tested before shipment. They all conform to European Directives and are individually marked with the CE label and provided with Conformity Declaration.

Accessories

CANA - Delivery flange for channel connection

Press-folded rectangular flange for connection to the ducts and installed on the fan expulsion mouth.

FARC - Air filter with frame for ducted installation

Complete with efficiency air filter which can be removed by the side and frame for ducted installation.

HBSL - HOEL - Electric heater 9kW/18kW

The electric heater kit is in aluminium and is used to integrate the unit heating capacity. The kit is composed of an on-off double safety thermostat without capacity steps.

HOWA - Hot water coil

The heat exchanger is made of copper pipes and aluminium fins. The diameter of the copper pipes is 3/8" and the thickness of the aluminium fins is 0,1 mm. The tubes are mechanically expanded into the aluminium fins to improve the heat exchange factor.

HYGR- Remote mechanical hygostat + thermostat

To be installed on the wall, it is supplied with a regulation knob and working range from 30% to 100% with precision of 3%.

INOX - Stainless steel frame

It's used to ensure the best resistance against the atmospheric agents and the operation in aggressive environments. The frame is made of stainless steel AISI 304, self-supporting with removable panels to facilitate inspection and maintenance of internal components. All screws and rivets are in stainless steel.

KAVG - Rubber vibration dampers

To be installed beneath the unit base and the ground to avoid the transmission of vibrations (and the noise) to the building.

KIWA - 3 Way on/off valve

It is used to control the waterflow in the coil. The valve is directly controlled from the unit microprocessor.

LSMC - Compressor soundproofing

Compressor jackets with high density insulation material.

RP01 - Partial heat recovery

The unit is fitted with a Coaxial type heat exchanger suitable for chlorinated water. The internal pipe is manufactured from Cupronickel with the external pipe being made from Copper. The chlorinated water flows within the internal pipe whilst the refrigerant gas passes through the gap between the internal and external pipes. The Cupronickel internal pipe is manufactured with a special profile that generates turbulent flow within the refrigerant gas thus increasing the heat exchange factor, the thermal efficiency and reducing the dimensions. The heat exchanger is designed to recover approx. 20% of the thermal capacity generated by the unit.

V1CE - E.C. supply fan

The supply fan is a high performance centrifugal type, double inlet forward curved blades, directly coupled to the electric motor. The

fan wheel and the scroll are made from hot galvanised thick sheet metal, painted with polyurethane powders, to ensure the best resistance against aggressive environments. The electric motor is a high efficiency DC brushless type with external rotor, to guarantee an ideal cooling of the windings and the absence of power lost due to pulleys and belt transmission. The fan is statically and dynamically balanced class 6,3 according to ISO1940. The electric motor has a separate electronic commutator (driver) and a speed modulation 0-10V, integrated PFC, burn out thermal protection (in case of considerable reduction of the power supply), protection degree IP54, serial interface card with modbus protocol RTU.

NSA		275	355	455	555	755	955
Main switch		●	●	●	●	●	●
Supply flange	CANA	○	○	○	○	○	○
Air filter with frame for ducted installation	FARC	○	○	○	○	○	○
A.C. fan with available static pressure up to 150 Pa	HAPS	○	○	○	○	○	○
Electric heater kit 18kW	HBSEL	-	-	-	○	○	○
Electric heater kit 9 kW	HOEL	○	○	○	○	○	○
Hot water coil	HOWA	○	○	○	○	○	○
Remote mechanical hygrostat	HYGR	○	○	○	○	○	○
Stainless steel frame	INOX	○	○	○	○	○	○
Rubber vibration dampers	KAVG	○	○	○	○	○	○
3 Way on/off valve	KIWA	○	○	○	○	○	○
Compressor soundproofing	LSMC	○	○	○	○	○	○
Partial heat recovery Cu-Ni made	RP01	○	○	○	○	○	○
High efficiency E.C. fans ≤ 300 Pa	V1CE	○	○	○	○	○	○

● Standard, ○ Optional, - Not Available.

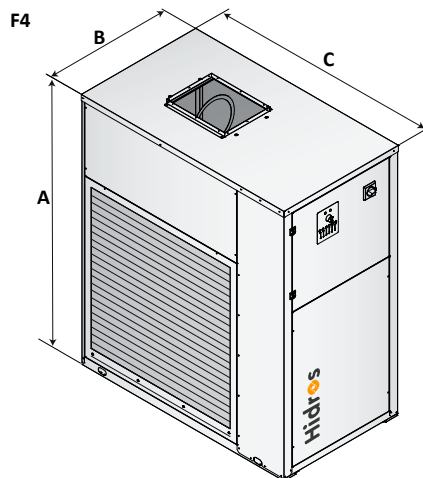
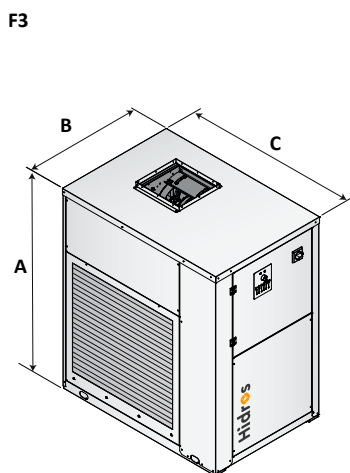

Possible configurations

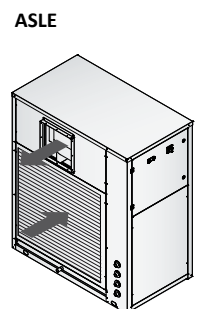
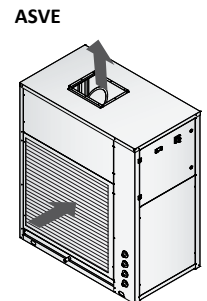

Mod.	Frame	A (mm)	B (mm)	C (mm)	kg
275	F3	1261	758	1118	204
355	F3	1261	758	1118	208
455	F3	1261	758	1118	212
555	F4	1753	858	1519	412
755	F4	1753	858	1519	420
955	F4	1753	858	1519	427