

DEHUMIDIFIERS FOR RADIANT COOLING SYSTEM

**FH**  
SERIE



R134a

TECHNICAL MANUAL

Incorporated in this document are the following:

- Declaration of conformity
- Technical manual
- Dimensional drawing



RETAIN FOR FUTURE REFERENCE

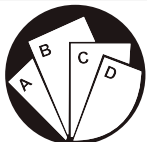

Multiple instructions:  
Consult the specific part



Read and understand  
the instructions before  
undertaking any work on  
the unit

Reproduction, data storage and transmission, even partial, of this publication, in any form, without the prior written authorisation of HIDROS S.p.A., is prohibited. HIDROS S.p.A. can be contacted for all inquiries regarding the use of its products.

HIDROS S.p.A. follows a policy of continuous product development and improvement and reserves the right to modify specifications, equipment and instructions regarding use and maintenance at any time, without notice.

## **Declaration of conformity**

We declare under our own responsibility that the below equipment complies in all parts with the CEE and EN directives.

The declaration of conformity is enclosed to the technical booklet enclosed with the unit. The unit contains fluorinated greenhouse gases.

## INDICE

1. INTRODUCTION .....	5
1.1 Preliminary information .....	5
1.2 Aim and content of the manual .....	5
1.3 How to store this manual .....	5
1.4 Manual updates .....	5
1.5 How to use this manual .....	5
1.6 Potential risks .....	6
1.7 General description of symbols used .....	7
1.8 Safety symbols used .....	8
1.9 Limitations and prohibited use .....	8
1.10 Unit identification .....	9
2. SAFETY .....	10
2.1 Warning re potentially hazardous toxic substances .....	10
2.2 Refrigerant handling .....	10
2.3 Prevention of inhalation of high vapor concentrations .....	10
2.4 Procedures in the event of accidental release of refrigerant .....	11
2.5 Main Toxicological information on the type of refrigerant used .....	11
2.6 First aid measures .....	11
3. TECHNICAL CHARACTERISTICS .....	12
3.1 Unit description .....	12
3.2 Versions .....	13
3.3 Accessories .....	13
3.4 Unit components .....	14
3.5 Refrigerant circuit layout .....	14
3.6 Technical data .....	16
3.7 Hydraulic circuit pressure drops .....	16
3.8 Operation limits .....	17
3.9 Sound data .....	17
3.10 Safety devices .....	18
3.11 Electric data .....	18
4. INSTALLATION .....	18
4.1 General safety guidelines and use of symbols .....	18
4.2. Health and safety Considerations .....	19
4.3 Personal protective equipment .....	19
4.4 Inspection .....	19
4.5 Storage .....	20
4.6 Unpacking .....	20
4.7 Lifting and handling .....	20
4.8 Location and minimum technical clearances .....	20
4.9 Assembly of the counter and its installation .....	22
4.10 Installation of dehumidifier into the formwork .....	23
4.11 Condensate draining connections .....	23
4.12 Water coil hydraulic connection .....	23
4.13 How to vent the unit .....	24
4.14 Ductwork unit connection .....	24
4.15 FH standard version: Remote mechanical hygostat connection (HYGR.20) .....	25
4.16 FH- WZ version : Remote mechanical hygostat connection (HYGR.30) .....	25
4.17 Filter extraction .....	26
4.18 Supply and return grilles installation .....	26
4.19 Electric connections: preliminary safety information .....	27
4.20 Electrical data .....	28
4.21 Electrical connections .....	28
5. UNIT START UP .....	30
5.1 Preliminary checks .....	30
5.2 Control panel .....	30

6. USE .....	31
6.1 Unit switch on and first start up.....	31
6.2 Stop .....	31
6.3 Stand-by .....	31
6.4 Displaying during an alarm .....	31
7. MAINTENANCE OF THE UNIT .....	32
7.1 General warnings.....	32
7.2 Drive access .....	33
7.3 Scheduled maintenance .....	33
7.4 Periodical checks.....	33
7.5 Refrigerant circuit repair .....	35
8. DECOMMISSIONING.....	36
8.1 Disconnect the unit .....	36
8.2 Disposal, recovery and recycling.....	36
8.3 RAEE Directive (only UE).....	36
9. DIAGNOSIS AND TROUBLESHOOTING .....	37
9.1 Fault finding .....	37
10.DIMENSIONAL DRAWINGS .....	38

## 1. INTRODUCTION

### 1.1 Preliminary information

Reproduction, storage or transmission of any part of this publication in any form, without the prior written consent of the Company, is prohibited.

The unit to which these instructions refer, is designed to be used for the the purposes described and to be operated in accordance with these instructions.

The Company will not be liable for claims for damage caused to persons, animals, material goods or property caused by improper installation, adjustment and maintenance or improper use. Any use not specified in this manual is prohibited.

This document is intended to provide information only and does not form a contract with third parties.

The Company pursues a policy of constant improvement and development of its products and therefore reserves the right to change the specifications and the documentation at any time, without notice and without obligation to update existing equipment.

### 1.2 Aim and content of the manual

These instructions are intended to provide the information required for the selection, installation, use and maintenance of the unit.

They have been prepared in accordance with the European Union laws and with the technical standards in force at the date of issue of the instructions.

The instructions contain all the necessary information to prevent any reasonably foreseeable misuse.

### 1.3 How to store this manual

The manual must be kept in a suitable place with easy access for users and operators, protected from dust and damp.

The manual must always accompany the unit during the entire life cycle of the same and therefore must be transferred to any subsequent user.

### 1.4 Manual Update

It is recommended that the manual is updated to the latest revision available.

If updates are sent to the customer they must be added to this manual.

The latest information regarding the use of its products is available by contacting the Company.

### 1.5 How to use this manual



The manual is an integral part of the unit.

Users or operators must consult the manual before performing any operation and especially so when transporting, handling, installing, maintaining, or dismantling the unit in order to eliminate uncertainty and reduce risk.



In these instructions symbols have been used (described in the following paragraphs) to draw the attention of operators and users to the operations that have a higher risk and which must be performed safely.

## 1.6 Potential Risks

Whilst the unit has been designed to minimize any risk posed to the safety of people who will interact with it, it has not been technically possible to eliminate completely the causes of risk. It is therefore necessary to refer to the requirements and symbolism below:

LOCATION OF RISK	POTENTIAL RISK	METHOD OF INJURY	PRECAUTIONS
Thermal heat exchangers.	Small stab wounds.	Contact	Avoid any contact, use protective gloves.
Fan and fan grilles.	Cuts, eye damage, broken bones.	Insertion of sharp objects through the grid while the fans are operating.	Never put objects through the protection grilles.
Internal component: compressors and discharge pipes	Burns.	Contact	Avoid any contact, use protective gloves.
Internal component: electric cables and metallic parts	Electrocution, severe burns.	Defect in the supply cable insulation, live metallic parts.	Adequate protection of power cables, ensure correct earthing of all metal parts.
External to unit: unit enclosure	Poisoning, severe burns.	Fire due to short circuit or overheating of the supply cable external to unit.	Size cables and mains protection system in accordance with iee regulations.
Low pressure safety valve.	Poisoning, severe burns.	High evaporating pressure causing a refrigerant discharge during maintenance.	Carefully check the evaporating pressure during the maintenance operations.
High pressure safety valve.	Poisoning, severe burns, hearing loss.	Activation of the high pressure safety valve with the refrigerant circuit open.	If possible, do not open the refrigerant circuit valve; carefully check the condensing pressure; use all the personal protective equipment required by law.
Entire unit	External fire	Fire due to natural disasters or combustions of elements nearby unit	Provide the necessary fire-fighting equipment
Entire unit	Explosion, injuries, burns, poisoning, folgoramento for natural disasters or earthquake.	Breakages, failures due to natural disasters or earthquake	Plan the necessary precautions both electrical (suitable differential magneto and electrical protection of the supply lines; greatest care during the connections of the metal parts), and mechanical (special anchors or seismic vibrations to prevent breakages or accidental falls).

## 1.7 General Description of Symbols Used

Safety symbols combined in accordance with ISO 3864-2:



### **BANNED**

A black symbol inside a red circle with a red diagonal indicates an action that should not be performed.



### **WARNING**

A black graphic symbol added to a yellow triangle with black edges indicates danger.



### **ACTION REQUIRED**

A white symbol inserted in a blue circle indicates an action that must be done to avoid a risk.

Safety symbols combined in accordance with ISO 3864-2:



The graphic symbol "warning" is qualified with additional safety information (text or other symbols).

## 1.8 Safety symbols used



### GENERAL RISK

Observe all signs placed next to the pictogram. The failure to follow directions may create a risk situation that may be injurious to the user.



### ELECTRICAL HAZARD

Observe all signs placed next to the pictogram. The symbol indicates components of the unit and actions described in this manual that could create an electrical hazard.



### MOVING PARTS

The symbol indicates those moving parts of the unit that could create risk.



### HOT SURFACES

The symbol indicates those components with high surface temperature that could create risks.



### SHARP SURFACES

The symbol indicates components or parts that could cause stab wounds.



### EARTH CONNECTION

The symbol identifies Earthing connection points in the unit.



### READ AND UNDERSTAND THE INSTRUCTIONS

Read and understand the instructions of the machine before any operations.



### RECOVER OR RECYCLE MATERIAL

## 1.9 Limitations and prohibited use

The machine is designed and built exclusively for the uses described in "Limitations of use" of the technical manual. Any other use is prohibited because it may pose a potential risk to the health of operators and users.



The unit is not suitable for operations in environments:

- excessively dusty or potentially explosive atmospheres;
- where there are vibrations;
- where there are electromagnetic fields;
- where there are aggressive atmospheres



### 1.10 Unit identification

Each unit has a rating plate that provides key information regarding the machine. The rating plate may differ from the one shown below as the example is for a standard unit without accessories. For all electrical information not provided on the label, refer to the wiring diagram. A facsimile of the label is shown below:

		Manufacturer: PD322111	
<b>1FH0.025A-2E</b> Modello <i>Model</i>		<b>123456</b> Matricola <i>Serial number</i>	
<b>2</b> Categoria PED <i>PED Category</i>		<b>8/2017</b> Data di fabbricazione <i>Manufacture date</i>	
<b>R134A</b> Tipo refrigerante <i>Refrigerant type</i>	<b>2</b> Gruppo fluido <i>Fluid group</i>	<b>1430</b> GWP	
<b>C1 0,25 Kg</b> Carica refrigerante <i>Refrigerant charge</i>	<b>C2</b> <b>C3</b> <b>C4</b>	<b>0,36 ton</b> CO <sub>2</sub> Equivalente <i>CO<sub>2</sub> Equivalente</i>	
<b>230V-1ph-50Hz</b> Tensione-Fasi-Frequenza <i>Voltage-Phases-Frequency</i>		<b>2,80 A</b> F.L.A. (A)	<b>0,50 kW</b> F.L.I. (kW)
LATO BASSA PRESSIONE LOW PRESSURE SIDE		LATO ALTA PRESSIONE HIGH PRESSURE SIDE	
<b>10 bar</b> PS		<b>20,6 bar</b> PS	
<b>Min</b> <b>-30 °C</b> Temperatura di progetto <i>Design temperature</i>	<b>Max</b> <b>+130 °C</b> Temperatura di progetto <i>Design temperature</i>	<b>Min</b> <b>-30 °C</b> Temperatura di progetto <i>Design temperature</i>	<b>Max</b> <b>+130 °C</b> Temperatura di progetto <i>Design temperature</i>
<b>45 Kg</b> Peso a vuoto <i>Weight</i>			
Contiene gas fluorurati ad effetto serra disciplinati dal protocollo di Kyoto Contains fluorinated greenhouse gasses covered by the Kyoto protocol			



The product label should never be removed from the unit.

## 2. SAFETY

### 2.1 Warning re potentially hazardous toxic substances

#### 2.1.1 Identification of the Type of Refrigerant Fluid Used: R134a:

Tetrafluoroethane (HFC134a) 100% by weight CAS No.: 000811-97-2

#### 2.1.2 Identification of the Type of Oil Used.

The lubricant used is polyester oil. Please refer to the information provided on the compressor data plate.



For further information regarding the characteristics of the refrigerant and oil used, refer to the safety data sheets available from the refrigerant and oil manufacturers.

Main Ecological Information Regarding the Types of refrigerants Fluids used.



**ENVIRONMENTAL PROTECTION** : Read the ecological information and the following instructions carefully.

#### 2.1.3 Persistence and degradation

The refrigerants used decompose in the lower atmosphere (troposphere) relatively quickly. The decomposed products are highly dispersible and therefore have a very low concentration. They do not influence the photochemical smog which is not among the VOC volatile organic compounds (as stipulated in the guidelines to the UNECE). The constituent refrigerants of R407C (R32, R125 and R134a), do not damage the ozone layer. These substances are regulated under the Montreal Protocol (revised 1992) and regulations EC no. 2037/200 of 29 June 2000.

#### 2.1.4 Effects of discharges

Discharges into the atmosphere of this product does not cause a long-term contamination.

#### 2.1.5 Exposure controls and personal protection

Wear protective clothing and gloves, protect your eyes and face

#### 2.1.6 Professional exposure limits

R134A

HFC-134a      TWA 1000 ppm

## 2.2 Refrigerant handling



Users and maintenance personnel must be adequately informed about the possible risks of handling potentially toxic substances. Failure to follow such instructions can cause damage to personnel or to the unit.

## 2.3 Prevent inhalation of high vapor concentration

Atmospheric concentrations of refrigerant must be minimized and kept to a level that is below the occupational exposure limit. Vapor is heavier than air and can form dangerous concentrations near the ground where the ventilation rate is lower. Always ensure adequate ventilation. Avoid contact with open flames and hot surfaces as this can cause toxic and irritating decomposition products to form. Avoid contact between liquid refrigerant and the eyes or skin.

## 2.4 Procedures to be adopted in the event of accidental release of refrigerant

Ensure suitable personal protection (especially respiratory protection) during cleaning operations.

If deemed safe, isolate the source of the leak. If the leakage is small and if adequate ventilation is provided, allow the refrigerant to evaporate. If the loss is substantial ensure that measures are taken to adequately ventilate the area.

Contain spilled material with sand, earth or other suitable absorbent material.

Do not allow the refrigerant to enter drains, sewers or basements, as pockets of vapor can form.

## 2.5 Main Toxicological Information Regarding the Type of refrigerant used

### 2.5.1 Inhalation

A high atmospheric concentration can cause anaesthetic effects with possible loss of consciousness. Prolonged exposure may lead to irregular heartbeat and cause sudden death. Higher concentrations may cause asphyxia due to the reduced oxygen content in the atmosphere.

### 2.5.2 Contact with skin

Splashes of nebulous liquid can produce frostbite. Probably not hazardous if absorbed through the skin. Repeated or prolonged contact may remove the skin's natural oils, with consequent dryness, cracking and dermatitis.

### 2.5.3 Contact with eyes

Splashes of liquid may cause frostbite.

### 2.5.4 Ingestion

While highly improbable, may produce frostbite.

## 2.6 First Aid Measures



Adhere scrupulously to the warnings and first aid procedures indicated below.

### 2.6.1 Inhalation

Move the person away from the source of exposure, keep him/her warm and let him/her rest. Administer oxygen if necessary. Attempt artificial respiration if breathing has stopped or shows signs of stopping. If the heart stops, perform external heart massage. Seek medical assistance.

### 2.6.2 Contact with skin

In case of contact with skin, wash immediately with lukewarm water. Thaw tissue using water. Remove contaminated clothing. Clothing may stick to the skin in case of frostbite. If irritation, swelling or blisters appear, seek medical assistance.

### 2.6.3 Contact with eyes

Rinse immediately using an eyewash or clean water, keeping eyelids open, for at least ten minutes. Seek medical assistance.

### 2.6.4 Ingestion

Do not induce vomiting. If the injured person is conscious, rinse his/her mouth with water and make him/her drink 200-300ml of water. Seek immediate medical assistance.

### 2.6.5 Further medical treatment

Treat symptoms and carry out support therapy as indicated. Do not administer adrenaline or similar sympathomimetic drugs following exposure, due to the risk of cardiac arrhythmia.

### 3. TECHNICAL CHARACTERISTICS

#### 3.1 Unit description

The dehumidifiers FH series are built vertically, equipped with robust galvanised steel frame, properly designed to operate in combination with radiant cooling systems. The units have been designed to ensure the dehumidification of the air under conditions of air thermally neutral, ie at the same temperature at which they levy it, in conditions of cooled air (only for versions WZ), managing very small air flow thus avoiding uncomfortable drafts typical of traditional air conditioning.

The units, can operate even without pre and post cooling coils, this option could be very useful in middle seasons when it is necessary to dry but the air conditioning system is not in operation.

All units are fully in compliance with the European norms and provided with CE marks and dedicated conformity certificate.

##### 3.1.1 Frame

All units are made from hot-galvanised thick sheet metal, to ensure the best resistance against the corrosions. The cabinet frame is made by removable panels to allow an easy inspection and internal maintenance. The condensing drip tray is supply as standrad in all models and it is made in plastic material.

##### 3.1.2 Refrigerant Circuit

The refrigerant circuit is made by using international primary brands components and according to ISO 97/23 concerning welding procedures. The refrigerant gas used in these units is R134a. The refrigerant circuit includes: filter drier, capillary expansion device, Schrader valves for maintenance and control, pressure safety device (according to PED regulation).

##### 3.1.3 Compressor

The compressor is reciprocating type, equipped with crankcase heater and thermal overload protection by a klixon embedded in the motor winding. It's mounted on rubber vibration dampers and, by request, it can be supplied with some jackets to reduce the noise (accessory).

##### 3.1.4 Condensers and Evaporators

The condensers and evaporators are made of copper pipes and aluminium fins. The diameter of the copper pipes is 3/8" and the thickness of the aluminium fins is 0,1 mm. The tubes are mechanically expanded into the aluminium fins to improve the heat exchange factor. The geometry of these condensers guarantees a low air side pressure drop and then the use of low rotation (and low noise emission) fans. All the units have a stainless steel drip tray. All WZ units configuration, in addition to these exchanger, use a third brazed plate heat exchanger made of stainless steel AISI 316 as condenser in cooling mode.

##### 3.1.5 Pre and post cold water coils

The pre and post cold water coils are made of copper pipes and aluminium fins. The diameter of the copper pipes is 3/8" and the thickness of the aluminium fins is 0,1 mm. The tubes are mechanically expanded into the aluminium fins to improve the heat exchange factor. The pre-cooling coil is used to increase the dehumidification capacity of the unit, while the post-cooling coil is used to keep the outlet air temperature at the same inlet value. In WZ version the pre-treatment coil only is present.

##### 3.1.6 Water condenser (only for WZ version)

Type-brazed plate, made of stainless steel AISI 316; The water condenser is used in the summer season as cooling integration.

##### 3.1.7 Supply fan

The supply fan is centrifugal type, double inlet with forwards blades, dynamically and statically balanced and directly connected to a 3 speed fan motor. Installed into the unit by interposed ant-vibration kit.

##### 3.1.8 Air Filter

Suministrados de serie con la unidad y fabricados en nylon, son extraibles para facilitar su limpieza, clase ISO COARSE 30% según UNI EN ISO 16890:2017

##### 3.1.9 Microprocessor

All units are equipped with a microprocessor for controlling the timing of the compressor, defrosting cycles and alarms. A special card with light signals indicates the presence of the supply voltage, the activation of defrosting cycle or the presence of an alarm.

##### 3.1.10 Electric box

The electric switch board is made according to electromagnetic compatibility norms CEE 73/23 and 89/336. The accessibility to the board

is possible after removing the front panel of the unit. Ready for the connection to the power and to the consensus control, The terminal board is also supplied with voltage free contacts for remote ON-OFF. The terminal block is also arranged with two (2) free contacts to allow operation in ventilation mode only (the 1st) in cooling mode operation (version WZ) the 2nd. Closing the first contact, it will be enabled for operation in fan only while the dehumidification function will be disabled.

### 3.1.11 Control and protection devices

All units are supplied with the following control and protection devices:

Water temperature sensor, that signals to the microprocessor the eventual overcome of the hot water temperature set point in the pre and post water coils during winter operation. In this condition the compressor is disconnected while the fan always run and, when the water temperature returns within the operation limits, restarts the compressor. The water sensor stops the compressor when the water temperature is above 35°C. The eventual use of the dehumidifier as heating device during winter season requires an additional remote thermostat with seasonal change over (not supplied).

### 3.1.12 Test

All the units are fully assembled and wired at the factory, carefully evacuated and dried after leak tests under pressure and then charged with ecologic refrigerant. They are all fully operational tested before shipment. They all conform to European Directives and are individually marked with the CE label and provided with Conformity Declaration.

## 3.2 Versions

### 3.2.1 WZ

Units supplied with double condenser (the first is an air condenser, the second is a water one) and of a logic which allows the dehumidification with neutrum air or with cooled air.

## 3.3 Accessories

### 3.3.1 Remote mechanical hygrostat (HYGR.20) (for standard versions only)

To be installed on the wall, it is supplied with a regulation knob and working range from 30% to 100% with precision of 3%.

### 3.3.2 Remote mechanical hygrostat (HYGR.30) (for WZversion only)

To be installed on the wall, it is supplied with a regulation knob and working range from 30% to 100%.  
Temperature working range from 10°C to 35 °C with precision of 3%.

### 3.3.3 Casing (CTFH.25)

In galvanized sheet allows the recess of the unit inside niche. The casing is provided with appropriate tabs for a secure fastening to the wall and arranged adequate openings for wiring and plumbing. The casing is provided with a neck part and assembly kit.

### 3.3.4 Supply and Return Grilles (GRFH)

In white lacquered wood, prepared for the inlet and outlet air temperature. The grille is installed on the dehumidifier deck using special fixing bolts supplied along with grille. The grille is provided with dedicated neck.

### 3.4 Unit components

#### Unit components standard version

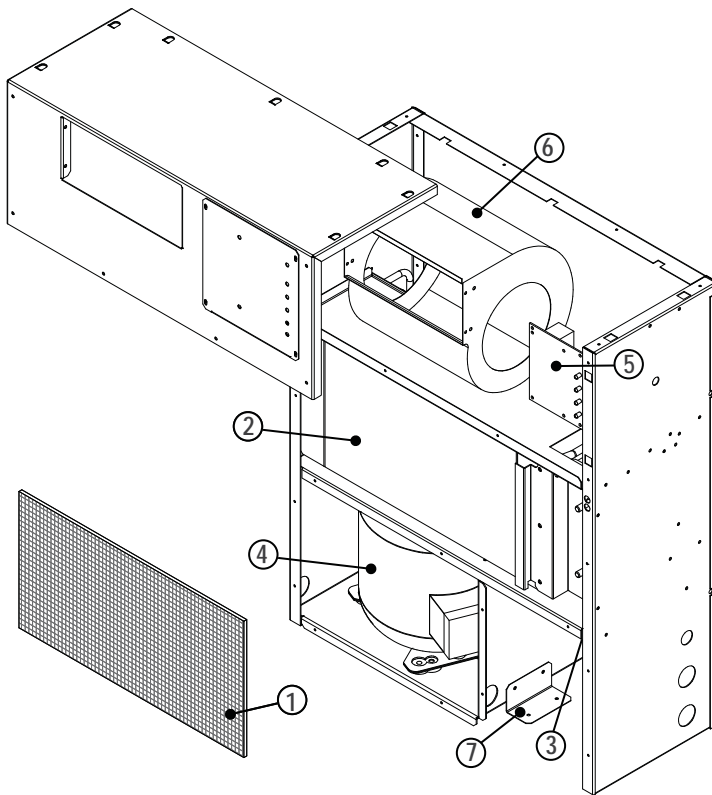

#### Unit components WZ version

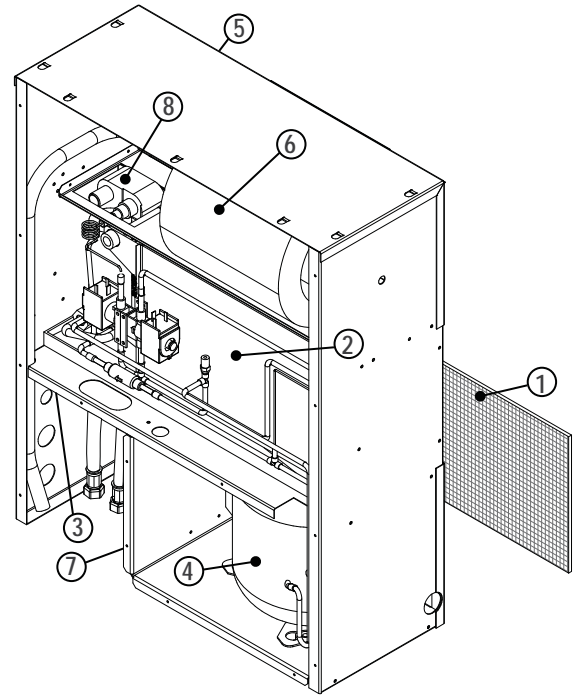

1	Air filter	5	Electronic card
2	Pre-cooling coil	6	Fan
3	Condensing drain	7	Bracket
4	Compressor	8	Condenser water

### 3.5 Refrigerant circuit layout

#### 3.5.1 Refrigerant circuit standard version

The functioning of the dehumidifier model FH is as follows: the fan takes the air from the ambient (7) and it's made go through the filter (1) and the pre-cooling water coil (2) where it's cooled and brought to a condition closed to saturation. Now it passes through the evaporating coil (3) where it's further cooled and dehumidified. The air passes now through the condensing coil (5) where it's post heated (with a constant humidity) and in the postcooling coil (6) where it's reported to the required conditions.



All the dehumidifiers model FH can work without the help of the pre and post cooling coils. This function is very useful in case there is the request of dehumidification in middle-season or when the chiller is off. Obviously, if the unit works without the help of the cold water, the air in outlet will be hotter than the air in inlet.

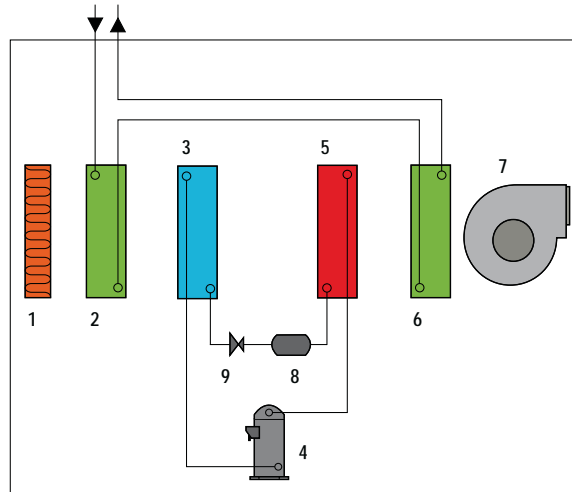

### 3.5.2 Refrigerant circuit layout WZ version

The operation of the dehumidifier model GH is as follows: the fan takes the air from the ambient (7) and it's made go through the filter (1) and the pre-cooling water coil (2) where it's cooled and brought to a condition closed to saturation. Now it passes through the evaporating coil (3) where it's further cooled and dehumidified. At this point there are two possible modalities:

- Modality with neutral air: The air passes now through the condensing coil (5) which allows to condensate the 50% of the total gas, (the unit condensate the 50% on air with the heat exchanger (5) and the 50% in water with the heat exchanger (10)) then there is the post-heating so that to avoid to send air in the ambient in neutral thermic conditions.
- Modality with cooled air: The unit condensates the 100% in water through the heat –exchanger (10). The air, then, go through the condenser (5) (disabled) where does not change its characteristics (temperature and humidity).
- Dehumidification with Air Heated mode: The unit in this case performs 100% of the condensation in the air with the heat exchanger (5) then the air at the evaporator outlet (3) passes through the condenser (5) that heats the air at constant humidity and then, the air that will be injected into the room has the same moisture that has output from the heat exchanger (3) but at a higher temperature.

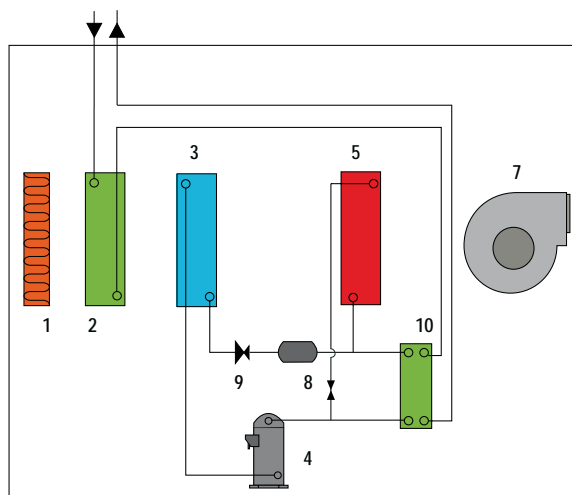

WZ versions can work with air dehumidification mode with cold air only if feed by the water plant (normally around 15 ÷ 18°C). In the absence of cold water, the units must be switched manually in winter mode, to operate in dehumidification + heating.

### 3.6 Technical data

Model FH		25
Moisture removed <sup>(1)</sup>	l/24h	20,1
Cooling capacity <sup>(1)</sup>	W	--
Total power input <sup>(1)</sup>	W	360
Max power input	W	440
Max input current	A	2,7
Peak current	A	18,1
Air flow	m <sup>3</sup> /h	250
Refrigerant		R134a
Global warming potential (GWP)		1430
Refrigerant charge	kg	0,2
Equivalent CO <sub>2</sub> charge	t	0,36
Water flow	l/h	150
Pressure drop	kPa	8
Sound power <sup>(2)</sup>	dB(A)	43
Sound pressure <sup>(3)</sup>	dB(A)	30
Power supply	V/Ph/Hz	230/1/50

Performances refer to the following conditions:

(1) Room Temperature 26 °C relative humidity 65%, with cold water coil water inlet temperature 15/20°C.

(2) Sound power level measured in accordance to ISO EN 3744.

(3) Sound pressure level measured at 1 mt from the unit according to ISO EN 3744.

### 3.7 Hydraulic circuit pressure drops

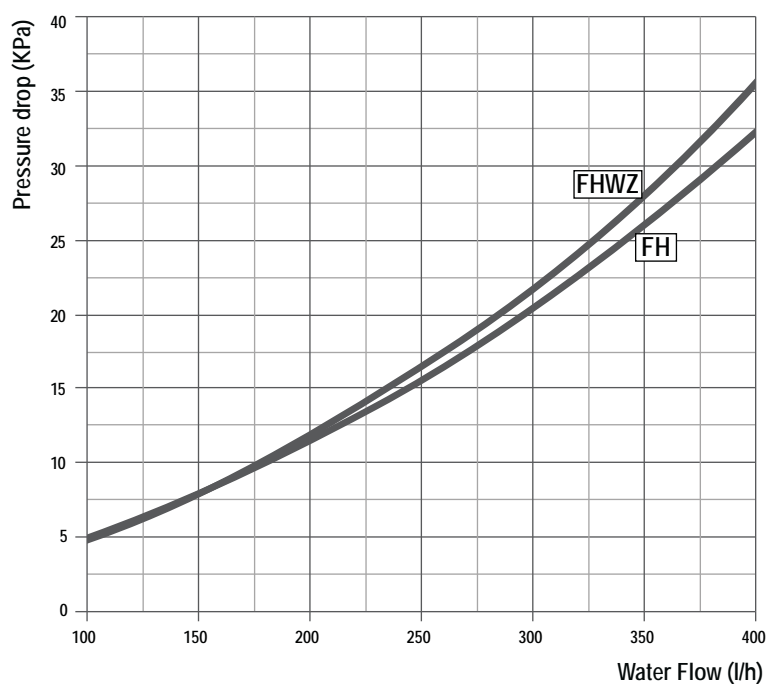



### 3.8 Operation limits

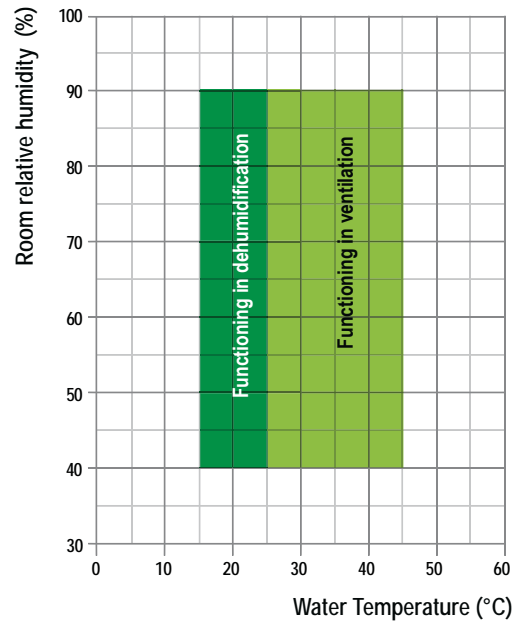
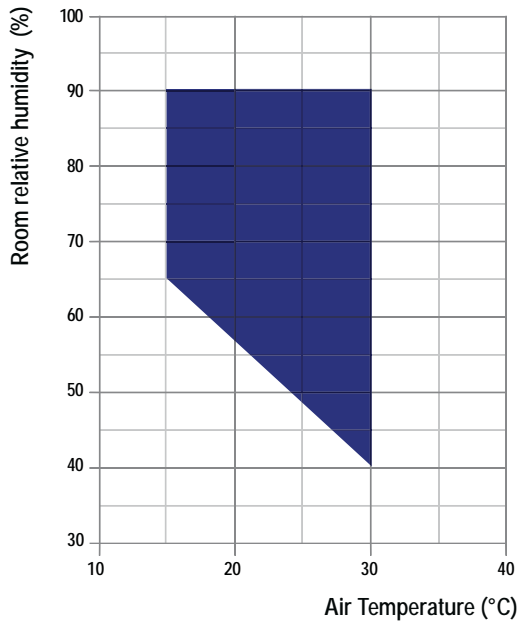

The units **MUST** be used within the operation limit indicated in the diagrams. The warranty will be invalidated if the units are used in ambient conditions outside the limits reported. If there is the necessity to operate in different conditions, please contact our technical office.



The units are designed and manufactured to work with ambient temperatures from 15 ° C to 30 ° C and relative humidity from 40% to 90%. The temperature of the supply water can vary from 15 ° C to 45 ° C. When the water temperature exceeds 25 ° C the unit will work only in ventilation mode.



The units are designed to operate within false ceiling and/or heated technical room. The units are **NOT** suitable for outdoor installations and / or technical room w/o heat (attics, rooms communicating with the outside) as it may form condensation on the walls and inside the unit cabinet causing damages.

### 3.9 Sound Data

SOUND DATA										
Mod.	Octave band (Hz)								Lw (A)	Lp (A)
	63	125	250	500	1K	2K	4K	8K	dB(A)	dB(A)
	dB(A)	dB(A)	dB(A)	dB(A)	dB(A)	dB(A)	dB(A)	dB(A)		
25 - 25WZ	56,1	47,3	41,2	39,7	38,6	33,2	29,8	20,7	43,0	30,0

Lw: Sound power level according to UNI EN ISO 3746:1997.

Lp: Sound pressure level measured at 1 mt from the unit in free field conditions direction factor Q=2 according to ISO 9614, minimum fan speed.

### 3.10 Safety devices

#### 3.10.1 High pressure switch

The high pressure switch stops the unit when the condensing pressure is higher than the set value. The restart is manual (you need to press the button on the pressure switch) and it can be carried out only when the pressure is under the value indicated by the differential set.

#### 3.10.2 Defrost thermostat

It's a device which signals to the electronic control, the necessity to make the defrost cycle. Once the defrost cycle is activated, the defrost thermostat determines also its conclusion.

#### 3.10.3 Safety thermostat

It's a device which signals to the electronic control that the limits have been exceeded (pre-post coil inlet water temperature). In this situation the compressor is disabled while the fan keeps on working. When the standard conditions are reset, the compressor starts its working again. This function is active only in winter.

#### 3.10.4 Defrost

The frost on the coil, obstructs the air flow, reduces the available exchange area and consequently the unit performances and can seriously damage the system. All the units are supplied, standard, with a control which defrost automatically the heat exchanger if necessary. This control provides a temperature probe (defrost thermostat) on the unit evaporator. When the defrost cycle is required, the microprocessor control (according to set parameters), switches the compressor off, while the fan remains in operation. At the end of the defrost cycle, it is waited for the dripping time to allow the complete cleaning of the coil, this process is carried out in cyclical mode.

### 3.11 Electric data

Electric data					
Power supply	V~/Hz	230/1/50	Control circuit	V~/Hz	24/1/ 50
Auxiliary circuit	V~/Hz	230/1/50	Fans power supply	V~/Hz	230/1/50

## 4. INSTALLATION

### 4.1 General safety guidelines and use of symbols



Before undertaking any task the operator must be fully trained in the operation of the machines to be used and their controls. They must also have read and be fully conversant with all operating instructions.



All maintenance must be performed by TRAINED personnel and be in accordance with all national and local regulations.



The installation and maintenance of the unit must comply with the local regulations in force at the time of the installation.



Avoid contact and do not insert any objects into moving parts.

## 4.2. Health and safety Considerations



The workplace must be kept clean, tidy and free from objects that may prevent free movement. Appropriate lighting of the work place shall be provided to allow the operator to perform the required operations safely. Poor or too strong lighting can cause risks.



Ensure that work places are always adequately ventilated and that respirators are working, in good condition and comply fully with the requirements of the current regulations.

## 4.3 Personal protective equipment



When operating and maintaining the unit, use the following personal protective equipment listed below, required by law.



Protective footwear.



Eye protection.



Protective gloves.



Respiratory protection.



Hearing protection.

## 4.4 Inspection

When installing or servicing the unit, it is necessary to strictly follow the rules reported on this manual, to conform to all the specifications of the labels on the unit, and to take any possible precautions of the case. Not observing the rules reported on this manual can create dangerous situations. After receiving the unit, immediately check its integrity. The unit left the factory in perfect conditions; any eventual damage must be questioned to the carrier and recorded on the Delivery Note before it is signed. The company must be informed, within 8 days, of the extent of the damage. The Customer should prepare a written statement of any severe damage.

### Before accepting the unit check:

- The unit did not suffer any damage during transport;
- The delivered goods are conforming to what shown in the delivery note.

### In Case of Damage

- List the damage on the delivery note
- Inform the Company of the extent of the damage within 8 days of receipt of the goods. After this time any claim will not be considered.
- A full written report is required for cases of severe damage.

## 4.5 Storage

Units should be stored under cover and ideally, should remain in their packaging. The tools that are supplied for opening the electrical box should be formally transferred to the person responsible for the plant.

## 4.6 Unpacking



Packaging could be dangerous for the operators.

It is advisable to leave packaged units during handling and remove it before the installation. The packaging must be removed carefully to prevent any possible damage to the machine. The materials constituting the packaging may be different in nature (wood, cardboard, nylon, etc.).



The packaging materials should be separated and sent for disposal or possible recycling to specialist waste companies.

## 4.7 Lifting and handling

When unloading the unit, it is strongly recommended that sudden movements are avoided in order to protect the refrigerant circuit, copper tubes or any other unit component. Units can be lifted by using a forklift or, alternatively, using belts. Take care that the method of lifting does not damage the side panels or the cover. It is important to keep the unit horizontal at all time to avoid damage to the internal components.

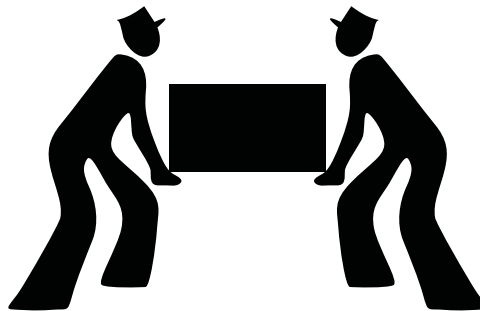

## 4.8 Location and minimum technical clearances



The unit has to be installed such that maintenance and repair is possible. The warranty does not cover costs for the provision of lifting apparatus, platforms or other lifting systems required to perform repairs during warranty period.



The installation site should be chosen in accordance with EN 378-1 and 378-3 standards. When choosing the installation site, all risks caused by accidental refrigerant leakage should be taken into consideration.

In the below drawing, the typical ceiling installation is shown (typical for residential buildings, offices etc.) where the unit is hanging thanks to the help of 4 brackets supplied standard. The brackets must be connected to the vibration dampers which have to be chosen according to the kind of structure they will be fixed to. It's advisable to cover the inside of the false ceiling with high density bitume layer and to foresee one or more openings to have the possibility to clean the air filters, to control the refrigerant circuit and to check the electrical board.



The casing front profile must be flush with the finished plaster wall.



Once the casing is fixed to the wall, the machine can be finally fitted. The unit is fixed to the casing using the dedicated screws supplied.

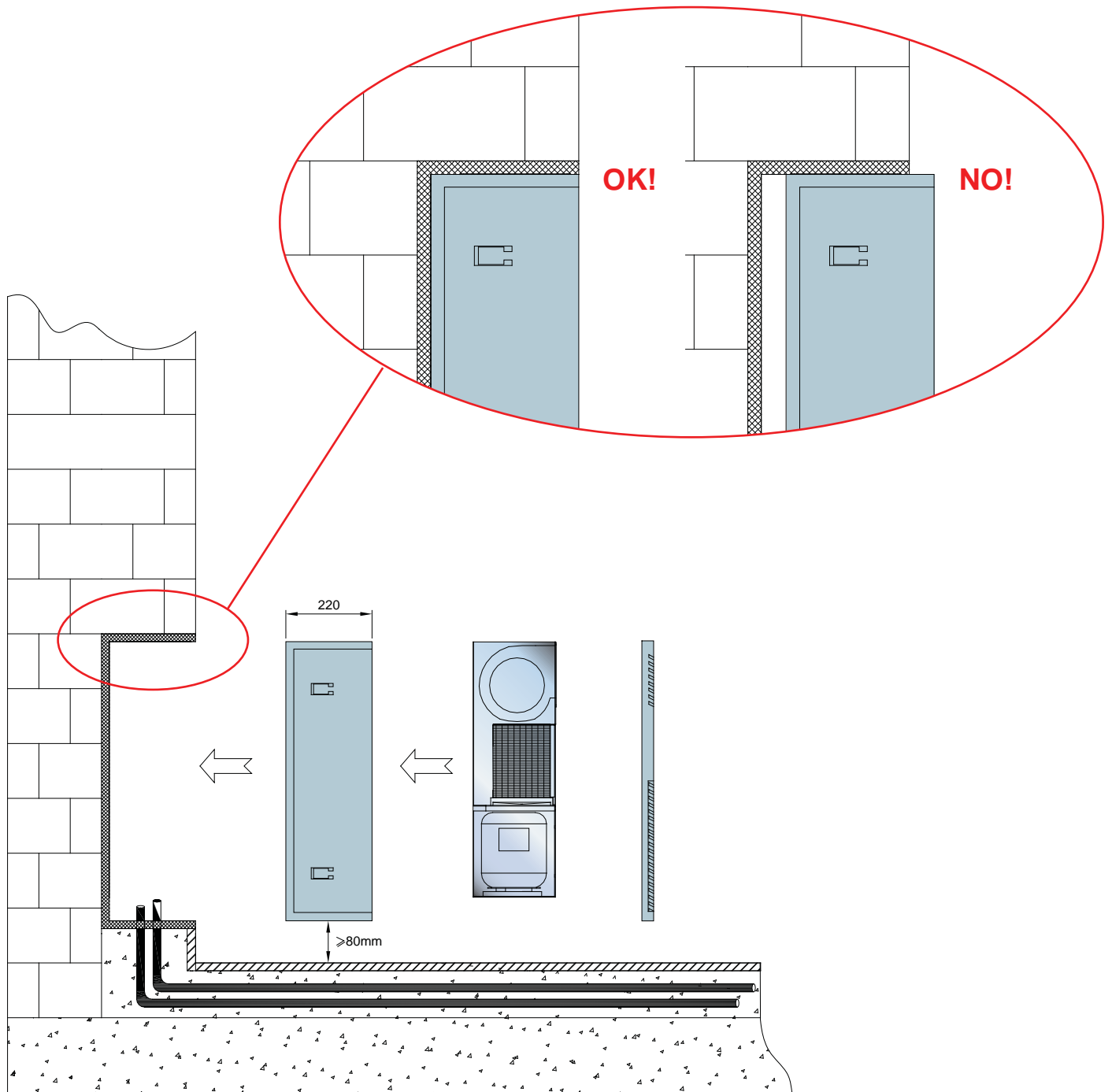

### 4.9 Assembly of the counter and its installation (CTFH.25)

The FH series dehumidifiers needs for its proper installation, a casing made of galvanized steel recessed in the wall. The housing will always be supplied separately and removed. For his installation, proceed to the assembly by following the instructions in this drawing, using the provided screws.

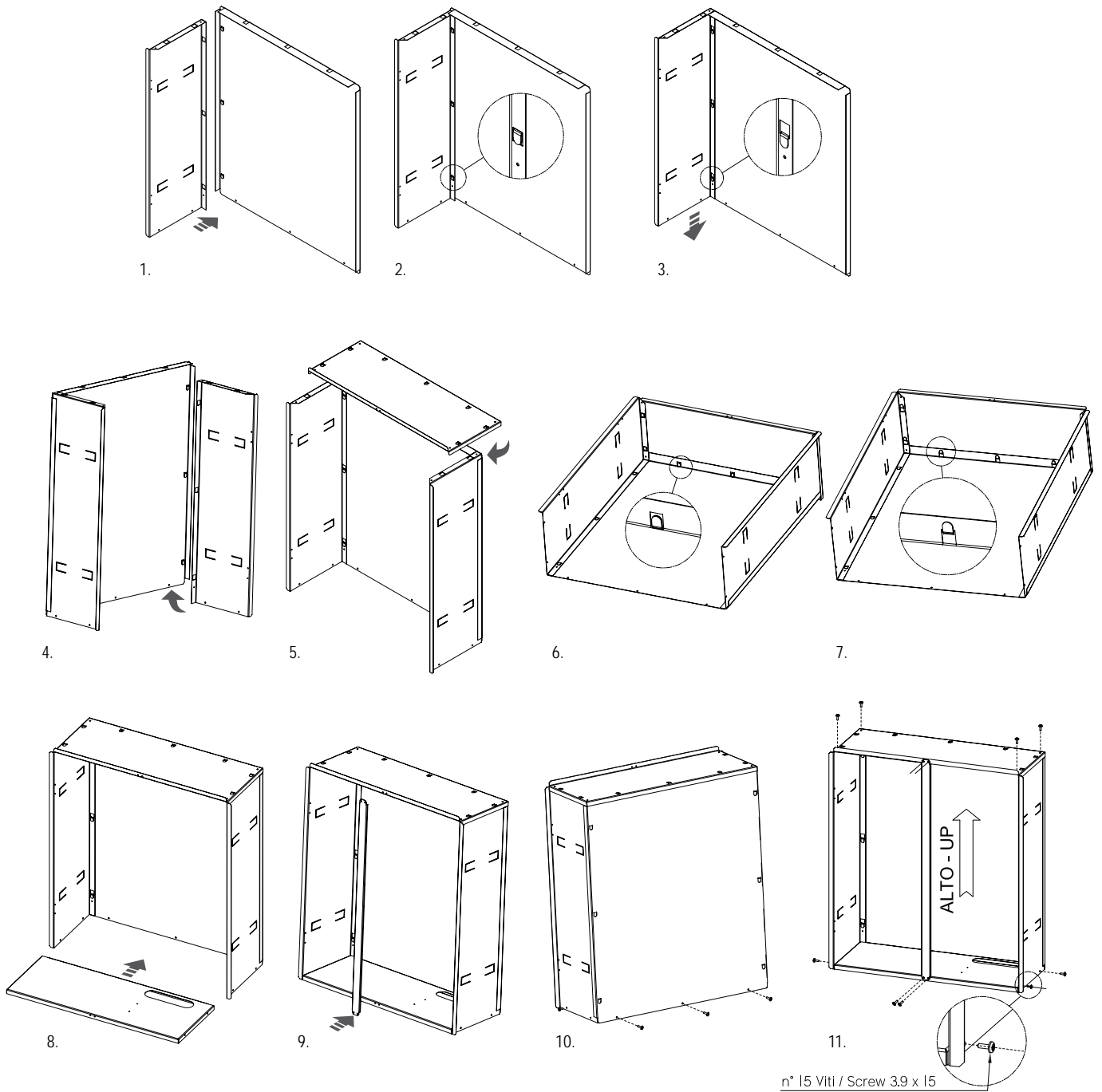

Before fitting the formwork into the dedicated niche , pre-slice kit must be open to facilitate its fastening (see photograph below).

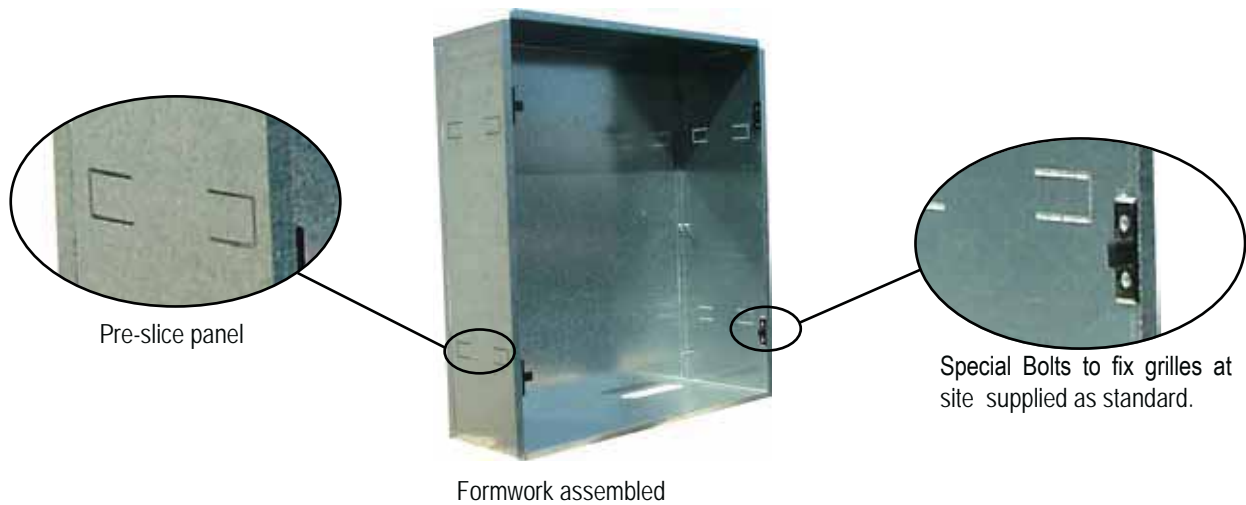

#### 4.10 Installation of dehumidifier into the formwork

The dehumidifier will be inserted in the formwork, possibly cutting the pre-slice placed in correspondence of the connections, in order to facilitate insertion. The final attachment to the formwork will be carried out on the right and left sides with screws, using the holes provided.

#### 4.11 Condensate draining connections

Condensate draining on FH-FHW units should be done with a rubber pipe passing fixed to a pipe fitting with an external diameter of 20 mm located on the lateral panel. On the condensate discharge pipe it must be installed a syphon with a minimum height equal to the suction pressure of the fan.

#### 4.12 Water coil hydraulic connection

The dehumidifier is connected to the cooled water plant to grant the inlet in ambient of air in neutral conditions. On the units FH-FHW the connection is done using the female gas attacks 1/2" always present on the unit.





For a correct functioning of the unit, it's advisable to bleed carefully the circuit using the vent valve present in the unit.



The inlet maximum water temperature allowed is 45°C.  
The inlet maximum water temperature allowed is 15°C.

#### 4.13 How to vent the unit

For a correct operation of the system it is mandatory to remove the air from the hydraulic circuit. To do that Hidros recommend to use the proper vent valve positioned in front of the unit (see picture).

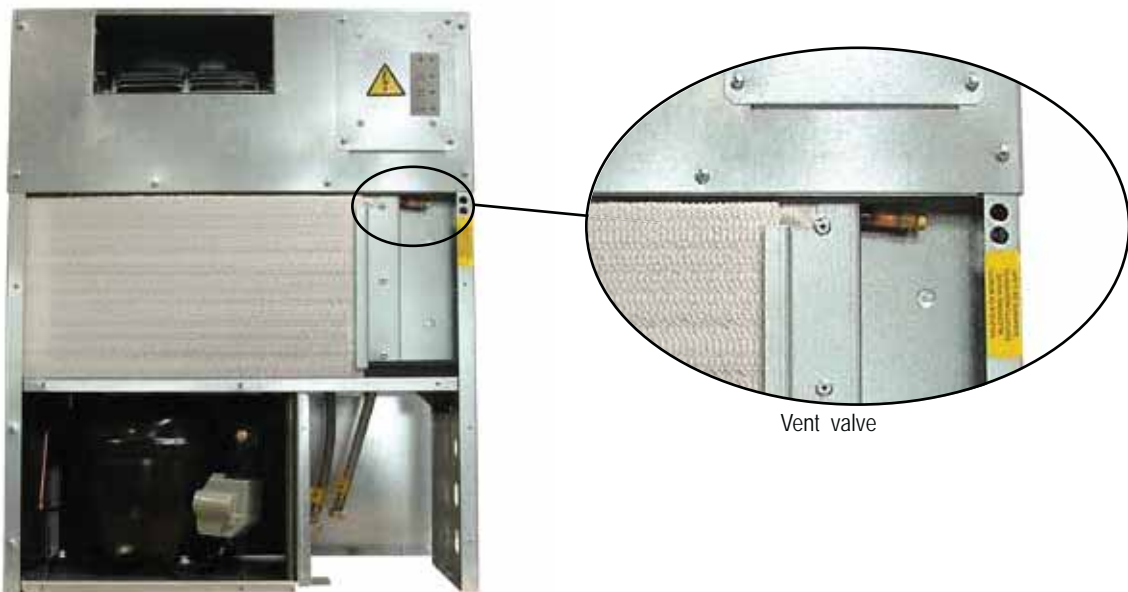

Vent valve

#### 4.14 Ductwork unit connection

All units are fitted with ductable centrifugal fans. In particular conditions, the air flow can be ducted. In this case the supply fan can be turned 90 ° (see drawing), thus allowing the channeling of unit.

In the case of channels a flanged connection with larger air eject hole must be used (refer to the dimensional drawing of unit).

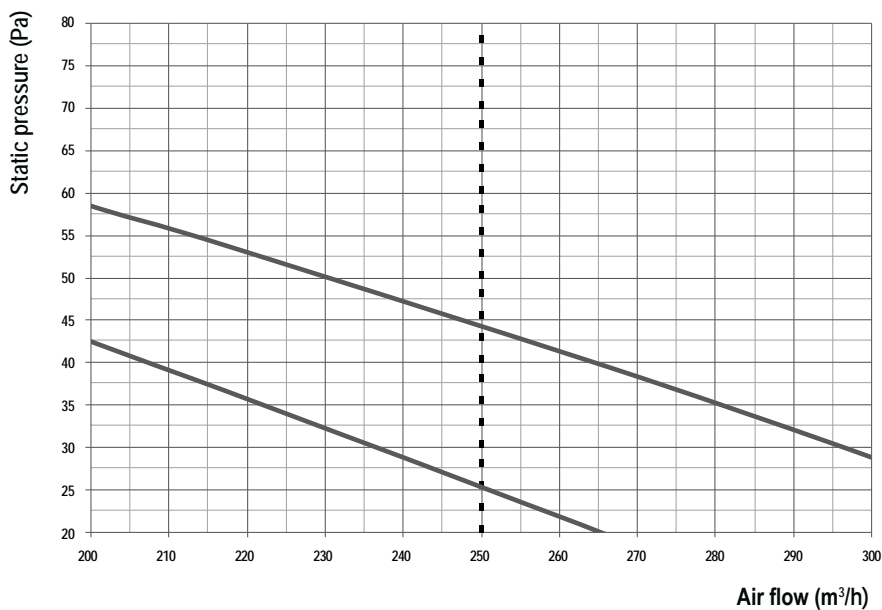





To allow the correct functioning of the dehumidifiers, it's important to grant a constant air flow to the unit. This flow must be close to the nominal value (see the drawing). The maximum tolerance allowed is 20%. .  
The installer will take care to verify, during the start-up, the air flow to the unit and modify, if necessary, the speed of the fans.



If the air speed through the evaporating coil exceed the 1,5÷2 m/s, the dehumidification capacity of the unit is strongly reduced and the required environmental conditions can be compromised.



Speed wired in factory.

#### 4.15 FH standard version: Remote mechanical hygrostat connection (HYGR.20)

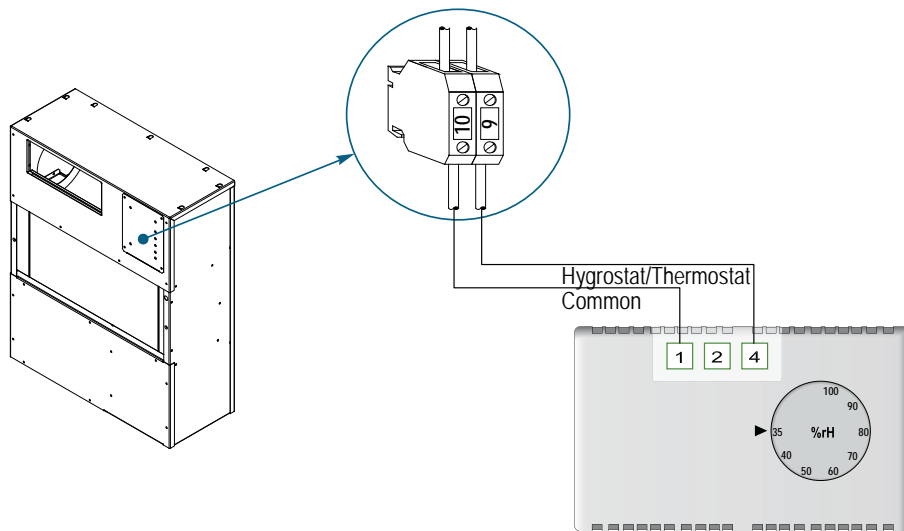

#### 4.16 FH version : Remote mechanical hygrostat connection (HYGR.30)

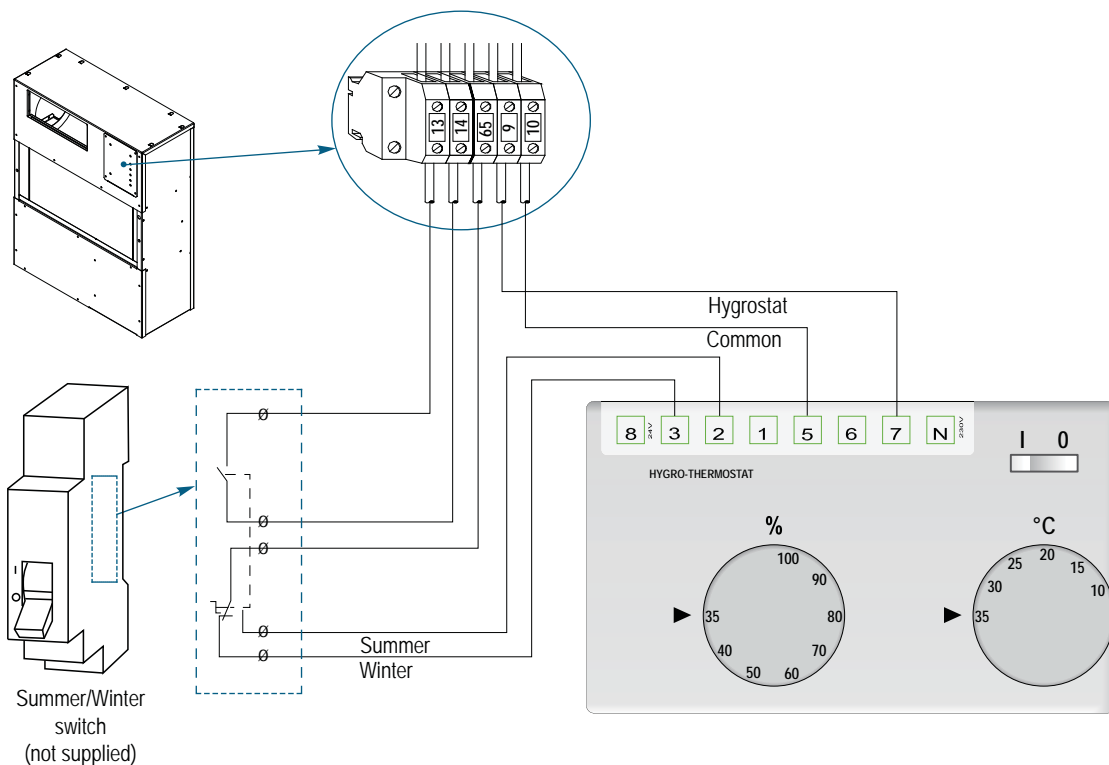

#### 4.17 Filter extraction

The filter extraction of a dehumidifier GH 50 is made unscrewing the two screws which fix it to the frame, as shown in the following images,

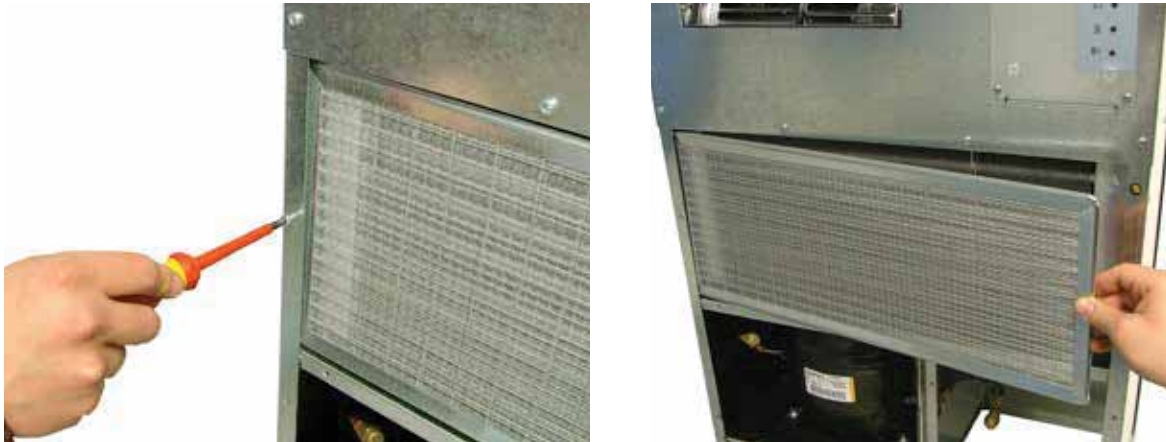

#### 4.18 Supply and return grilles installation

After the assembly and installation of the formwork, where it is secured within the unit FH-FHWZ , must be fitted to the formwork itself the supply and return grille. The supply and return grill, is a panel made of lacquered wood which has two grids, a small top (grille) and a larger (inlet grille). The grid serves to ensure a correct distribution of the air, is hooked to the formwork by means of hooks provided as standard. The grille is secured to the formwork by means of bolts supplied as standard.



Bolts for formwork fixing

## 4.19 Electric connections: preliminary safety information

The electric panel is located inside the unit at the top of the technical compartment where the various components of the refrigerant circuit are also to be found. To access the electrical board, remove the front panel of the unit:

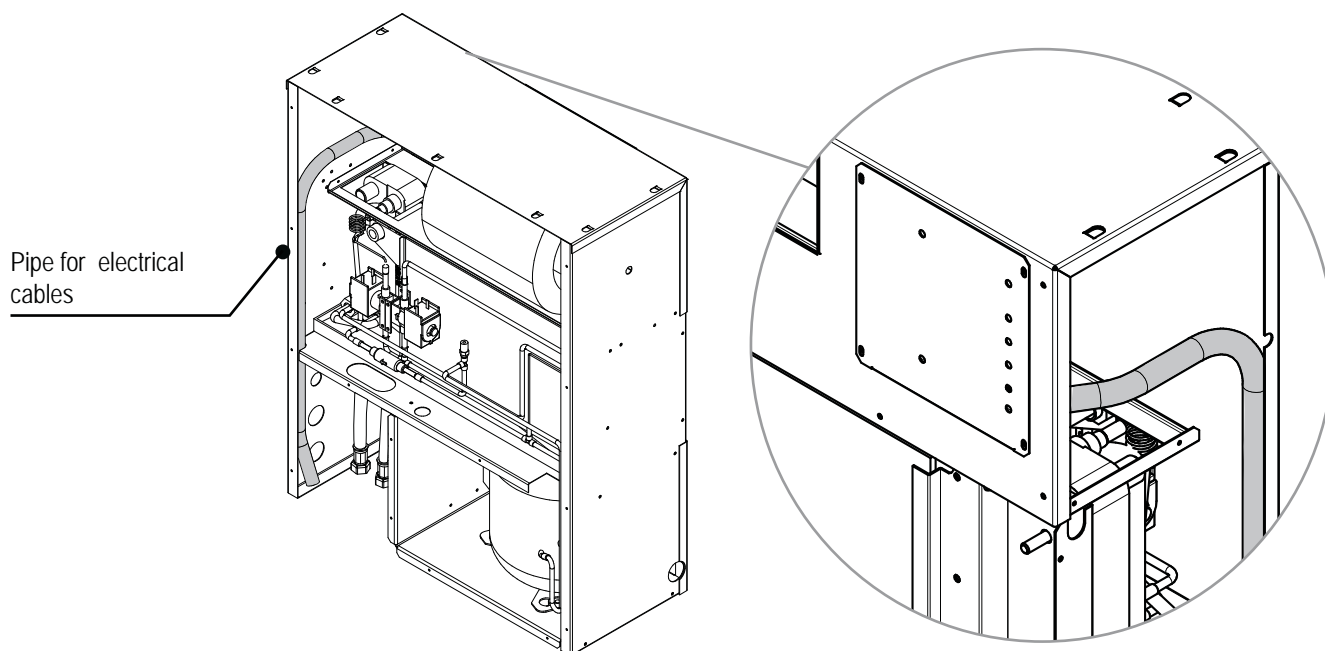

Power connections must be made in accordance to the wiring diagram enclosed with the unit and in accordance to the norms in force.



Make sure the power supply upstream of the unit is (blocked with a switch). Check that the main switch handle is padlocked and it is applied on the handle a visible sign of warning not to operate.



It must be verified that electric supply is corresponding to the unit electric nominal data (tension, phases, frequency) reported on the label in the front panel of the unit.



Power cable and line protection must be sized according to the specification reported on the form of the wiring diagram enclosed with the unit.



The cable section must be commensurate with the calibration of the system-side protection and must take into account all the factors that may influence (temperature, type of insulation, length, etc.).



Power supply must respect the reported tolerances and limits: If those tolerances should not be respected, the warranty will be invalidated.



Make all connections to ground provided by law and legislation.



Before any service operation on the unit, be sure that the electric supply is disconnected.

**FROST PROTECTION**

If opened, the main switch cuts the power off to any electric heater and antifreeze device supplied with the unit, including the compressor crankcase heaters. The main switch should only be disconnected for cleaning, maintenance or unit repair.

**4.20 Electrical data**

The electrical data reported below refer to the standard unit without accessories. In all other cases refer to the data reported in the attached electrical wiring diagrams.



The line voltage fluctuations can not be more than  $\pm 10\%$  of the nominal value, while the voltage unbalance between one phase and another can not exceed 1%, according to EN60204. If those tolerances should not be respected, please contact our Company.

Model	25	
Power supply	VI-/Hz	230/1/50
Control board	VI-/Hz	24V
Auxiliary circuit	VI-/Hz	230/1/50
Fans power supply	VI-/Hz	230/1/50
Line section	mm <sup>2</sup>	1,5
PE section	mm <sup>2</sup>	1,5



Electric data may change for updating without notice. It is therefore necessary to refer always to the wiring diagram present in the units.

**4.21 Electrical connections**

The power supply must correspond to the electric nominal data (tension, phases, frequency) reported on the label in the front panel of the unit. Power connections must be made in accordance to the wiring diagram enclosed with the unit and in accordance to the norms in force. Power cable and line protection must be sized according to the specification reported on the wiring diagram enclosed with the unit.



Electric supply must be in the limits shown: in the opposite case warranty will terminate immediately. Before every operation on the electric section, be sure that the electric supply is disconnected.



The unit can be correctly activated only if the connections of the dehumidification and ventilation remote contacts (example: hygrostat, microprocessor control, etc) will be made. In this respect, please, follow very strictly what is reported in the wiring diagram.



**FAN SPEED:** The unit is provided of a 3-speed fan which is regularly connected to the medium speed. In case it's necessary to change the speed, it's sufficient to change the connection in the block located in the electrical board.



**FORCING THE UNIT IN ONLY VENTILATION:** in the terminal board, it's available a contact which allow the unit to work in only ventilation. Closing this contact, only the fan works. The dehumidification mode is not in function.



WZ version units must be connected to an ambient Hygrostat/Thermostat. Failure to use one of the two components prevents proper operation in different modes.

#### 4.21.1 Remote wiring connections (compulsory)



The numbers of terminals block may change without notice. For links is therefore necessary to ALWAYS make the wiring diagram supplied along with the unit.

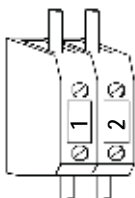

##### REMOTE ON / OFF (Only WZ versions)

To switch the unit on or off from remote control.  
Use voltage free contacts.  
The units are supplied as standard from the factory with bridged terminals.  
Contact closed, unit ON,  
Contact open, unit OFF.

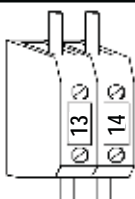

##### REMOTE SUMMER / WINTER CHANGE OVER (Only WZ versions)

It is used for remote switching summer / winter  
The units are supplied as standard from the factory with no-bridge terminals.  
Use voltage free contacts .  
Contact closed, unit in WINTER mode,  
Contact open, unit SUMMER mode.

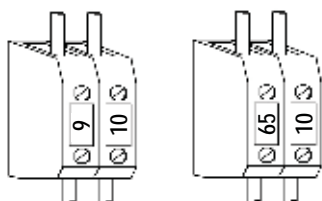

##### AMBIENT HYGROSTAT (UA) e AMBIENT THERMOSTAT (TA)

Ambient Hygrostat (standard version) connected to terminal 9, ambient thermostat (WZ version) connected to the terminal 65.

##### Summer mode functionality

Terminal 9 closed, 65 open: Unit in dehumidification mode with neutral air.  
Terminal 65 closed : unit in dehumidification mode with cooling.  
Terminal 9 open, 65 open: unit in stand-by

##### Winter mode functionality

Terminal 9 closed: unit in dehumidification mode with heating  
Terminal 65 closed: unit in ventilation mode (see below)

The units are supplied as standard from the factory with no-bridge terminals.

#### 4.21.2 Remote wiring connections (optional)

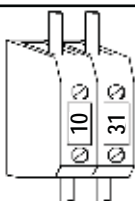

##### FAN FORCED

It is used to force the unit in ventilation mode only.  
Terminal are free voltage.  
Terminal closed fan forced ON  
Terminal open fan forced OFF  
The units are supplied as standard from the factory with no-bridge terminals.

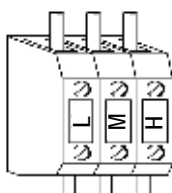

##### FAN SPEED

The unit is equipped with a three-speed fan, factory wired at medium speed.  
To vary the rotation fan speed , move:  
Cable n. 18 connected at L: LOW SPEED  
Cable n. 18 connected at M: MEDIUM SPEED  
Cable n. 18 connected at H: HIGH SPEED

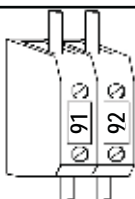

##### GENERAL ALARM

It is used to remote unit general alarm.  
Terminal closed: Unit alarm IN  
Terminal open: unit WORKING

## 5. UNIT START UP

### 5.1 Preliminary checks

Before starting the unit the checks detailed in this manual of the electric supply and connections, the hydraulic system and the refrigerant circuit, should be performed.



Start-up operations must be performed in accordance with the instructions detailed in the previous paragraphs.

#### 5.1.1 Before start-up





Damage can occur during shipment or installation. It is recommended that a detailed check is made, before the installation of the unit, for possible refrigerant leakages caused by breakage of capillaries, pressure switch connections, tampering of the refrigerant pipework, vibration during transport or general abuse suffered by the unit.

- Verify that the unit is installed in a workmanlike manner and in accordance with the guidelines in this manual.
- Check that all power cables are properly connected and all terminals are correctly fixed.
- The operating voltage the one shown on the unit labels.
- Check that the unit is connected to the system earth.
- Check that there is no refrigerant leakage.
- Check for oil stains, sign of a possible leak.
- Check that the refrigerant circuit shows the correct standing pressure on the pressure gauges (if present) otherwise use external ones.
- Check that the Shrader port caps are the correct type and are tightly closed.
- Check that all water connections are properly installed and all indications on unit labels are observed.
- The system must be flushed, filled and vented in order to eliminate any air.
- Check that the water temperatures are within the operation limits reported in the manual.
- Before start up check that all panels are replaced in the proper position and locked with fastening screws.



Do not modify internal wiring of the unit as this will immediately invalidate the warranty.

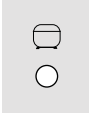

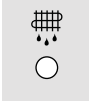
### 5.2 Control panel

Icon	Meaning
	<b>Electrical supply (green):</b> indicates that green switch has been turned in On position and the unit is electrically supplied.
	<b>Compressor led (green):</b> indicates compressor status with the following meanings: led ON: compressor running; led blinking: compressor time delay to start;
	<b>Alarm led (red):</b> indicates the unit alarm status Red led ON or blinking: see paragraph 6.4
	<b>Defrost led (yellow):</b> indicates that the units is executing the defrost cycle; led fastly blinking: execution of drop cycle at the defrost end;

## 6. USE

### 6.1 Unit switch on and first start up

#### 6.1.1 Standard version

Place the main line switch (not supplied) to ON. In the case of hygrostat call the fan is activated, and the request to start the compressor (delayed by 3 minutes) is activated too. During this period the compressor LED  stops flashing). The units work in cyclic mode by activating the compressor for 40 minutes of running and 12 minutes in defrost mode (during the defrost LED  flashes).

#### 6.1.2 WZ version

The operation mode is identical to the standard version and, in addition to the humidity control (hygrostat), they also control the temperature by means of a ambient thermostat. The hygrostat activate the dehumidification mode with neutral air, while the thermostat activate the dehumidification mode with air-cooled.







### 6.2 Stop

To switch off the unit place the main line in OFF.

### 6.3 Stand-by

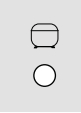
When the unit is switched off from the hygrostat a/o thermostat the unit will be than in standby mode. In this mode, the only visible signs are the green power LED. .

### 6.4 Displaying during an alarm

Icon	Meaning	Cause	Rimedio
	High pressure alarm. Steady red LED. Reset is automatic if the alarm occurs no more than three times an hour. More than three times an hour the alarm becomes manual reset. To reset it simply remove and restore power.	Low air flow. Clogged filter. Low water level. High Water temperature.	Restore the correct air flow, check the ducts pressure drop. Clean the filter. Restore the correct water temperature.
	Low pressure alarm. Flashing red light. This alarm is delayed by 60 seconds. Reset is automatic if the alarm occurs no more than three times an hour. More than three times an hour the alarm becomes manual reset. To rest it simply remove and restore power..	High water flow  Low water temperature	Restore the correct water flow  Restore the correct water temeparture
 	Thermal alarm compressor. Red and green LED flashing simultaneously. This alarm is always a manual reset.	Possible refrigerat circuit damage.	Please contact servive center.
 	Alarm defrost termination for exceeding the time limit. Led red and yellow flashing simultaneously.	Low ambient temperature  Gas discharge unit	Restore the correct ambient temperature  Please contact servive center.
 	NTC sensor error alarm. LED alternately flashing red and yellow.	PTC probe sensor damage	Please contact servive center.

## 7. MAINTENANCE OF THE UNIT

### 7.1 General warnings



Starting from 01/01/2016 the new European Regulation 517\_2014, "Obligations concerning the containment, use, recovery and destruction of fluorinated greenhouse gases used in stationary refrigeration, air conditioning and heat pumps", became effective. This unit is subject to the following regulatory obligations, which have to be fulfilled by all owners, operators and technical staff:

- (a) Keeping the equipment records
- (b) Correct installation, maintenance and repair of equipment
- (c) Leakage control
- (d) Refrigerant recovery and disposal management
- (e) Presentation to the Ministry of the Environment of the annual declaration concerning the atmospheric emissions of fluorinated greenhouse gases.

Maintenance can:

- Keep the equipment operating efficiently
- Prevent failures
- Increase the equipment life



It is advisable to maintain a record book for the unit which details all operations performed on the unit as this will facilitate troubleshooting.



Maintenance must be performed in compliance with all requirements of the previous paragraphs.



Use personal protective equipment required by regulations as compressor casings and discharge pipes are at high temperatures. Coil fins are sharp and present a cutting hazard.



If the unit is not to be used during the winter period, the water contained in the pipes may freeze and cause serious damage. In this event, fully drain the water from the pipes, checking that all parts of the circuit are empty including any internal or external traps and siphons.



If it is necessary to replace a component of the machine, both for ordinary and extraordinary maintenance, this component must have the same or higher characteristics than those present. The same or higher performances or thicknesses are meant for the characteristics, which do not compromise the safety, the use, the handling, the storage, the pressures and the temperatures of use of the machine provided by the manufacturer.



The taps in the machine must always be in open position before starting. If it is necessary to disconnect the refrigeration circuit by closing the taps, it is necessary to take precautions to prevent the unit from starting up, even accidentally, and to indicate that the taps have been properly closed with special signs, both on the tap and in the electrical panel. In any case, the taps must remain closed as less as possible.



### 7.2 Drive access

Access to the unit once installed, should only be possible to authorized operators and technicians. The owner of the equipment is the company legal representative, entity or person owns the property where the machine is installed. They are fully responsible for all safety rules given in this manual and regulations.

### 7.3 Scheduled maintenance

The owner must make sure that the unit is periodically inspected, also on-site, adequately maintained, according to the type, size, age and use of the system, and to the indications contained in the Manual.

Servicing during the unit's operating lifetime and, in particular, scheduled leak detection, on-site inspections and check-ups of safety equipment, must be carried out as provided by local laws and regulations in force.



If leak detection instruments are installed on the system, they must be inspected at least once a year, to make sure that they work properly.

During its operating life, the unit shall be inspected and verified in accordance with applicable local laws and regulations. In particular, when there are no stricter specifications, the indications given in the following table (see EN 378-4, Annex D) must be followed, with reference to the situations described.

CASE	Visual Inspection	Pressure Test	Search for leaks
A	X	X	X
B	X	X	X
C	X		X
D	X		X

A	Inspection after an intervention with possible effects on the mechanical strength or after use change or in case the machine has not being working for more than two years. Replace all the components which are not suitable any more. Do not carry out checks at a higher pressure than the one indicated in the project.
B	Inspection after a repair, or significant adjustment of the system, or its components. The check may be limited to the interested parts, but if a leakage of refrigerant is detected, a leakage search must be carried out on the entire system.
C	Inspection after installation in a different position than the original one. Refer to point A when mechanical strength could have been affected by the change.
D	Leak search, following a well-founded suspicion of refrigerant leakage. It is recommended examined the system for leakage, either directly (use of leak detection systems) or indirectly (deduction of leakage based on analysis of operating parameters), focusing on the parts most prone to leakage (e.g. joints).



If a defect is detected that compromises the reliable operation of the unit, the unit cannot be re-started until it has been repaired.

### 7.4 Periodical checks



The start-up operations should be performed in compliance with all requirements of the previous paragraphs.



All of the operations described in this chapter **MUST BE PERFORMED BY TRAINED PERSONNEL ONLY**. Before commencing service work on the unit ensure that the electric supply is disconnected. The top case and discharge line of compressor are usually at high temperature. Care must be taken when working in their surroundings. Aluminium coil fins are very sharp and can cause serious wounds. Care must be taken when working in their surroundings. After servicing, replace the cover panels, fixing them with locking screws.

### 7.4.1 Electrical system and adjustment

Action to be performed	Frequency					
	Monthly	Every 2 months	Every 6 months	Every year	Every 5 years	As necessary
Check that the unit works properly and that there are no active warnings	X					
Visually inspect the unit	X					
Check noise and vibration level of the unit				X		
Check operation of safety features and of interlocks				X		
Check the unit's performance				X		
Check the current draws of the different parts (compressors, fans, pumps, etc.)				X		
Check the supply voltage of the unit			X			
Check tightness of cables in their clamps			X			
Check the integrity of the insulating coating of power cables				X		
Check the conditions and functioning of the counters				X		
Check functioning of the microprocessor and of the display			X			
Clean the electrical and electronic components of any dust				X		
Check functioning and calibration of probes and transducers				X		

### 7.4.2 Condensing coils and fans

Action to be performed	Frequency					
	Monthly	Every 2 months	Every 6 months	Every year	Every 5 years	As necessary
Visually inspect the coil	X					
Clean finned coils			X			
Check the water flow and/or any leaks (if HOWA is present)	X					
Clean the metal filter on the external water line <sup>(2)</sup> (if present)			X			
Check noise and vibration level of the fans				X		
Check the supply voltage of the fans			X			
Check the fans' electrical connections				X		
Check functioning and calibration of the fans' speed adjustment system (if present)				X		
Check air presence in the hydraulic circuit	X					
Check color of moisture indicator on liquid line				X		
Check for freon leaks <sup>(1)</sup>						X



<sup>(1)</sup> In order to carry out operations on the refrigerant, it is necessary to observe the European Regulation 517\_2014, "Obligations regarding the containment, use, recovery and destruction of fluorinated greenhouse gases used in stationary refrigeration, air conditioning and heat pump equipment".



<sup>(2)</sup> It can be carried out with a higher frequency (also weekly) depending on the  $\Delta t$ .

### 7.4.3 Compressors

Action to be performed	Frequency					
	Monthly	Every 2 months	Every 6 months	Every year	Every 5 years	As necessary
Visually inspect compressors				X		
Check noise and vibration level of the compressors				X		
Check the supply voltage of the compressors			X			
Check the compressors' electrical connections				X		
Check oil level in the compressors using the oil fill level indicator (if present)			X			
Check that the crankcase heaters are powered and working properly (if present)				X		
Check the conditions of the compressors' power cables and their tightness in the clamps			X			



Daily and monthly works may be carried out directly by the Owner of the system. All other works must be performed by authorised and trained personnel.



Any kind of cleaning whatsoever is forbidden before disconnecting the device from power supply by turning the master switch to the OFF position. It is forbidden to touch the device while barefooted or with wet or damp body parts.



Works on the cooling line must be carried out by qualified and trained technicians, as provided by local laws and regulations in force.



Before the start-up it is necessary to carry out all the operations described in the previous tables and make the necessary checks provided by the pre-start control module (valid for the Italian market) to be requested to the service.

### 7.5 Refrigerant circuit repair



If the refrigerant circuit is to be emptied, all the refrigerant must be recovered using the correct equipment.

For leak detection, the system should be charged with nitrogen using a gas bottle with a pressure reducing valve, until 15 bar pressure is reached. Any leakage is detected using a bubble leak finder. If bubbles appear discharge the nitrogen from the circuit before brazing using the proper alloys.



Never use oxygen instead of nitrogen: explosions may occur.

Site assembled refrigerant circuits must be assembled and maintained carefully, in order to prevent malfunctions.

Therefore:

- Avoid oil replenishment with products that are different from that specified and that are pre-loaded into the compressor.
- In the event of a gas leakage on machines using refrigerant R134A, R410A even if it is only a partial leak, do not top up. The entire charge must be recovered, the leak repaired and a new refrigerant charge weighed in to the circuit.
- When replacing any part of the refrigerant circuit, do not leave it exposed for more than 15 minutes.
- It is important when replacing a compressor that the task be completed within the time specified above after removing the rubber sealing caps.
- When replacing the compressor following a burn out, it is advisable to wash the cooling system with appropriate products including a filter for acid.
- When under vacuum do not switch on the compressor.

## 8. DECOMMISSIONING

### 8.1 Disconnect the unit



All decommissioning operations must be performed by authorized personnel in accordance with the national legislation in force in the country where the unit is located.

- Avoid spills or leaks into the environment.
- Before disconnecting the machine please recover:
  - the refrigerant gas;
  - Glycol mixture in the hydraulic circuit;
  - the compressor lubricating oil.

Before decommissioning the machine can be stored outdoors, providing that it has the electrical box, refrigerant circuit and hydraulic circuit intact and closed.

### 8.2 Disposal, recovery and recycling

The frame and components, if unusable, should be taken apart and sorted by type, especially copper and aluminum that are present in large quantities in the machine.

All materials must be recovered or disposed in accordance with national regulations.



The refrigerant circuit of the unit contains lubricant oil that binds the disposal mode of components .

### 8.3 RAEE Directive (only UE)



The crossed-out bin symbol on the label indicates that the product complies with regulations on waste electrical and electronic equipment.

The abandonment of the equipment in the environment or its illegal disposal is punishable by law.

This product is included in the application of Directive 2012/19/EU on the management of waste electrical and electronic equipment (WEEE).

The unit should not be treated with household waste as it is made of different materials that can be recycled at the appropriate facilities. Inform through the municipal authority about the location of the ecological platforms that can receive the product for disposal and its subsequent proper recycling.

The product is not potentially dangerous for human health and the environment, as it does not contain dangerous substances as per Directive 2011/65/EU (RoHS), but if abandoned in the environment it has a negative impact on the ecosystem.

Read the instructions carefully before using the unit for the first time. It is recommended not to use the product for any purpose other than that for which it was designed, as there is a risk of electric shock if used improperly.

## 9. DIAGNOSIS AND TROUBLESHOOTING

### 9.1 Fault finding

All units are checked and tested at the factory before shipment, however, during operation an anomaly or failure can occur.



BE SURE TO RESET AN ALARM ONLY AFTER YOU HAVE REMOVED THE CAUSE OF THE FAULT; REPEATED RESET MAY RESULT IN IRREVOCABLE DAMAGE TO THE UNIT.

Problema	Causa	Rimedio
The unit doesn't start	Power supply missing	Provide power supply
	Line switch open	Close the main line switch.
	Remote contact opened	Close the contact
	Electronic board defective	Replace defective board
Fan starts, compressor does not start	Compressor thermal protection enabled, compressor defective	Let the compressor cool down, and restart; in case, replace compressor defective
	Electronic board defective	Replace defective board
The unit is powered, the fan does not start	Electronic board defective	Replace defective board

### 10.DIMENSIONAL DRAWINGS

#### Dimensional drawing FH 25 - 25WZ

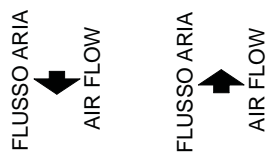
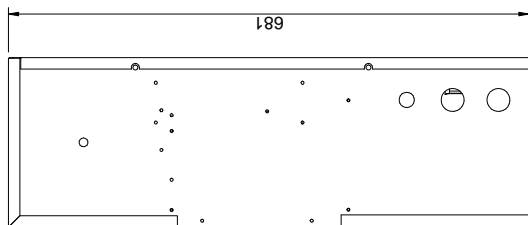
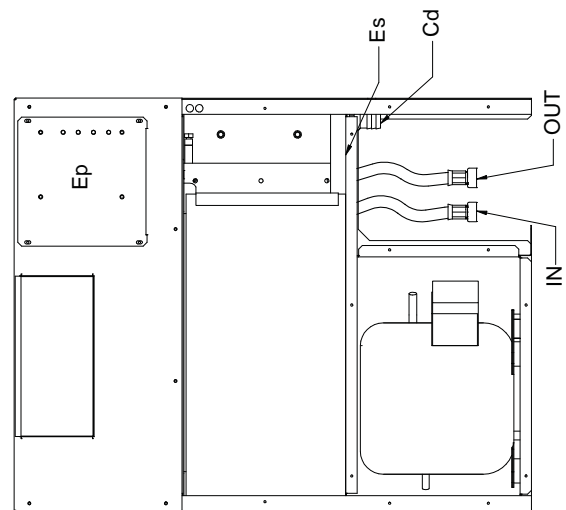
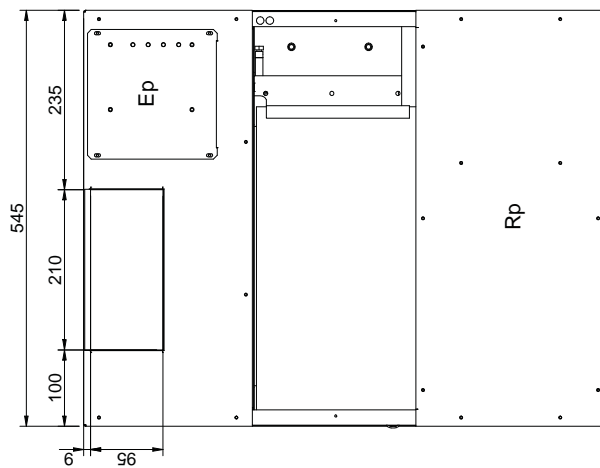
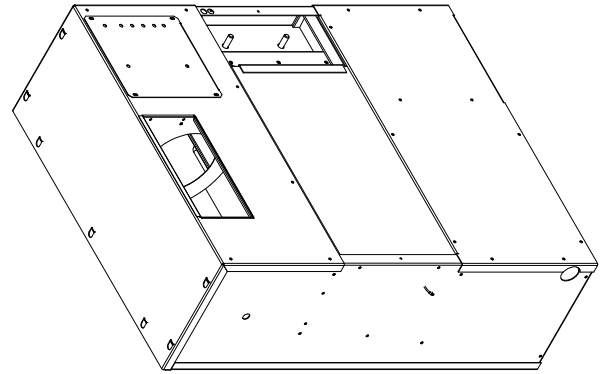
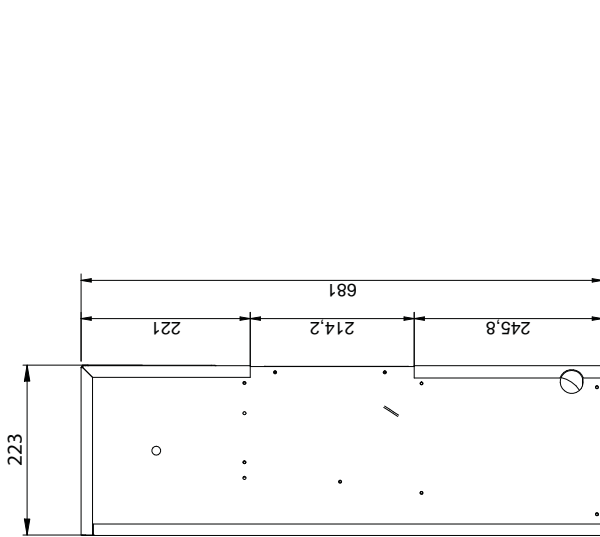

WEIGHT OF THE UNIT	
Modd.	WEIGHT (Kg)
FH 25	45
FHWZ 25	38

Rp	REMOVABLE PANEL
Ep	ELECTRICAL PANEL
Es	POWER SUPPLY DRAIN INLET
Cd	CONDENSATE DRAIN
OUT Ø1/2"GF	USER WATER OUTLET
IN Ø1/2"GF	USER WATER INLET

**Dimensional drawing formwork FH (CTFH.25)**

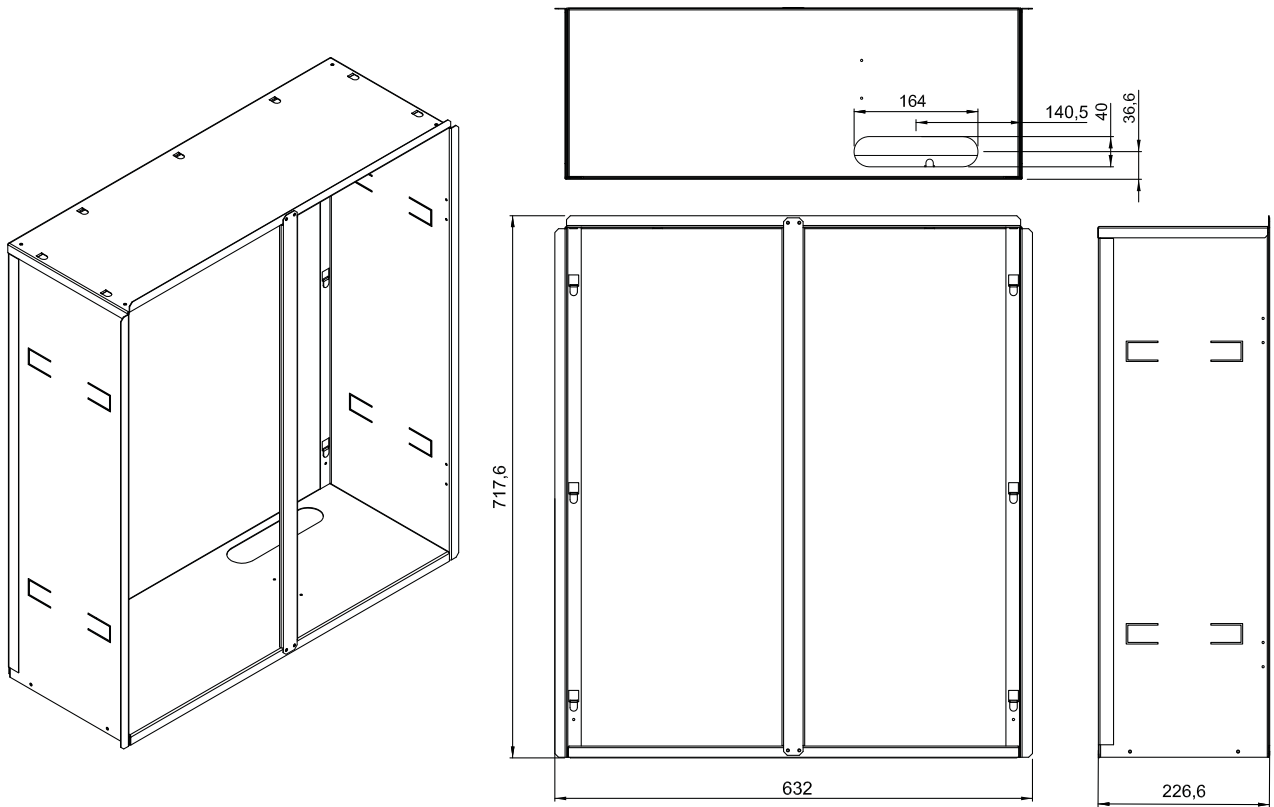

**Dimensional drawing supply and return grilles FH (GRFH)**

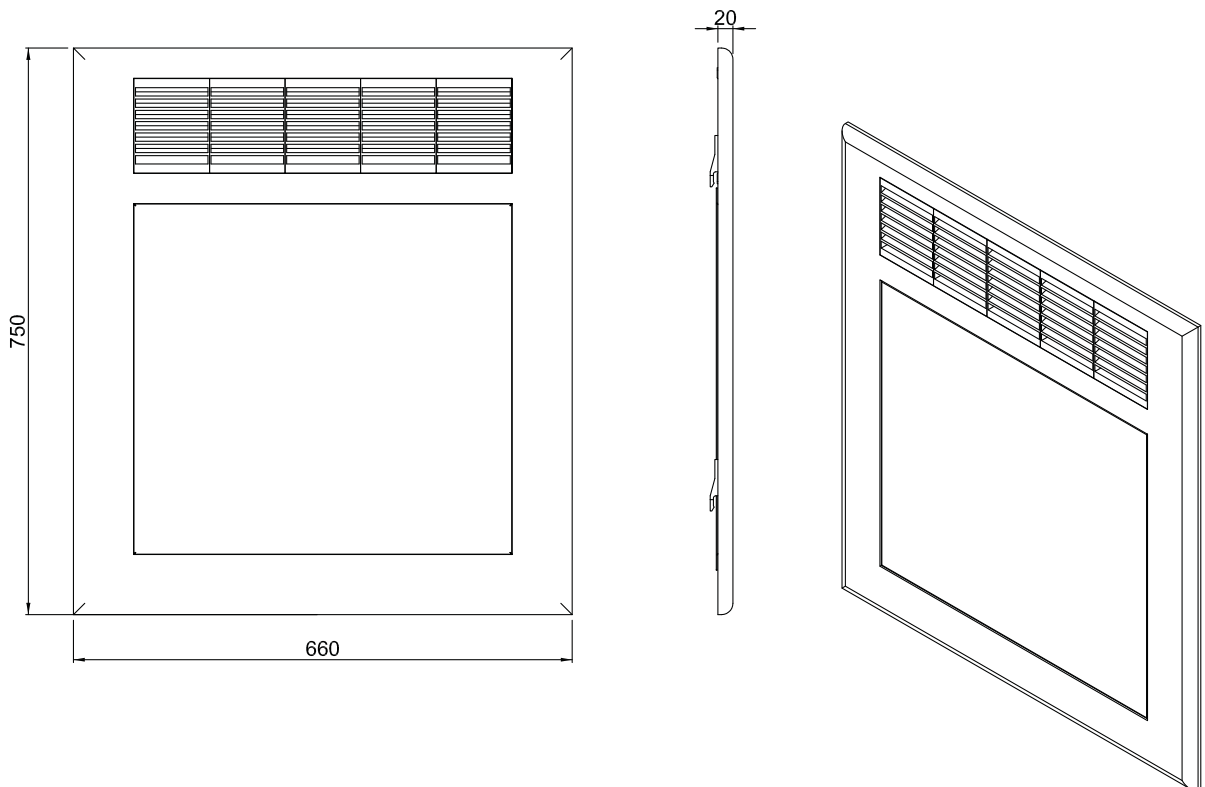



---

ESEX TECHNOLOGIES

VIA DELLE INDUSTRIE, 7 • CAP 31030 • VACIL DI BREDA DI PIAVE (TV)  
TEL. +39 0422 605 311

[Info@enex technologies.com](mailto:Info@enex technologies.com) • [www.enex technologies.com](http://www.enex technologies.com)

Technical data shown in this booklet are not binding.

The Company shall have the right to introduce at any time whatever modifications necessary to the improvement of the product.  
The reference languages for the whole documentation are Italian and English. The other languages are to be considered only as guidelines.

**enex**  
INNOVATION AS ENERGY

**kobol** Refrigeration  
INNOVATION AS ENERGY

**enex** Industrial  
INNOVATION AS ENERGY

**EMICON**  
INNOVATION AS ENERGY

**ETHRATECH**  
INNOVATION AS ENERGY

**kobol**  
HEAT EXCHANGERS NATURALLY

**MORGANA**  
HEAT EXCHANGERS NATURALLY

**ROENEST**  
HEAT EXCHANGERS NATURALLY