

Hidros

INNOVATION AS ENERGY



AN ENEX TECHNOLOGIES COMPANY

DEHUMIDIFIERS FOR RADIANT COOLING SYSTEMS WITH HEAT RECOVERY

FHE

SERIE



R134a



TECHNICAL MANUAL

Incorporated in this document are the following:

- Declaration of conformity
- Technical manual
- Dimensional drawing



RETAIN FOR FUTURE REFERENCE



Multiple instructions:
Consult the specific part



Read and understand
the instructions before
undertaking any work on
the unit

Reproduction, data storage and transmission, even partial, of this publication, in any form, without the prior written authorisation of the Company, is prohibited. The Company can be contacted for all inquiries regarding the use of its products.
The Company follows a policy of continuous product development and improvement and reserves the right to modify specifications, equipment and instructions regarding use and maintenance at any time, without notice.

Declaration of conformity

We declare under our own responsibility that the below equipment complies in all parts with the CEE and EN directives.
The declaration of conformity is enclosed to the technical booklet enclosed with the unit. The unit contains fluorinated greenhouse gases.

INDEX

1. INTRODUCTION	5
1.1 Preliminary information	5
1.2 Aim and content of the manual	5
1.3 How to store this manual	5
1.4 Manual updates	5
1.5 How to use this manual	5
1.6 Potential risks	6
1.7 General description of symbols use	7
1.8 Safety symbols used	8
1.9 Limitations and prohibited use	9
1.10 Unit identification	9
2. SAFETY	10
2.1 Warning re potentially hazardous toxic substances	10
2.2 Refrigerant handling	10
2.3 Prevention of inhalation of high vapor concentrations	11
2.4 Procedures in the event of accidental release of refrigerant	11
2.5 Main Toxicological information on the type of refrigerant used	11
2.6 First aid measures	11
3. TECHNICAL CHARACTERISTICS	12
3.1 Unit description	12
3.2 Accessories description	14
3.3 Main components	15
3.4 Aeratic circuit functioning principles	15
3.5 Refrigerant circuit layout	16
3.6 Operation mode	17
3.7 Technical Data	18
3.8 Hydraulic circuit pressure drops	19
3.9 Efficiency of the heat recovery	19
3.10 Fans	20
3.11 Operation limits	22
3.12 Sound data	23
3.13 Safety devices	24
3.14 Electric data	24
4. INSTALLATION	24
4.1 General safety guidelines and use of symbols	24
4.2 Health and safety Considerations	25
4.3 Personal protective equipment	25
4.4 Inspection	26
4.5 Storage	26
4.6 Unpacking	26
4.7 Lifting and handling	27
4.8 Location and minimum technical clearances	27
4.9 Condensate draining connections	28
4.10 Water coil hydraulic connection	28
4.11 How to vent the unit	28
4.12 Ductwork unit connection	29
4.13 Balancing and calibration of air flow	30
4.14 Serial interface card RS485 (INSE)	30
4.15 Filter extraction	30
4.16 Heat recovery extraction	30
4.17 Electric connections: preliminary safety information	31
4.18 Electrical data	32
4.19 Electric connections	32
5. UNIT START UP	33
5.1 Preliminary checks	33

5.2 Description of the control panel	34
5.3 Remote control panel.....	36
6. USE	38
6.1 Switch the unit on	38
6.2 Stop	38
6.3 Stand-by	38
6.4 How to change the set points	39
6.5 Acoustic signal silencing	40
6.6 Displaying during an alarm	40
6.7 Alarm reset.....	40
7. UNIT MAINTENANCE	40
7.1 General warnings.....	40
7.2 Drive access	41
7.3 Periodical checks.....	41
7.4 Refrigerant circuit repair	41
8. DECOMMISSIONING.....	42
8.1 Disconnect the unit	42
8.2 Disposal, recovery and recycling	42
8.3 RAEE Directive (Only UE)	42
9. DIAGNOSIS AND TROUBLESHOOTING	43
9.1 Fault finding	43
10.DIMENSIONAL DRAWINGS	44

1. INTRODUCTION

1.1 Preliminary information

Reproduction, storage or transmission of any part of this publication in any form, without the prior written consent of the Company, is prohibited.

The unit to which these instructions refer, is designed to be used for the the purposes described and to be operated in accordance with these instructions.

The Company will not be liable for claims for damage caused to persons, animals, material goods or property caused by improper installation, adjustment and maintenance or improper use. Any use not specified in this manual is prohibited.

This document is intended to provide information only and does not form a contract with third parties.

The Company pursues a policy of constant improvement and development of its products and therefore reserves the right to change the specifications and the documentation at any time, without notice and without obligation to update existing equipment.

1.2 Aim and content of the manual

These instructions are intended to provide the information required for the selection, installation, use and maintenance of the unit.

They have been prepared in accordance with the European Union laws and with the technical standards in force at the date of issue of the instructions.

The instructions contain all the necessary information to prevent any reasonably foreseeable misuse.

1.3 How to store this manual

The manual must be kept in a suitable place with easy access for users and operators, protected from dust and damp.

The manual must always accompany the unit during the entire life cycle of the same and therefore must be transferred to any subsequent user.

1.4 Manual Update

It is recommended that the manual is updated to the latest revision available.

If updates are sent to the customer they must be added to this manual.

The latest information regarding the use of its products is available by contacting the Company.

1.5 How to use this manual



The manual is an integral part of the unit.

Users or operators must consult the manual before performing any operation and especially so when transporting, handling, installing, maintaining, or dismantling the unit in order to eliminate uncertainty and reduce risk.



In these instructions symbols have been used (described in the following paragraphs) to draw the attention of operators and users to the operations that have a higher risk and which must be performed safely.

1.6 Potential Risks

Whilst the unit has been designed to minimize any risk posed to the safety of people who will interact with it, it has not been technically possible to eliminate completely the causes of risk. It is therefore necessary to refer to the requirements and symbolism below:

LOCATION OF RISK	POTENTIAL RISK	METHOD OF INJURY	PRECAUTIONS
Thermal heat exchangers.	Small stab wounds.	Contact	Avoid any contact, use protective gloves.
Fan and fan grilles.	Cuts, eye damage, broken bones.	Insertion of sharp objects through the grid while the fans are operating.	Never put objects through the protection grilles.
Internal component: compressors and discharge pipes	Burns.	Contact	Avoid any contact, use protective gloves.
Internal component: electric cables and metallic parts	Electrocution, severe burns.	Defect in the supply cable insulation, live metallic parts.	Adequate protection of power cables, ensure correct earthing of all metal parts.
External to unit: unit enclosure	Poisoning, severe burns.	Fire due to short circuit or overheating of the supply cable external to unit.	Size cables and mains protection system in accordance with iee regulations.
Low pressure safety valve.	Poisoning, severe burns.	High evaporating pressure causing a refrigerant discharge during maintenance.	Carefully check the evaporating pressure during the maintenance operations.
High pressure safety valve.	Poisoning, severe burns, hearing loss.	Activation of the high pressure safety valve with the refrigerant circuit open.	If possible, do not open the refrigerant circuit valve; carefully check the condensing pressure; use all the personal protective equipment required by law.
Entire unit	External fire	Fire due to natural disasters or combustions of elements nearby unit	Provide the necessary fire-fighting equipment
Entire unit	Explosion, injuries, burns, poisoning, folgoramento for natural disasters or earthquake.	Breakages, failures due to natural disasters or earthquake	Plan the necessary precautions both electrical (suitable differential magneto and electrical protection of the supply lines; greatest care during the connections of the metal parts), and mechanical (special anchors or seismic vibrations to prevent breakages or accidental falls).

1.7 General Description of Symbols Used

Safety symbols combined in accordance with ISO 3864-2:



BANNED

A black symbol inside a red circle with a red diagonal indicates an action that should not be performed.



WARNING

A black graphic symbol added to a yellow triangle with black edges indicates danger.



ACTION REQUIRED

A white symbol inserted in a blue circle indicates an action that must be done to avoid a risk.

Safety symbols combined in accordance with ISO 3864-2:



The graphic symbol “warning” is qualified with additional safety information (text or other symbols).

1.8 Safety symbols used



GENERAL RISK

Observe all signs placed next to the pictogram. The failure to follow directions may create a risk situation that may be injurious to the user.



ELECTRICAL HAZARD

Observe all signs placed next to the pictogram.

The symbol indicates components of the unit and actions described in this manual that could create an electrical hazard.



MOVING PARTS

The symbol indicates those moving parts of the unit that could create risk.



HOT SURFACES

The symbol indicates those components with high surface temperature that could create risks.



SHARP SURFACES

The symbol indicates components or parts that could cause stab wounds.



EARTH CONNECTION

The symbol identifies Earthing connection points in the unit.



READ AND UNDERSTAND THE INSTRUCTIONS

Read and understand the instructions of the machine before any operations.



RECOVER OR RECYCLE MATERIAL

1.9 Limitations and prohibited use

The machine is designed and built exclusively for the uses described in "Limitations of use" of the technical manual. Any other use is prohibited because it may pose a potential risk to the health of operators and users.



The unit is not suitable for operations in environments:

- excessively dusty or potentially explosive atmospheres;
- where there are vibrations;
- where there are electromagnetic fields;
- where there are aggressive atmospheres

1.10 Unit identification

Each unit has a rating plate that provides key information regarding the machine. The rating plate may differ from the one shown below as the example is for a standard unit without accessories. For all electrical information not provided on the label, refer to the wiring diagram. A facsimile of the label is shown below:

		Manufacturer: PD322111			
Via E. Mattei, 20 35028 Piove di Sacco PD - Italy +39 049 9731022 info@hidros.it www.hidros.eu					
1FHE.026K-2A Modello <i>Model</i>			123456 Matricola <i>Serial number</i>		
1 Categoria PED <i>PED Category</i>			21/2017 Data di fabbricazione <i>Manufacture date</i>		
R134A Tipo refrigerante <i>Refrigerant type</i>		2 Gruppo fluido <i>Fluid group</i>		1430 GWP	
C1 0,59 Kg Carica refrigerante <i>Refrigerant charge</i>		C2 C3 C4		0,84 ton CO ₂ Equivalente <i>CO₂ Equivalente</i>	
230V-1ph-50Hz Tensione-Fasi-Frequenza <i>Voltage-Phases-Frequency</i>		3,50 A F.L.A. (A)		0,60 kW F.L.L. (kW)	
LATO BASSA PRESSIONE LOW PRESSURE SIDE			LATO ALTA PRESSIONE HIGH PRESSURE SIDE		
10 bar PS			20,06 bar PS		
Min -30 °C		Max +130 °C		Min -30 °C	
Temperatura di progetto <i>Design temperature</i>		Max +130 °C		Temperatura di progetto <i>Design temperature</i>	
80 Kg Peso a vuoto <i>Weight</i>					
Contiene gas fluorurati ad effetto serra disciplinati dal protocollo di Kyoto Contains fluorinated greenhouse gasses covered by the Kyoto protocol					
					



The product label should never be removed from the unit.

2. SAFETY

2.1 Warning re potentially hazardous toxic substances

2.1.1 Identification of the Type of Refrigerant Fluid Used: R134a

- R134a: Tetrafluoroethane (HFC134a) 100% by weight CAS No.: 000811-97-2

2.1.2 Identification of the Type of Oil Used.

The lubricant used is polyester oil. Please refer to the information provided on the compressor data plate.



For further information regarding the characteristics of the refrigerant and oil used, refer to the safety data sheets available from the refrigerant and oil manufacturers.

Main Ecological Information Regarding the Types of refrigerants Fluids used.



ENVIRONMENTAL PROTECTION : Read the ecological information and the following instructions carefully.

2.1.3 Persistence and degradation

The refrigerants used decompose in the lower atmosphere (troposphere) relatively quickly. The decomposed products are highly dispersible and therefore have a very low concentration. They do not influence the photochemical smog which is not among the VOC volatile organic compounds (as stipulated in the guidelines to the UNECE). The constituent refrigerants of R407C (R32, R125 and R134a), do not damage the ozone layer. These substances are regulated under the Montreal Protocol (revised 1992) and regulations EC no. 2037/200 of 29 June 2000.

2.1.4 Effects of discharges

Discharges into the atmosphere of this product does not cause a long-term contamination.

2.1.5 Exposure controls and personal protection

Wear protective clothing and gloves, protect your eyes and face

2.1.6 Professional exposure limits

R134A
HFC-134a TWA 1000 ppm

2.2 Refrigerant handling



Users and maintenance personnel must be adequately informed about the possible risks of handling potentially toxic substances. Failure to follow such instructions can cause damage to personnel or to the unit.

2.3 Prevent inhalation of high vapor concentration

Atmospheric concentrations of refrigerant must be minimized and kept to a level that is below the occupational exposure limit. Vapor is heavier than air and can form dangerous concentrations near the ground where the ventilation rate is lower. Always ensure adequate ventilation. Avoid contact with open flames and hot surfaces as this can cause toxic and irritating decomposition products to form. Avoid contact between liquid refrigerant and the eyes or skin.

2.4 Procedures to be adopted in the event of accidental release of refrigerant

Ensure suitable personal protection (especially respiratory protection) during cleaning operations.

If deemed safe, isolate the source of the leak. If the leakage is small and if adequate ventilation is provided, allow the refrigerant to evaporate. If the loss is substantial ensure that measures are taken to adequately ventilate the area.

Contain spilled material with sand, earth or other suitable absorbent material.

Do not allow the refrigerant to enter drains, sewers or basements, as pockets of vapor can form.

2.5 Main Toxicological Information Regarding the Type of refrigerant used

2.5.1 Inhalation

A high atmospheric concentration can cause anaesthetic effects with possible loss of consciousness. Prolonged exposure may lead to irregular heartbeat and cause sudden death. Higher concentrations may cause asphyxia due to the reduced oxygen content in the atmosphere.

2.5.2 Contact with skin

Splashes of nebulous liquid can produce frostbite. Probably not hazardous if absorbed through the skin. Repeated or prolonged contact may remove the skin's natural oils, with consequent dryness, cracking and dermatitis.

2.5.3 Contact with eyes

Splashes of liquid may cause frostbite.

2.5.4 Ingestion

While highly improbable, may produce frostbite.

2.6 First Aid Measures



Adhere scrupulously to the warnings and first aid procedures indicated below.

2.6.1 Inhalation

Move the person away from the source of exposure, keep him/her warm and let him/her rest. Administer oxygen if necessary. Attempt artificial respiration if breathing has stopped or shows signs of stopping. If the heart stops, perform external heart massage. Seek medical assistance.

2.6.2 Contact with skin

In case of contact with skin, wash immediately with lukewarm water. Thaw tissue using water. Remove contaminated clothing. Clothing may stick to the skin in case of frostbite. If irritation, swelling or blisters appear, seek medical assistance.

2.6.3 Contact with eyes

Rinse immediately using an eyewash or clean water, keeping eyelids open, for at least ten minutes. Seek medical assistance.

2.6.4 Ingestion

Do not induce vomiting. If the injured person is conscious, rinse his/her mouth with water and make him/her drink 200-300ml of water. Seek immediate medical assistance.

2.6.5 Further medical treatment

Treat symptoms and carry out support therapy as indicated. Do not administer adrenaline or similar sympathomimetic drugs following exposure, due to the risk of cardiac arrhythmia.

3. TECHNICAL CHARACTERISTICS

3.1 Unit description

The dehumidifiers with heat recovery of high efficiency series FHE were designed to provide dehumidification and fresh air in a residential area with very high energy efficiency, combined with radiant cooling systems. The units have been designed to grant the dehumidification neither under conditions of thermally neutral air or in terms of air-cooled, managing small air flow thus avoiding annoying tiny air currents typical of traditional air conditioning systems. The units consist of a direct expansion cooling system combined with a cross flow heat exchanger highly efficient, designed for heat recovery and air exchange environment in compliance with applicable regional and national laws.

3.1.1 Frame

All units are made from hot-galvanized thick sheet metal, painted with polyurethane powder enamel and stoved at 180°C to ensure the best resistance against the cor-rusions. The frame is self-supporting with removable panels. The drip tray is made in painted galvanized steel and it is present in all units. The standard colour is RAL 9016.

3.1.2 Refrigerant circuit

The refrigerant circuit is made by using international primary brands components and according to ISO 97/23 concerning welding procedures. The refrigerant gas used in is R134a.

3.1.3 Compressor

The compressor is alternative type equipped and thermal overload protection by a klixon embedded in the motor winding. It's mounted on rubber vibration dampers to reduce the noise.

3.1.4 Heat exchangers

The heat exchangers are made of copper pipes and aluminium fins. The diameter of the copper pipes is 3/8" and the thickness of the aluminium fins is 0,1 mm.

3.1.5 Heat recovery

Hexagonal cross-flow regenerator with aluminum plates, high efficiency (90%).

3.1.6 Water coil

All units are supplied, as standard, with a water coil, made of copper pipes and aluminum fins. The copper pipes have a diameter of 3/8", the thickness of the aluminum fins is 0,1 mm. The tubes are mechanically expanded into the aluminum fins to improve the heat exchange factor. The water coil is used to improve the dehumidification capacity in summer mode, while it is being used as a heating coil in winter mode. All units are supplied with a built-in modulating 3-way valve which keeps constant the air supply temperature under varying external air conditions.

3.1.7 Water condenser

Type-brazed plate, made of stainless steel AISI 316; The water condenser is used in the summer season as cooling integration.

3.1.8 Fans

The supply fan is centrifugal type, double inlet with forwards blades, with EC Fan motor directly connected. The exhaust fan is plug fan type with backwards blades, with EC fan motor directly connected.

3.1.9 Air filter

It's supplied standard with the unit. It's made of filtering material in synthetic fibre without electrostatic charge. It can be removed for differential disposal, class G4, according to EN 779:2002.

3.1.10 Microprocessor

All FHE units are supplied with an advanced software for the complete control of the hydronic and air distribution side.

The software can manage:

- The management of the operation according to a probe of temperature and humidity.
- Activation of the dehumidification based on the pre set humidity conditions.
- Activation of winter or summer sensible load integration, according to the summer or winter set point
- Management of supply air temperature trough discharge limit probe sensor (standard).
- Modulating valve for the proper management of the water battery power
- Ventilation Management directly from built-in timer in the microprocessor (optional).
- Management dumper
- Machine Alarm display
- Supervisor and BMS connection trough serial card RS485 (Optional) a/o XWEB Module (Optional).
- Clogged filters management (optional).
- Antifreeze management.
- Summer/Winter commutation.

3.1.11 Electrical panel

The switch board is made according to norms CEE 73/23 and 89/336 . The accessibility to the board is possible after removing the front panel of the unit and the OFF positioning of the main switch. The board is prepared for connection to the main power supply and the control signals, it is equipped with a terminal board with voltage free contacts for :

remote ON - OFF ,

Summer / Winter (Open = Summer ; Closed = Heating)

Hygrostat (only in the version with Remote mechanical Thermostat - hygrostat)

Thermostat (only in the version with Remote mechanical Thermostat - hygrostat).

The electrical panel is supplied with 3 trimmers adjustment for the EC fans; they are used in the system to calibrate the air flow of the fans as a function of the pressure drops of the plant.

- Trimmer for exhaust fan airflow set
- Trimmer for supply fan minimum airflow
- Trimmer for supply fan maximum airflow.

3.1.12 Control and Protection Devices

All units are supplied with the following control and protection devices:

1. Defrost thermostat; which signals to the microprocessor control, the necessity to make the defrost cycle and determines its duration.
2. Temperature sensor; it is a device that signals to the electronic control the overcoming limits (water inlet temperature to the water coil). In such a situation the operation of the compressor is disabled, by leaving the fan only in operation, when the conditions are restored within the limits, the compressor will restart. This feature is normally used in winter operation. the probe blocks the operation of the compressor with a water temperature above of 35 °C. The possible use of the dehumidifier just as a heating device (so, compressor OFF) in the winter period necessarily requires the use of a remote thermostat with seasonal summer winter change over (not supplied).

3.1.13 Built in electronic sensor (RGDD)

Built-in electronic temperature / humidity probe. Factory fitted in the unit.

3.1.14 Test

All the units are fully assembled and wired at the factory, carefully evacuated and dried after leak tests under pressure and then charged with ecologic refrigerant. They are all fully operational tested before shipment. They all conform to European Directives and are individually marked with the CE label and provided with Conformity Declaration.

3.2 Accessories description

3.2.1 Serial interface card RS485 (INSE)

This interface card enables the controller to communicate with other devices using Modbus protocol.

3.2.2 Remote control panel (PCRL)

This panel can be mounted up to 50m (maximum) from the unit and replicates all of the control functions. It is connected using a twin cable of 2.5 mm² section.

3.3 Main components

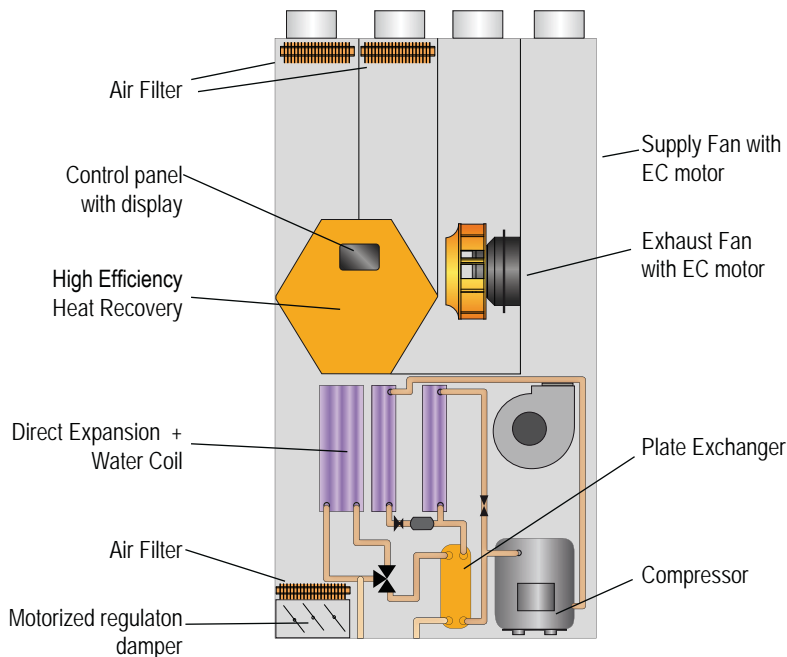

3.4 Aeraulic circuit functioning principles

FHE units can operate with a flow rate of outdoor air from 80 to 130 m³/h, to ensure sufficient supply air changes in the room having a variable volume by 460 m³ (0.3 vol/h), in compliance with regional and national regulations. The air flow rate of discharge can vary from 80 to 130 m³/h in the winter mode, and is fixed to 260 m³/h in summer mode.

The cross-flow heat exchanger of high efficiency is designed to ensure a recovery rating of 90% in terms of air temperature -5°C and air temperature 20°C. The stale air is expelled from the environment by the fan (1), while the outside air is sucked through the fan (2).

The proper balance of air flows is ensured by the damper (3) that handles both the balance of flows of air that the air flow recirculation summer.

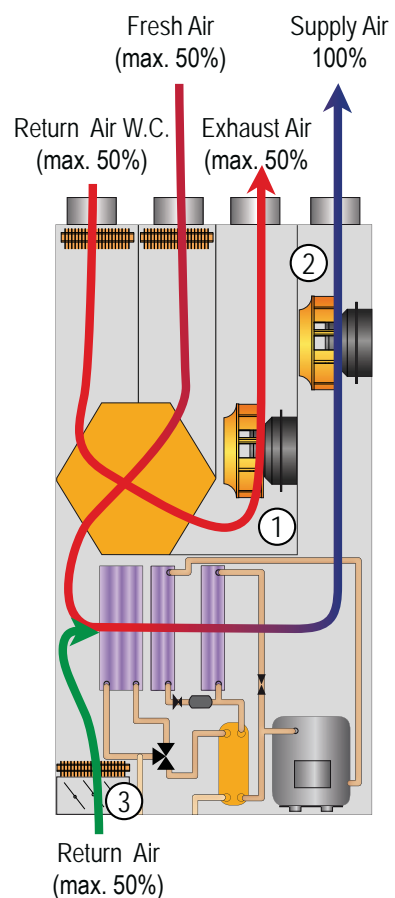

3.5 Refrigeran circuit layout

3.5.1 Refrigerant circuit functioning principles:

The functioning of the dehumidifier model FHE is as follows: the fan takes the air humid from the ambient trough the fan (7) and it's made go through the filter (1) and the cross-flow heat (12) pre-cooling water coil (2) where it's cooled and brought to a condition closed to saturation. Now it passes through the evaporating coil (3) where it's fatherly cooled and dehumidified. At this time the functionality mode may be. The air passes now through the condensing coil (5) where it's post heated (with a constant humidity) and in the post-cooling coil (6) where it's reported to the required conditions.

Dehumidification with neutral air :

The cooling system works partially in the water through the heat exchanger (10) and partially in the air with the heat exchanger (5) which will then make a post-heating at constant humidity blowing air in in the room in thermally neutral conditions.

Dehumidification with cooling:

The cooling circuit, in this case, performing works 100% of the condensation in the water through the heat exchanger (10), the heat exchanger (5) is intercepted by the valve (6) and the air supplied in the room is the same as leaving the evaporator coil (3), cold and dried.

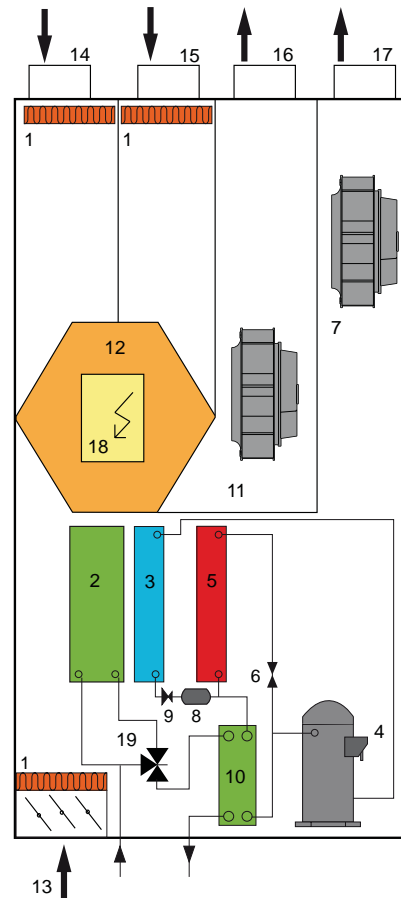

1	Air filter	10	Water condenser
2	Pre-Cooling coil	11	Exhaust fan with EC motor
3	Evaporator	12	High efficiency cross-flow heat recovery
4	Compressor	13	Return motorized damper
5	Air Condenser	14	WC exhaust air
6	Solenoid Valve	15	Fresh air
7	Supply fan with EC	16	Exhaust Air
8	Dryer Filter	17	Electrical Panel
9	Body rolling	18	Modulating 3-way valve

3.6 Operation mode

3.6.1 Summer operation (COMPRESSOR ON)

Whit this selected mode the unit renews the ambient air with the outside through the heat exchanger for high efficiency, air flow is increased so as to allow operation of refrigerant circuit; for this purpose the r recycling dumper will be open, the supply fan is operated at maximum capacity and the unit works with external air and partial recirculation.

The possible functions in this configuration are

- Renewal + Air Dryers neutral: The condensing unit partially in air and partially in the water through the condenser plate, obtaining dry air and thermally neutral.
- Renewal + Dehumidification with cooling: The unit operates with 100% of the condensation water, obtaining dry and cooled air.

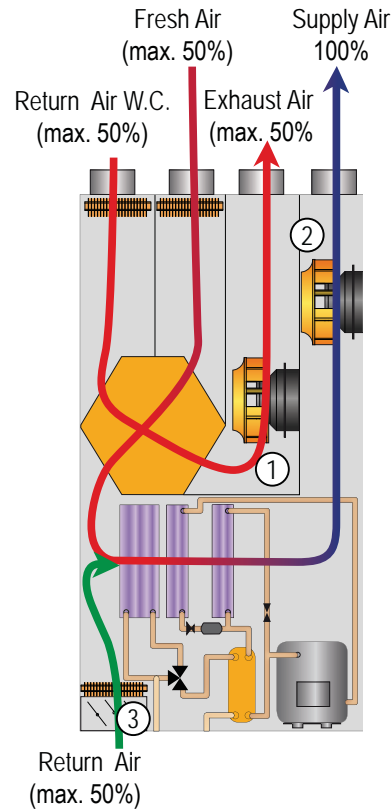

The FHE units cannot operate without the integration of cold/hot water coil. In the case of low water flow or absence the unit is kept in stand-by and the safety devices are activated.

3.6.1 Winter operation and middle season (COMPRESSOR OFF)

Whit this selected mode, the unit renews the ambient air with the outside through the heat exchanger of high efficiency.

The air flow is reduced to the value required by the standard ($0.3 \div 0.5$ vol / h), the recirculation damper is closed and the unit operates with 100% fresh air.

The possible functions in this configuration are

- Renewal with heated air: The compressor is switched off, the battery can be supplied with hot water from radiant system, (even due to the high efficiency of the heat exchanger, is able to obtain a supply air temperature 17°C , without using hot water and ambient air temperature of -5°C), and behaves like a normal air handling with recovery.

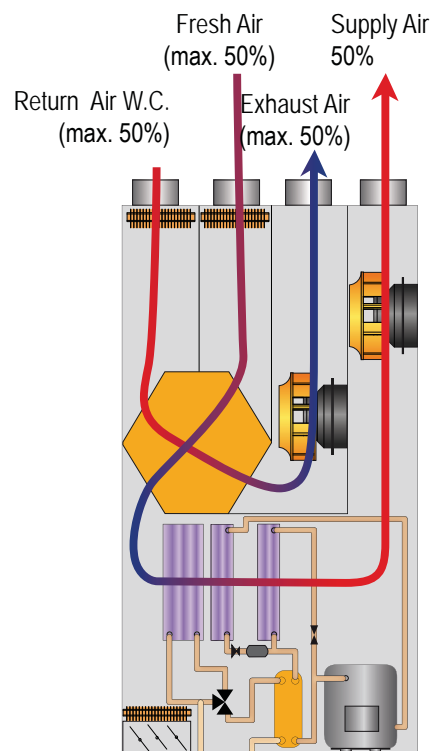

In winter mode, the FHE units have the compressor off and operate as a heating device with high efficiency heat recovery .

3.7 Technical Data

FHE		26
Useful dehumidification capacity (from the net hygroscopic content of the external air) ⁽¹⁾	l/24h	30,5
Total cooling Power (latent + sensible) ⁽¹⁾	W	1380
Recovered winter heating power ⁽²⁾	W	950
Efficiency winter recovery ⁽²⁾	%	90
Efficiency summer recovery ⁽¹⁾	%	70
Power supply	V/Ph/Hz	230/1/50
Compressor absorbed power ⁽¹⁾	W	395
Supply fan absorbed power: minimum÷nominal÷maximum	W	10 ÷ 30 ÷ 86
Return fan absorbed power	W	11 ÷ 22 ÷ 43
Supply fan nominal useful prevalence	Pa	50 ÷ 140
Return fan nominal useful prevalence	Pa	50 ÷ 140
Min-max coil water flow	l/h	150 - 250 ÷ 400
Min-max water pressure drop	kPa	15
Outdoor air flow	m ³ /h	80 ÷ 130
Supply air flow	m ³ /h	130 ÷ 260
Refrigerant		R134a
Global warming potential (GWP)		1430
Refrigerant charge	kg	0,59
Equivalent CO2 charge	t	0,84
Sound power ⁽³⁾	dB(A)	47
Sound Pressure ⁽⁴⁾	dB(A)	33

Performance refer to the following conditions:

(1) Room Temp. 26°C; 65% RU; Ambient Temp. 35°C; 50% RU; Fresh Air System volume 130 m³/h; Water IN 15°C, Water Flow 250 l/h.

(2) Ambient Temp. -5°C; 80% RU; Room Temp. 20°C; Fresh Air system at maximum.

(3) Sound Power level according to ISO 9614.

(4) Sound Pressure level measured at 1 mt from the unit in free field conditions according with ISO 9614, at the normal working conditions.

3.8 Hydraulic circuit pressure drops

The graphics below show the pressure drops of the hydraulic circuit of the FHE unit; They include the water coil, the plate heat exchanger and the 3 way modulating valve.

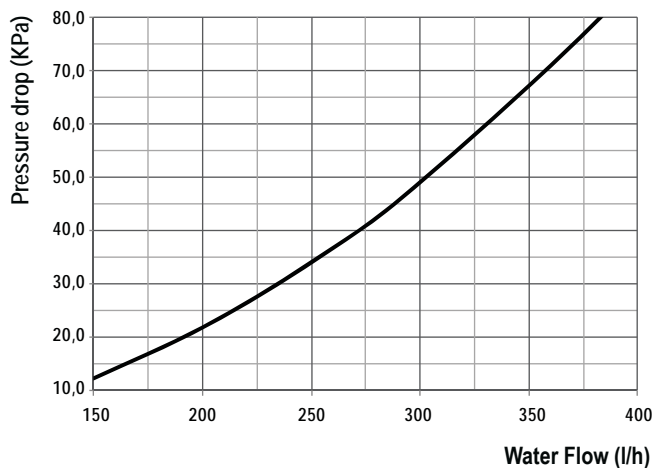

3.9 Efficiency of the heat recovery

WINTER (Room conditions 20°C, 50% u.r. - Ambient conditions -5°C, 80% u.r.)

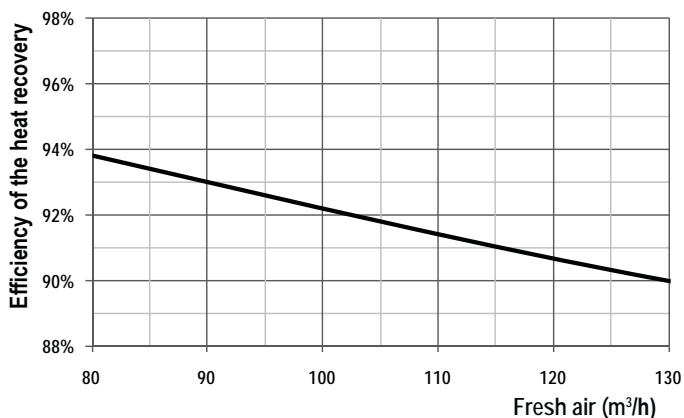

SUMMER (Room conditions 26°C, 60% u.r. - Ambient conditions 35°C, 50% u.r.)

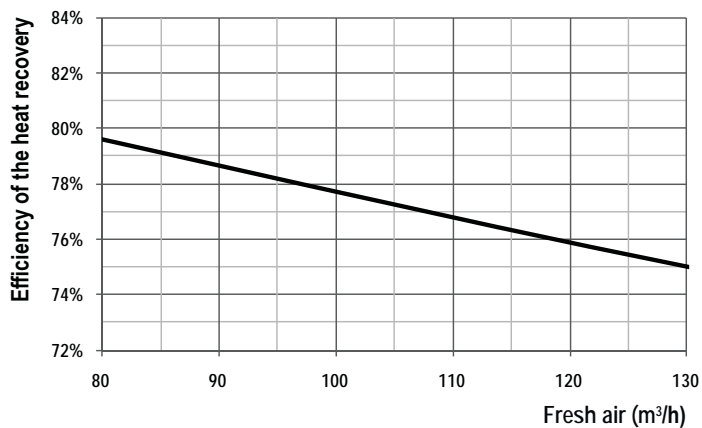

3.10 Fans

Supply fan

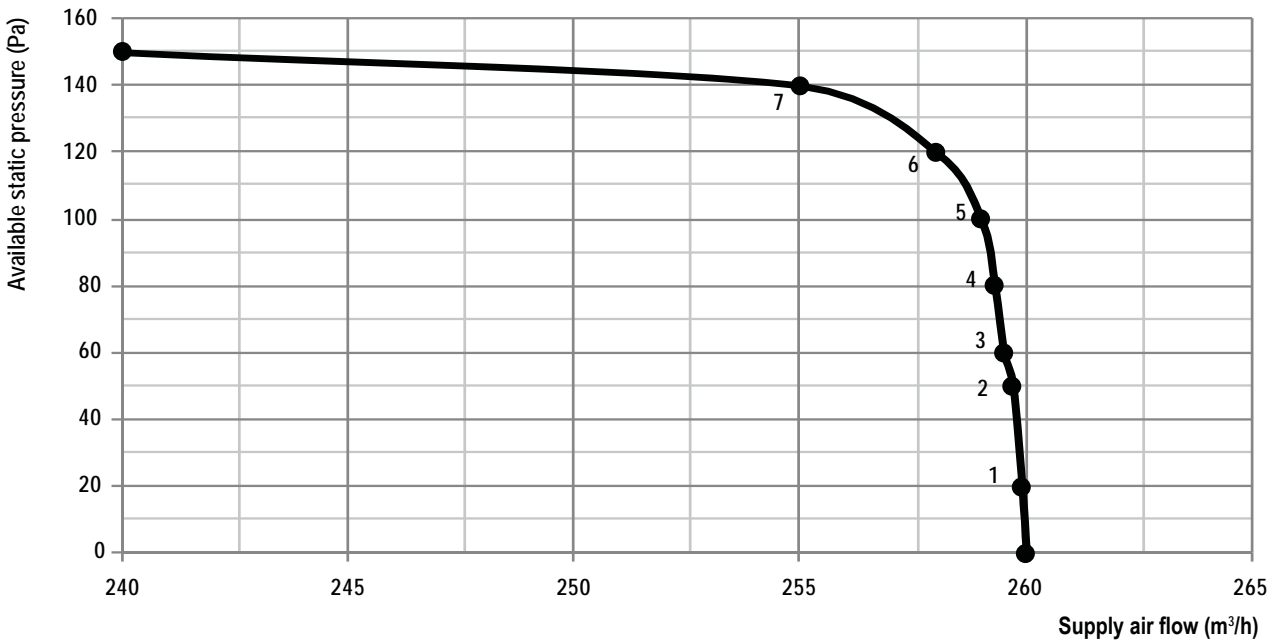

Input power	1	2	3	4	5	6	7
260 m³/h	18W	30W	36W	40W	46W	51W	60W

Exhaust fan

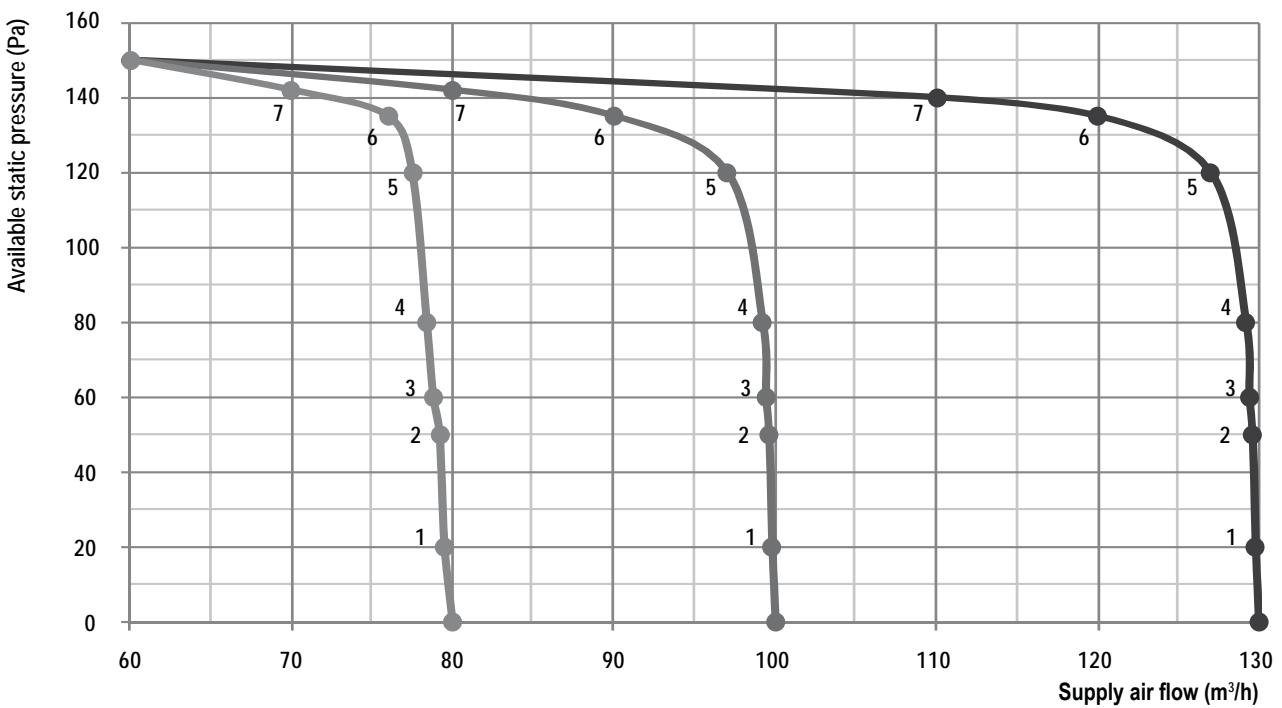

Input power	1	2	3	4	5	6	7
80 m³/h	10W	11W	11W	12W	12W	12W	12W
100 m³/h	11W	13W	15W	15W	17W	18W	18W
130 m³/h	11W	13W	15W	19W	22W	30W	34W

3.11 Operation limits

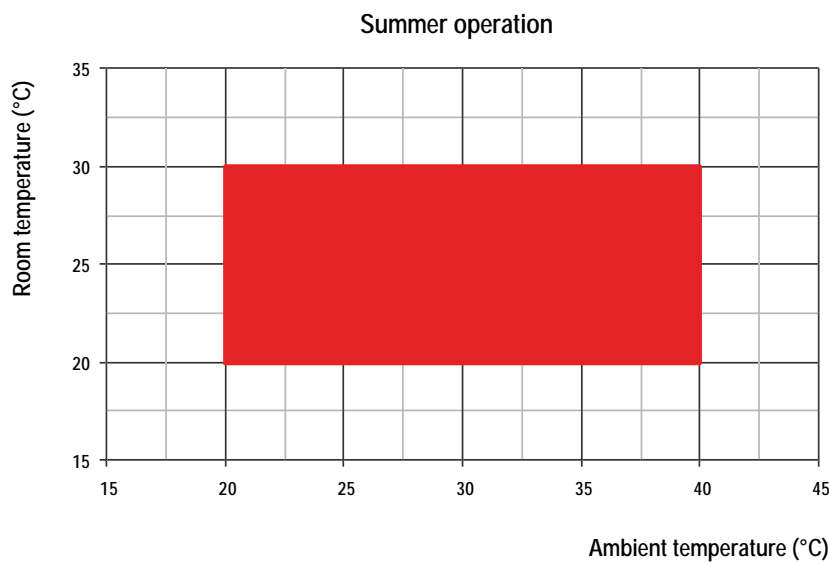
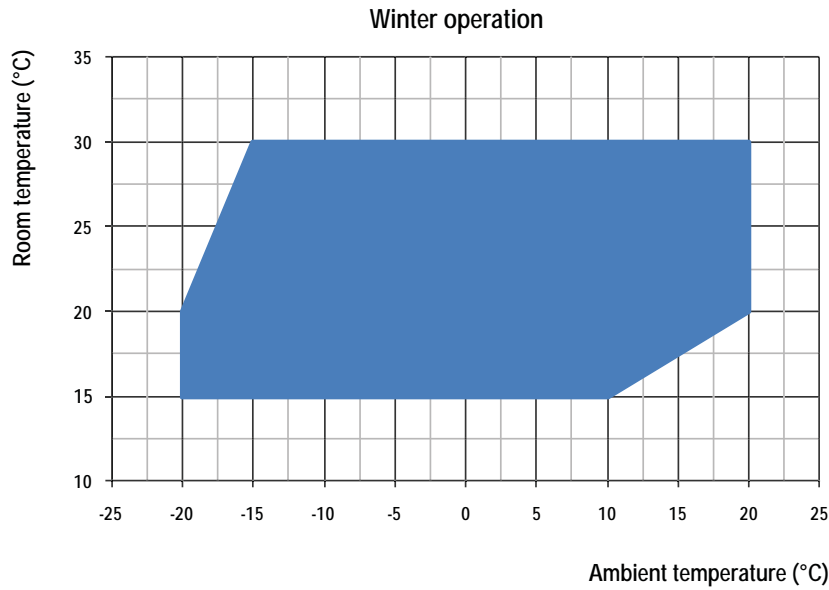

The units are designed and manufactured to work with relative humidity from 40% a 90%.



The units **MUST** be used within the operation limit indicated in the diagrams. The warranty will be invalidated if the units are used in ambient conditions outside the limits reported. If there is the necessity to operate in different conditions, please contact our technical office.



The units are designed and manufactured to work with ambient temperatures from 10°C to 50°C



The units are designed to operate within false ceiling and/or heated technical room. The units are **NOT** suitable for outdoor installations and / or technical room w/o heat (attics, rooms communicating with the outside) as it may form condensation on the walls and inside the unit cabinet causing damages.

3.12 Sound Data

The noise of the FHE unit is defined mainly by the number of revolutions of the fans (responsible for the greater part of the sound power generated by the unit). Obviously, for a given air flow rate, the number of revolutions of the fans will be smaller if the required static pressure will be low, while it will be higher (and therefore with greater noise level) in case of highest static pressure requirement. The table below shows the trend of sound levels according to some operating points (model / static pressure) of the unit:

Sound Data											
Mod.26	Pa	Octave band (Hz)								Lw (A)	Lp (A)
		63	125	250	500	1K	2K	4K	8K	dB(A)	dB(A)
		dB(A)	dB(A)	dB(A)	dB(A)	dB(A)	dB(A)	dB(A)	dB(A)		
7	140	68,1	59,3	53,2	51,7	50,6	45,2	41,8	32,7	55,0	41
6	120	66,1	57,3	51,2	49,7	48,6	43,2	39,8	30,7	53,0	39
5	100	65,1	56,3	50,2	48,7	47,6	42,2	38,8	29,7	52,0	38
4	80	63,1	54,3	48,2	46,7	45,6	40,2	36,8	27,7	50,0	36
3	60	61,1	52,3	46,2	44,7	43,6	38,2	34,8	25,7	48,0	34
2	50	60,1	51,3	45,2	43,7	42,6	37,2	33,8	24,7	47,0	33
1	20	59,1	50,3	44,2	42,7	41,6	36,2	32,8	23,7	46,0	32

Lw: Sound power level according to ISO 9614.

Lp: Sound Pressure level measured at 1 mt from the unit in free field conditions according with ISO 9614, ducted unit.

3.13 Safety devices

3.11.1 High pressure switch

The high pressure switch stops the unit when the condensing pressure is higher than the set value. The restart is manual (you need to press the button on the pressure switch) and it can be carried out only when the pressure is under the value indicated by the differential set.

3.11.2 Defrost thermostat

It's a device which signals to the electronic control, the necessity to make the defrost cycle. Once the defrost cycle is activated, the defrost thermostat determines also its conclusion.

3.11.3 Defrost probe

It is a device that signals to the electronic control the necessity to activate the defrost operation. Once the defrost cycle is activated, the NTC probe defrost determines also its conclusion (used in versions without electronic probe of temperature and humidity).

3.11.4 Defrost

The frost on the coil, obstructs the air flow, reduces the available exchange area and consequently the unit performances and can seriously damage the system. All the units are supplied, standard, with a control which defrost automatically the heat exchanger if necessary. This control provides a temperature probe (defrost thermostat) on the unit evaporator. When the defrost cycle is required, the microprocessor control (according to set parameters) starts working (the yellow led turns on) according to these modalities:

- air defrost: the compressor is switched off while the fan keeps on working.

For both modalities, at the end of the defrost cycle, there is the dripping time.

For the model GH50-50W, the defrost is cyclical (the microprocessor makes the defrost cycle every 30 minutes), for the GH100-200, both air cooled and water cooled, the defrost cycle is made in relation to the defrost panel.

3.14 Electric data

Electric data					
Power supply	V/~/Hz	230/1/50	Control circuit	V/~/Hz	24/1/ 50
Auxiliary circuit	V/~/Hz	230/1/50	Fans power supply	V/~/Hz	230/1/50

4. INSTALLATION

4.1 General safety guidelines and use of symbols



Before undertaking any task the operator must be fully trained in the operation of the machines to be used and their controls. They must also have read and be fully conversant with all operating instructions.



All maintenance must be performed by TRAINED personnel and be in accordance with all national and local regulations.



The installation and maintenance of the unit must comply with the local regulations in force at the time of the installation.



Avoid contact and do not insert any objects into moving parts.

4.2. Health and safety Considerations



The workplace must be kept clean, tidy and free from objects that may prevent free movement. Appropriate lighting of the work place shall be provided to allow the operator to perform the required operations safely. Poor or too strong lighting can cause risks.



Ensure that work places are always adequately ventilated and that respirators are working, in good condition and comply fully with the requirements of the current regulations.

4.3 Personal protective equipment



When operating and maintaining the unit, use the following personal protective equipment listed below, required by law.



Protective footwear.



Eye protection.



Protective gloves.



Respiratory protection.



Hearing protection.

4.4 Inspection

When installing or servicing the unit, it is necessary to strictly follow the rules reported on this manual, to conform to all the specifications of the labels on the unit, and to take any possible precautions of the case. Not observing the rules reported on this manual can create dangerous situations. After receiving the unit, immediately check its integrity. The unit left the factory in perfect conditions; any eventual damage must be questioned to the carrier and recorded on the Delivery Note before it is signed. The company must be informed, within 8 days, of the extent of the damage. The Customer should prepare a written statement of any severe damage.

Before accepting the unit check:

- The unit did not suffer any damage during transport;
- The delivered goods are conforming to what shown in the delivery note.

In Case of Damage

- List the damage on the delivery note
- Inform the Company of the extent of the damage within 8 days of receipt of the goods. After this time any claim will not be considered.
- A full written report is required for cases of severe damage.

4.5 Storage

Units should be stored under cover and ideally, should remain in their packaging. The tools that are supplied for opening the electric box should be formally transferred to the person responsible for the plant.

4.6 Unpacking



Packaging could be dangerous for the operators.

It is advisable to leave packaged units during handling and remove it before the installation.
The packaging must be removed carefully to prevent any possible damage to the machine.
The materials constituting the packaging may be different in nature (wood, cardboard, nylon, etc.).



The packaging materials should be separated and sent for disposal or possible recycling to specialist waste companies.

4.7 Lifting and handling

When unloading the unit, it is strongly recommended that sudden movements are avoided in order to protect the refrigerant circuit, copper tubes or any other unit component. Units can be lifted by using a forklift or, alternatively, using belts. Take care that the method of lifting does not damage the side panels or the cover. It is important to keep the unit horizontal at all time to avoid damage to the internal components.

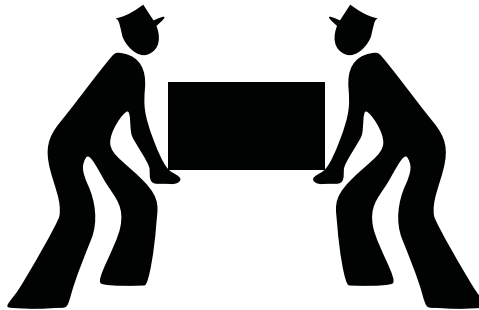

4.8 Location and minimum technical clearances



The unit has to be installed such that maintenance and repair is possible. The warranty does not cover costs for the provision of lifting apparatus, platforms or other lifting systems required to perform repairs during warranty period.



The installation site should be chosen in accordance with EN 378-1 and 378-3 standards. When choosing the installation site, all risks caused by accidental refrigerant leakage should be taken into consideration.

In the drawing the installation type is illustrated. It is important not to cover the top and bottom part of the unit to allow the connections and the frontal part to allow the cleaning and the replacement of the air filters, the control circuit, the maintenance of the electrical panel.

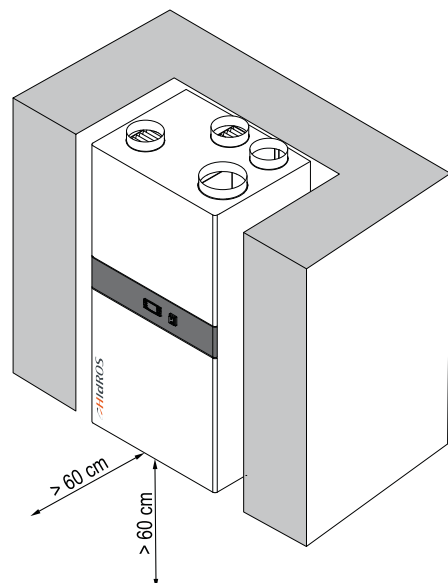

4.9 Condensate draining connections

Condensate draining should be done with a rubber pipe passing through the condensate draining connection located on the suction side of the unit. The discharge hole is 20mm diameter.

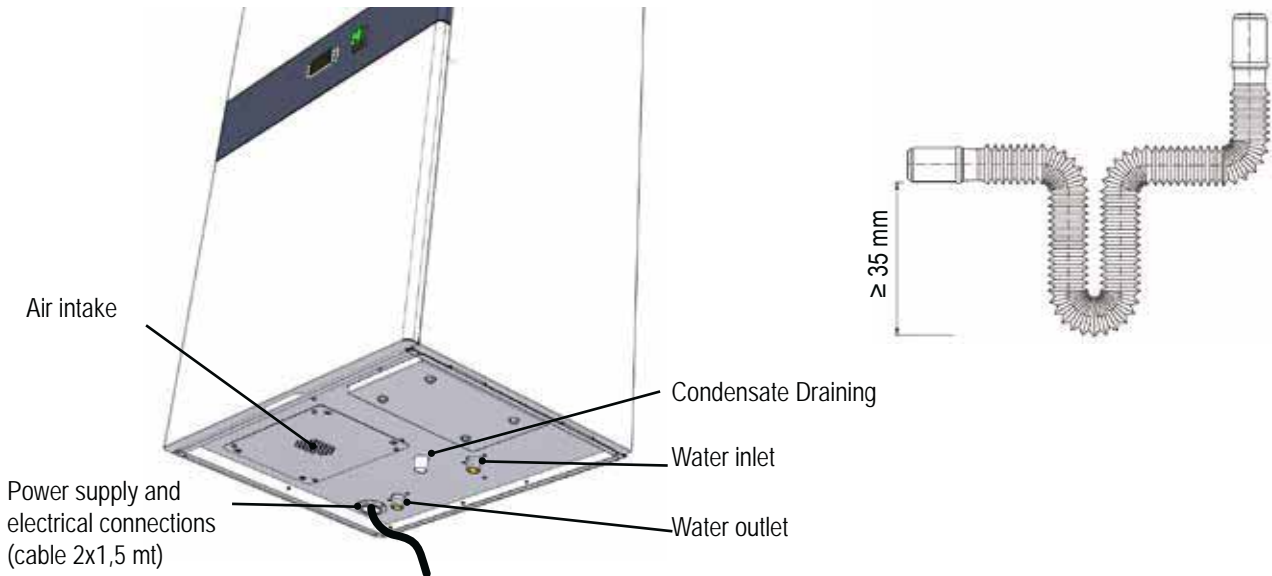

On the condensate discharge pipe it must be installed a syphon with a minimum height equal to the suction pressure of the fan, in any case never less than 35mm.

4.10 Water coil hydraulic connection

The dehumidifier is connected to the cooled water plant to grant the inlet in ambient of air in neutral conditions. On the units the connection is done using the female gas attacks 1/2" always present on the unit.



We recommend to power the unit with a dedicated water pump for a correct operation. It is strongly recommended to connect the unit upstream of the system manifold to ensure a proper waterflow (see illustration) .

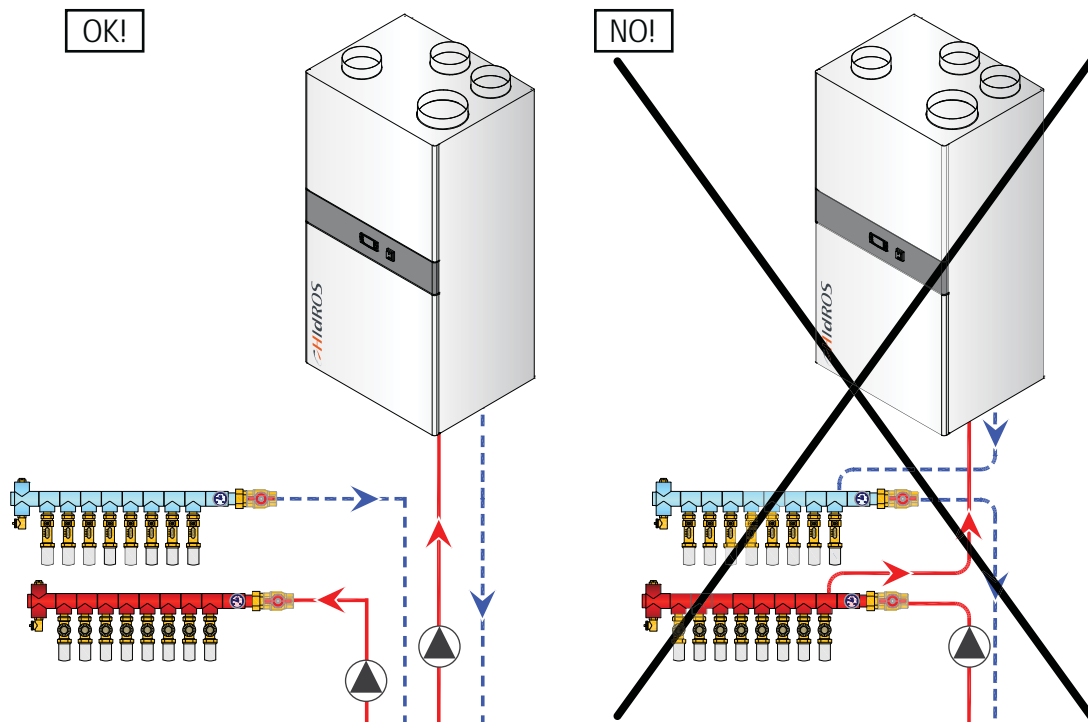



The inlet maximum water temperature allowed is 50°C.
The inlet maximum water temperature allowed is 10°C.



È fortemente consigliato collegare l'unità a monte del collettore dell'impianto in modo da assicurare la corretta alimentazione idrica.

4.11 How to vent the unit

For a correct operation of the system it is mandatory to remove the air from the hydraulic circuit. To do that it's recommended to use the proper vent valve positioned in front of the unit (see picture).

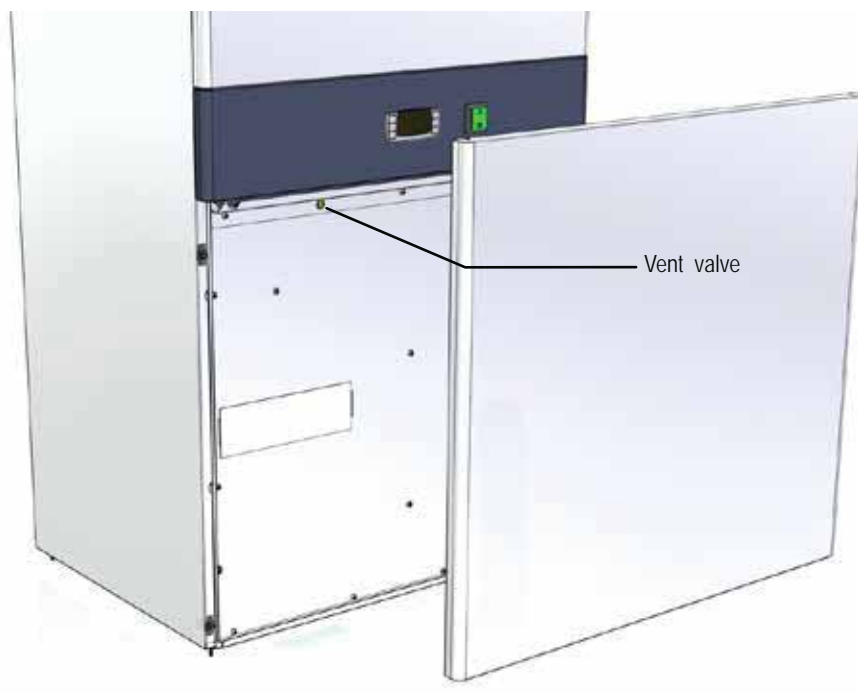

4.12 Ductwork unit connection

The FHE units must be connected to the air ducts in order to supply the treated clean air in the bedrooms and the living room and return air from the polluted rooms (kitchen, bathrooms). The air transfer through the different rooms generally occurs through the gaps under doors, and are not, as a rule, requested return air grilles. A typical example of air distribution is shown in the following scheme:

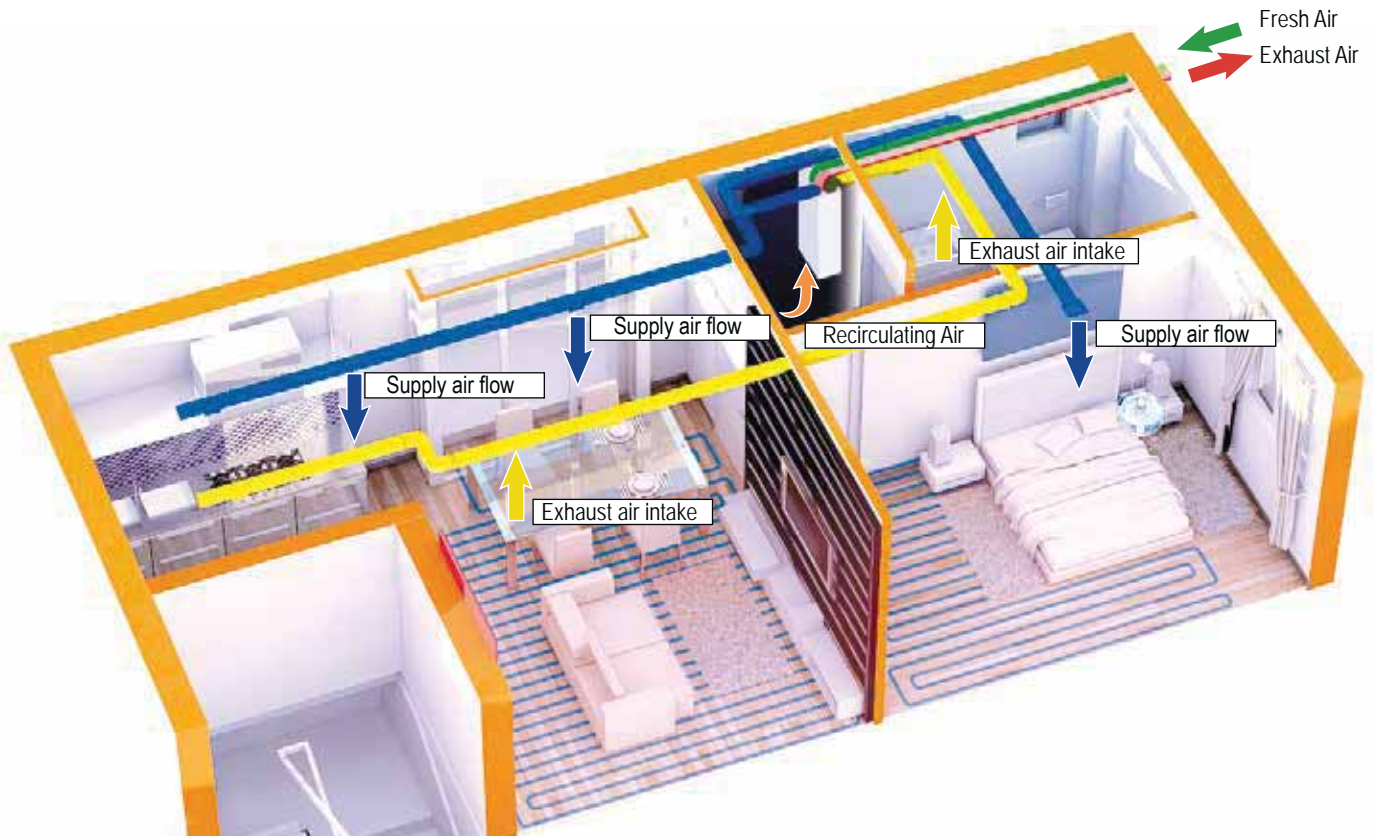

In order to enable the proper operation of the unit it is important to ensure a constant air flow, very close to the nominal value. The maximum allowed deviation is +/- 10%. When commissioning the unit, check first the airflow rate and change, if necessary, the setting of the trimmers of the fans according to the specific plant requirements (ducts length / required static pressure).

RECOMMENDED AIR SPEED				
Model	Ø Distribution duct (mm)	Air flow (m ³ /h)	Area (m ²)	Air speed (m/s)
FHE 26	160	260	0,0201	3,6
	Ø Return and exhaust ducts (mm)	Air flow (m ³ /h)	Area (m ²)	Air speed (m/s)
FHE 26	125	80	0,0123	1,8
	Ø Return and exhaust ducts (mm)	Air flow (m ³ /h)	Area (m ²)	Air speed (m/s)
FHE 26	125	100	0,0123	2,3
	Ø Return and exhaust ducts (mm)	Air flow (m ³ /h)	Area (m ²)	Air speed (m/s)
FHE 26	125	130	0,0123	3,0

4.13 Balancing and calibration of air flow

For a proper operation of the unit it is necessary to balance the air flow in the different sections of ductworks as having generally paths with different lengths you will have to inhomogeneous pressure loss and, consequently, different air flow rates. In fact, in the absence of adequate balancing of the pressure drops, for example by referring to the diagram in paragraph 4.2, we will have high air flow in point 1, slightly lower than the point 2 and very low at point 3. The same can be said of the points 4, 5 and 6.

To balance the pressure drops of the ductworks we will act on the calibration grids placed in the various supply and return grills (Component not supplied from the Company) adjusting the section of the grid: the greater diameter, lower pressure drop, greater air flow. It carried out the balancing of the system you will have to proceed with the calibration of the unit air flow, by adjusting the built in trimmers.

4.13.1 Supply and exhaust fan adjusting trimmers



All units are factory calibrated with the nominal air flow values (see table at par. 3.7) and available static pressure of 50 Pa.

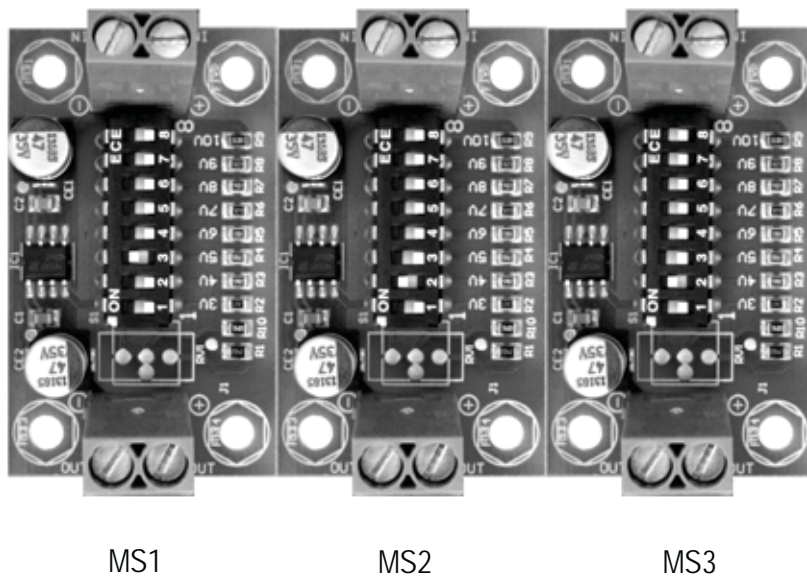

MS1 : trimmer of the supply fan in summer mode.

MS2 : trimmer of the supply fan in winter mode.

MS3 : trimmer of the exhaust fan.

As we see in the following picture, the trimmer has a single measurement range:



Indicatively it can be considered that the displacement of the trimmer from one number to the next or previous, leads to an increase / decrease of the available pressure of 15 Pa at the nominal air flow .



The factory settings are: PT1 : 5 ; PT2 : 4 ; PT3 : 4 .



For the purpose of noise reduction , it is necessary that the air velocity in the ducts NEVER exceed 4 m / sec . Above this airspeed it greatly reduces the dehumidification capacity of the unit and increases the risk of condensation of water entrainment in the air ducts, with potential damages to the furniture and / or floors.

4.14 Serial interface card RS485 (INSE)

Supervision system interface serial board (MODBUS RS485 available only) The installation of the card will allow the unit to be plugged in and connected to a system with MODBUS protocol. This system allows you to remotely monitor all parameters of the unit and change their values. The serial interface board is normally fitted at the factory, where it is provided separately is necessary to respect the polarity of the wiring as shown in the diagram. Any reversal of polarity will result in the non-functioning unit. The supervision connectivity cable must be telephone one type 2x0, 25 mm². The unit is configured at the factory with serial address 1. In case of using the MODBUS system, you can request the list of variables by contacting the assistance.

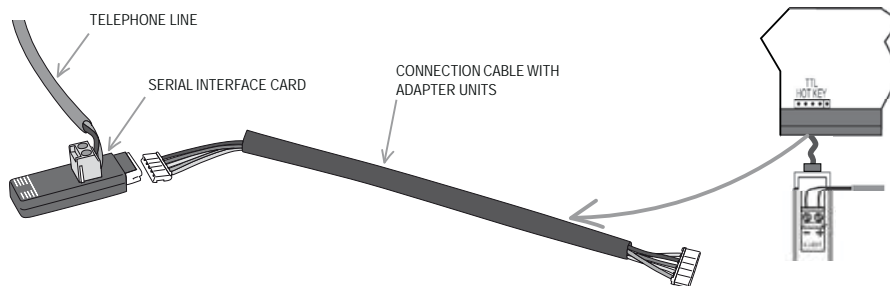

4.14 Filter extraction

Remove the front panels and extract the filters as shown in the image below

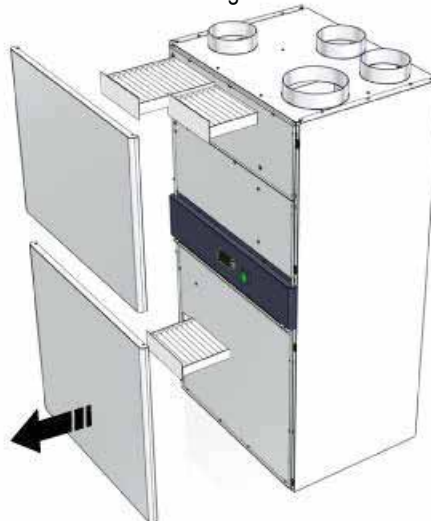

The filtering material can be reused by blowing or aspiration with air. Due to its high efficiency, the filter material can be regenerated no more than three or four times, after which it will be necessary to replace the filter itself.

4.15 Heat recovery extraction

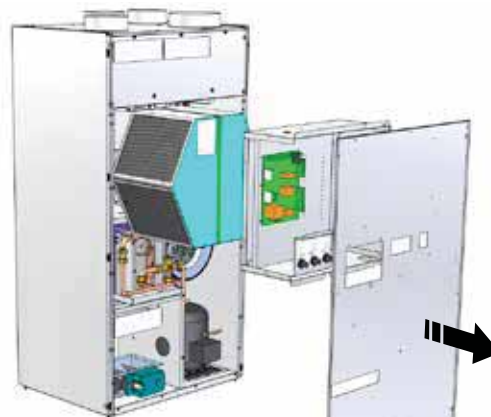

Remove the heat recovery as shown in the picture. Never use water to clean the heat recovery. Only use a vacuum cleaner to avoid damages on the fins.

4.16 Electric connections: preliminary safety information

The electric panel is located inside the unit at the top of the technical compartment where the various components of the refrigerant circuit are also to be found. To access the electrical board, remove the front panel of the unit:



Power connections must be made in accordance to the wiring diagram enclosed with the unit and in accordance to the norms in force.



Make sure the power supply upstream of the unit is (blocked with a switch). Check that the main switch handle is padlocked and it is applied on the handle a visible sign of warning not to operate.



It must be verified that electric supply is corresponding to the unit electric nominal data (tension, phases, frequency) reported on the label in the front panel of the unit.



Power cable and line protection must be sized according to the specification reported on the form of the wiring diagram enclosed with the unit.



The cable section must be commensurate with the calibration of the system-side protection and must take into account all the factors that may influence (temperature, type of insulation, length, etc.).



Power supply must respect the reported tolerances and limits: If those tolerances should not be respected, the warranty will be invalidated.



Make all connections to ground provided by law and legislation.



Before any service operation on the unit, be sure that the electric supply is disconnected.



FROST PROTECTION

If opened, the main switch cuts the power off to any electric heater and antifreeze device supplied with the unit, including the compressor crankcase heaters. The main switch should only be disconnected for cleaning, maintenance or unit repair.

4.17 Electrical data



The electrical data reported below refer to the standard unit without accessories. In all other cases refer to the data reported in the attached electrical wiring diagrams.



The line voltage fluctuations can not be more than $\pm 10\%$ of the nominal value, while the voltage unbalance between one phase and another can not exceed 1%, according to EN60204. If those tolerances should not be respected, please contact our Company.

Model		26
Power supply	V/-/Hz	230/1/50
Control board	V/-/Hz	24 V
Auxiliary circuit	V/-/Hz	230/1/50
Fans power supply	V/-/Hz	230/1/50
Line section	mm ²	1,5
PE section	mm ²	1,5



Electric data may change for updating without notice. It is therefore necessary to refer always to the wiring diagram present in the units.

4.19 Electric connections



The numbering of the terminals may change without notice. For their connection is mandatory to refer to the wiring diagram supplied along with the unit.

All terminals shown below are present in the terminal board inside the electrical box. All electric connections have to be made by the installer, in site.

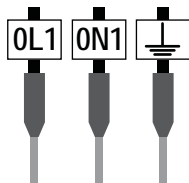

UNIT POWER SUPPLY

Units are supplied with voltage 230/1/50; it is recommended to interpose a main switch on the power line. Please refer to the wiring diagram for the correct sizing.

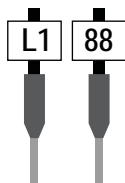

REMOTE SUMMER / WINTER CHANGE OVER

To remotely switch the unit from heating to cooling. Connections must be potential-free. The units are supplied with bridged terminals. Contact closed, unit in WINTER mode, Contact open, unit SUMMER mode.

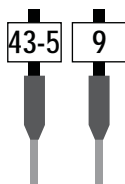

REMOTE ON / OFF

To switch the unit on or off remotely. Connections must be potential-free. The units are supplied with bridged terminals. Contact closed, unit ON, Contact open, unit OFF.

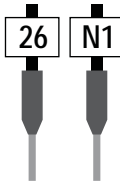
**HOT WATER PUMP**

To be connected to terminals 26 and N1; with maximum absorption of current of 1A. In the case of higher input current an appropriate relay must be used. In the standard configuration the microprocessor turns off the water pump when the set point is reached. This solution allows an important reduction of electric power consumption when the set point is reached or when the unit is in standby.

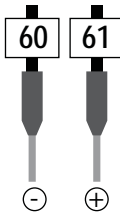
**REMOTE CONTROL PANEL**

The remote control panel replicates all of the functions on the main controller panel and can be connected up to a maximum distance of 50 meters from the unit. The panel has to be connected to the unit by 2 wires having diameter 0.75 mm². The power supply cables must be separated from the remote control panel wires, in order to avoid interference. The control panel has to be connected to the terminals 60 - and 61 + . The control panel cannot be installed in an area subject to excessive vibration, corrosive gases, is a dirty environment or has a high humidity level. The ventilation openings must not be blocked.

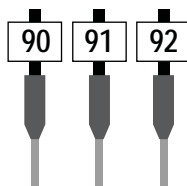
**REMOTE GENERAL ALARM**

For remote display of a general alarm, connect the visual or audible device between terminals 90-91-92.

Contacts 90/91 NC (Normally closed)
 Contacts 91/92 NO (Normally opened)

5. UNIT START UP**5.1 Preliminary checks**

Before starting the unit the checks detailed in this manual of the electric supply and connections, the hydraulic system and the refrigerant circuit, should be performed.



Start-up operations must be performed in accordance with the instructions detailed in the previous paragraphs.

5.1.1 Before start-up

Damage can occur during shipment or installation. It is recommended that a detailed check is made, before the installation of the unit, for possible refrigerant leakages caused by breakage of capillaries, pressure switch connections, tampering of the refrigerant pipework, vibration during transport or general abuse suffered by the unit.

- Verify that the unit is installed in a workmanlike manner and in accordance with the guidelines in this manual.
- Check that all power cables are properly connected and all terminals are correctly fixed.
- VThe operating voltage between phases R S T is the one shown on the unit labels.
- Check that the unit is connected to the system earth.
- Check that there is no refrigerant leakage.
- Check for oil stains, sign of a possible leak.
- Check that the refrigerant circuit shows the correct standing pressure on the pressure gauges (if present) otherwise use external ones.
- Check that the Shrader port caps are the correct type and are tightly closed.
- Check that all water connections are properly installed and all indications on unit labels are observed.
- The system must be flushed, filled and vented in order to eliminate any air.
- Check that the water temperatures are within the operation limits reported in the manual.
- Before start up check that all panels are replaced in the proper position and locked with fastening screws.



Do not modify internal wiring of the unit as this will immediately invalidate the warranty.







5.2 Description of the control panel



5.2.1 Display icons

ICON	FUNCTION
°C °F bar PSI	Icon ON when the display show a value of temperature or pression. (°C = Celsius degrees; °F = Fahrenheit degrees; BAR = pression in Bar; PSI = pression in Psi)
🕒	Time frame between defrosts.
⚠️	Icon blinking on alarm.
menu	Function menu active.
❄️	Icon ON: Defrost cycle activated. Icon blinking: Defrost cycle timeout activated.
Flow!	Icon blinking: water flow alarm.
🔄	Circulating pump is active.
🌀	Icon ON if the fans are running.
1 2	Icon ON: the compressor is turned on Icon blinking: the compressor is in the ignition timing.
⚡	Icon ON if the Vf, Pf and Vfa outputs are active.
❄️ ☀️	Icon ON if the unit is turned ON and show the working mode of the unit: Cooling or heating.
HP	Icon HP and LP blinking if high pressure or low pressure alarms are active.

5.2.2 Keys function

KEY	FUNCTION
	M Press and release: makes it possible to enter the functions menu.
	<p>SET Press and release in the main display: makes it possible to display the set points; Summer humidity set, in the bottom line will appear the label SETU. Winter humidity set, in the bottom line will appear the label SETI. Summer temperature set, in the bottom line will appear the label SETC. Winter temperature set, in the bottom line will appear the label SETH</p> <p>Press for 3 seconds and release in the main display: makes it possible to modify the set points;</p>
	<p>Allows the display of the temperatures</p> <p>1 click: The bottom line displays tbfr: Heat recovery inlet temperature 2 clicks: The bottom line displays Tamb: Ambient temperature 3 clicks: The bottom line displays tpre: temperature after water coil 4 clicks: The bottom line displays rH: ambient humidity</p> <p>In programming mode it allows the user to scroll through parameter codes or to change values.</p>
	<p>In standard mode allows the display of the different temperatures in opposite way of the above arrow. In programming mode allows to scroll through the parameter codes or increases the values.</p>
	If pressed for 5 seconds, it makes it possible to switch the unit on or off in summer mode.
	If pressed for 5 seconds, it makes it possible to switch the unit on or off in winter mode.

If the unit is in OFF or in stand-by mode, all the set-points will be shown by pressing repeatedly the SET key. When the unit is ON in a specific operation mode, it will be possible to read only the set points related to it.

5.3 Remote control panel



5.3.1 Installation

The remote control panel is mounted on a panel with 72x56 mm cut-out, fixed with screw.

To obtain IP65 protection for the panel, use the rubber gasket RGW-V (optional). For wall mounting use the V-KIT plastic adapter as illustrated in the picture.

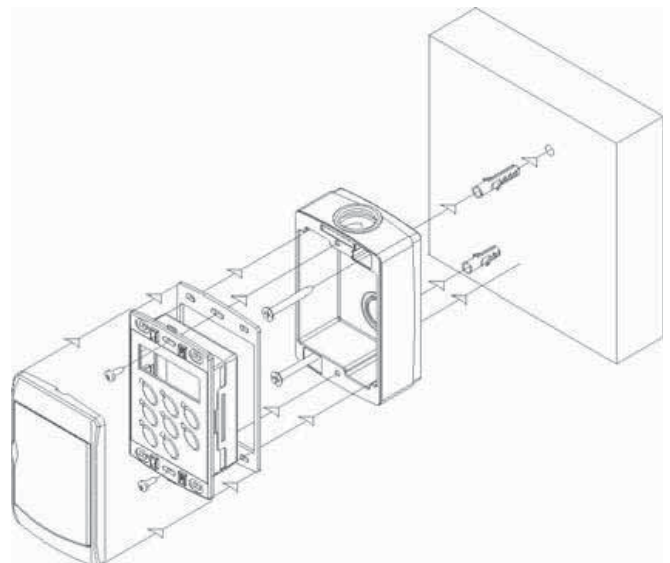
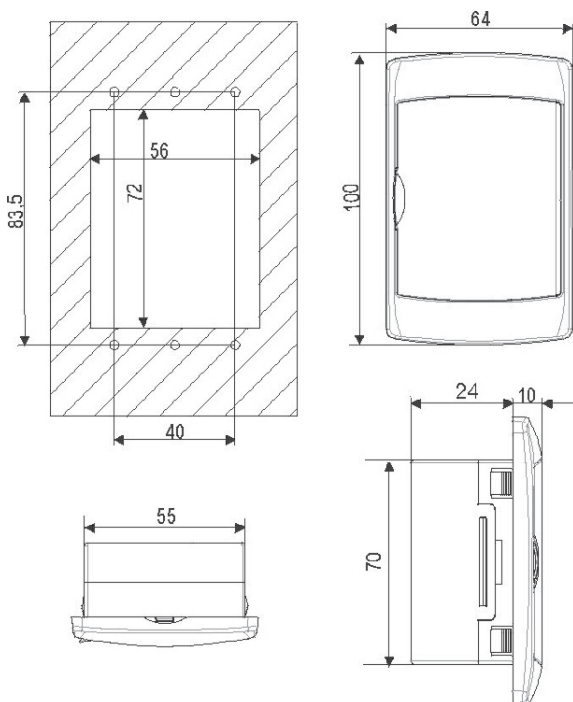

Electric data can be updated without notice. It is therefore necessary to always refer to the wiring diagram provided in the unit.



If there is damage to the remote control or there is a faulty connection, failure of communication will be indicated in the display with the message "noL" (no link).

5.3.2 Display icons

ICON	FUNCTION
	Icon ON when the display show a value of temperature or pression. (°C = Celsius degrees; °F = Fahrenheit degrees; BAR = pression in Bar; PSI = pression in Psi)
	Time frame between defrosts.
	Icon blinking on alarm.
menu	Function menu active.
	Icon ON: Defrost cycle activated. Icon blinking: Defrost cycle timeout activated.
Flow!	Icon blinking: water flow alarm.
	Circulating pump is active.
	Icon ON if the fans are running.
	Icon ON: the compressor is turned on Icon blinking: the compressor is in the ignition timing.
	Icon ON if the Vf, Pf and Vfa outputs are active.
	Icon ON if the unit is turned ON and show the working mode of the unit: Cooling or heating.
HP	Icon HP and LP blinking if high pressure or low pressure alarms are active.

5.2.2 Key function

KEY	FUNCTION
	M Press and release: makes it possible to enter the functions menu.
	SET Press and release in the main display: makes it possible to display the set points; Summer humidity set, in the bottom line will appear the label SETU. Winter humidity set, in the bottom line will appear the label SETI. Summer temperature set, in the bottom line will appear the label SETC. Winter temperature set, in the bottom line will appear the label SETH Press for 3 seconds and release in the main display: makes it possible to modify the set points;
	Allows the display of the temperatures 1 click: The bottom line displays tbfr : Heat recovery inlet temperature 2 clicks: The bottom line displays Tamb : Ambient temperature 3 clicks: The bottom line displays tpre : temperature after water coil 4 clicks: The bottom line displays rH : ambient humidity In programming mode it allows the user to scroll through parameter codes or to change values.
	In standard mode allows the display of the different temperatures in opposite way of the above arrow. In programming mode allows to scroll through the parameter codes or increases the values.
	If pressed for 5 seconds, it makes it possible to switch the unit on or off in summer mode.
	If pressed for 5 seconds, it makes it possible to switch the unit on or off in winter mode.

If the unit is in OFF or in stand-by mode, all the set-points will be shown by pressing repeatedly the SET key. When the unit is ON in a specific operation mode, it will be possible to read only the set points related to it.

6. USE





6.1 Switch the unit on

In order to power the unit, turn the main switch to the ON position.





The display shows the ambient temperature (top) and ambient humidity (bottom).



6.1.1 Summer mode

Press the  key for 5 seconds, the unit turn on in summer mode; the icon blinking, after few seconds the  (fan) and  (pump) icons will be activated. After few minutes the  icon will be is ON and the compressor will be activated.

6.1.2 Winter mode

Press the  key for 5 seconds, the unit turn on in winter mode; the icon blinking, after few seconds the  (fan) and  (pump) icons will be activated. After few minutes the  icon will be is ON and the compressor will be activated.

6.2 Stop

6.2.1 Summer mode

To stop the unit in heating mode, press the key . The LED switches off. The unit goes into stand-by mode.

6.2.2 Winter mode

To stop the unit in heating mode, press the key . The LED switches off. The unit goes into stand-by mode.

6.3 Stand-by

When the unit is switched off from the keyboard or the remote panel, it goes into standby mode. In this mode, the microprocessor control displays the sensor readings and is also able to manage alarm situations. The only visible signal on the display is the green led of circuit1 and the temperatures. If the unit is switched off from remote ON/OFF the label OFF is displayed.

Stand-by display



In stand-by mode, the display shows the label OFF only if the remote ON/OFF potential-free contact is open.

6.4 How to change the set points



When modifying or varying the machine's operating parameters, make sure that you do not create situations that conflict with the other set parameters.



The complete display of the 3 set points (heating, domestic hot water, cooling) is ONLY available when the unit is in stand-by mode. It is suggested to put the unit in stand by when modifying set points. If the unit is not in stand-by, the only editable parameters are the ones related to the operation mode of the unit (eg. In heating mode it is only possible to change the heating and domestic hot water set points, in cooling mode it is only possible to change the cooling and domestic hot water set points.)



Select the required set point using the **SET** key. The following label appears at the bottom of the display:

- SEtU** Summer humidity set point;
- SEtI** Winter humidity set point;
- SEtC** Summer temperature set point;
- SEtH** Winter humidity set point.

To set the required set-points press again the **SET** key for 3 seconds. the current value blinking and can be modified using the **▲** , **▼** keys to set the new value. Then press the **SET** key to save the parameter and exit the menu.



All set points refer to the ambient air recovery conditions.

6.4.1 Adjustable parameters

The adjustable set points that can be modified by the end user are:

Label	Function	Adjustment limit	Default value
SEt U	Summer humidity set point	40÷80%	60%
SEt I	Winter humidity set point	40÷90%	50%
SEt C	Summer temperature set point	18÷30°C	26°C
SEt H	Winter temperature set point	18÷25°C	22°C
PAS	Password	(Contact the Company)	



The units are supplied with a very sophisticated control system with many other parameters that are not adjustable by the end user; these parameters are protected by a manufacturer password.



6.5 Acoustic signal silencing

Pressing and releasing one of the keys; the buzzer is switched off, even if the alarm condition remains in place.

6.6 Displaying during an alarm







alarm code in the bottom line:

- HP +  + alarm code in the bottom line*: high pressure alarm
-  + alarm code in the bottom line*

* the bottom side of the display shows alternately the alarm code and the normal visualization.

LP, HP, FLOW and  icons, are blinking in presence of an alarm.

6.7 Alarm reset

Press the  key (the menu AlrM appears at the bottom right of the display). Press the  key to display the alarm event. In case of multiple alarms use the using the  ,  keys, to scroll through the list of the active alarms.

There are two types of alarms:

Reset alarms:

RST label appears on the upper part of the display. In this case press the  key to reset.

Non reset alarms:

nO label appears on the upper part of the display. In this case the alarm is permanent; contact the company service.

7. MANUTENZIONE UNITÀ

7.1 General warnings

Maintenance can:

- Keep the equipment operating efficiently
- Prevent failures
- Increase the equipment life



It is advisable to maintain a record book for the unit which details all operations performed on the unit as this will facilitate troubleshooting.



Maintenance must be performed in compliance with all requirements of the previous paragraphs.



Use personal protective equipment required by regulations as compressor casings and discharge pipes are at high temperatures. Coil fins are sharp and present a cutting hazard.

7.2 Drive access

Access to the unit once installed, should only be possible to authorized operators and technicians. The owner of the equipment is the company legal representative, entity or person owns the property where the machine is installed. They are fully responsible for all safety rules given in this manual and regulations.

7.3 Periodical checks



The start-up operations should be performed in compliance with all requirements of the previous paragraphs.



All of the operations described in this chapter **MUST BE PERFORMED BY TRAINED PERSONNEL ONLY**. Before commencing service work on the unit ensure that the electric supply is disconnected. The top case and discharge line of compressor are usually at high temperature. Care must be taken when working in their surroundings. Aluminium coil fins are very sharp and can cause serious wounds. Care must be taken when working in their surroundings. After servicing, replace the cover panels, fixing them with locking screws.

7.3.1 Every 6 months:

It is advisable to perform periodic checks in order to verify the correct working of the unit. Check that safety and control devices work correctly as previously described.

- Check all the terminals on the electric board and on the compressor are properly fixed.
- Check and clean the sliding terminals of the contactors.
- Check for water leaks in the hydraulic system.
- Check correct operation of the flow switch and clean the strainers on the pipework.
- Check the compressor crankcase heater has the proper supply and is functioning correctly.
- Check the state of the finned coil, removing any debris or leaves. If possible, use compressed air to blow through in the opposite direction to the airflow. If the coil is heavily clogged, clean it with a low pressure washer, taking care to avoid damaging the aluminium fins.
- Check mounting of fan blades and their balancing.

7.3.2 End of seasons or unit switched off:

If the unit is to be left out of commission for a long period, the hydraulic circuit should be drained down. This operation is compulsory if the ambient temperature is expected to drop below the freezing point of the fluid in the circuit (water or Glycol mix).

7.4 Refrigerant circuit repair



If the refrigerant circuit is to be emptied, all the refrigerant must be recovered using the correct equipment.

For leak detection, the system should be charged with nitrogen using a gas bottle with a pressure reducing valve, until 15 bar pressure is reached. Any leakage is detected using a bubble leak finder. If bubbles appear discharge the nitrogen from the circuit before brazing using the proper alloys.



Never use oxygen instead of nitrogen: explosions may occur.

Site assembled refrigerant circuits must be assembled and maintained carefully, in order to prevent malfunctions.

Therefore:

- Avoid oil replenishment with products that are different from that specified and that are pre-loaded into the compressor.
- In the event of a gas leakage on machines using refrigerant R134A, R410A even if it is only a partial leak, do not top up. The entire charge must be recovered, the leak repaired and a new refrigerant charge weighed in to the circuit.
- When replacing any part of the refrigerant circuit, do not leave it exposed for more than 15 minutes.
- It is important when replacing a compressor that the task be completed within the time specified above after removing the rubber sealing caps.
- When replacing the compressor following a burn out, it is advisable to wash the cooling system with appropriate products including a filter for acid.
- When under vacuum do not switch on the compressor.

8. DECOMMISSIONING

8.1 Disconnect the unit



All decommissioning operations must be performed by authorized personnel in accordance with the national legislation in force in the country where the unit is located.

- Avoid spills or leaks into the environment.
- Before disconnecting the machine please recover:
 - the refrigerant gas;
 - Glycol mixture in the hydraulic circuit;
 - the compressor lubricating oil.

Before decommissioning the machine can be stored outdoors, providing that it has the electrical box, refrigerant circuit and hydraulic circuit intact and closed.

8.2 Disposal, recovery and recycling

The frame and components, if unusable, should be taken apart and sorted by type, especially copper and aluminum that are present in large quantities in the machine.

All materials must be recovered or disposed in accordance with national regulations.

8.3 RAEE Directive (only UE)



The crossed-out bin symbol on the label indicates that the product complies with regulations on waste electrical and electronic equipment. The abandonment of the equipment in the environment or its illegal disposal is punishable by law.

This product is included in the application of Directive 2012/19/EU on the management of waste electrical and electronic equipment (WEEE).

The unit should not be treated with household waste as it is made of different materials that can be recycled at the appropriate facilities. Inform through the municipal authority about the location of the ecological platforms that can receive the product for disposal and its subsequent proper recycling.

The product is not potentially dangerous for human health and the environment, as it does not contain dangerous substances as per Directive 2011/65/EU (RoHS), but if abandoned in the environment it has a negative impact on the ecosystem.

Read the instructions carefully before using the unit for the first time. It is recommended not to use the product for any purpose other than that for which it was designed, as there is a risk of electric shock if used improperly.

9. DIAGNOSIS AND TROUBLESHOOTING

9.1 Fault finding

All units are checked and tested at the factory before shipment, however, during operation an anomaly or failure can occur.



BE SURE TO RESET AN ALARM ONLY AFTER YOU HAVE REMOVED THE CAUSE OF THE FAULT; REPEATED RESET MAY RESULT IN IRREVOCABLE DAMAGE TO THE UNIT.

Code	Alarm description	Cause	Solution
AhiP	High pressure alarm	Insufficient water flow	Verificare totale assenza di aria nel circuito idraulico ed eventuale spurgo della stessa. Verifica della portata d'acqua all'unità (vedere catalogo tecnico).
APBa	Room sensor temperature error PBa	Damaged sensor	Contact the service department
APBr	Pre-treatment sensor error PBr		
APbf	Antifreeze sensor error PBf		
APBu	Room sensor humidity error PBu		
APBc	Antifreeze sensor error PBc		
AtFr	Antifreeze alarm PBFr	Alarm of exceeded temperature/pressure threshold	Only warning; the unit restore automatically its operation mode.
AtMr	Too high fresh air temperature PBFr		
AFL	Flussostato	Insufficient water flow	Check the water flow to the unit (see technical catalog).
Atdf	Defrost ended by maximum defrost time	Defrost time too long	Only warning; the unit restore automatically its operation mode.

10. DIMENSIONAL DRAWINGS

FHE 26

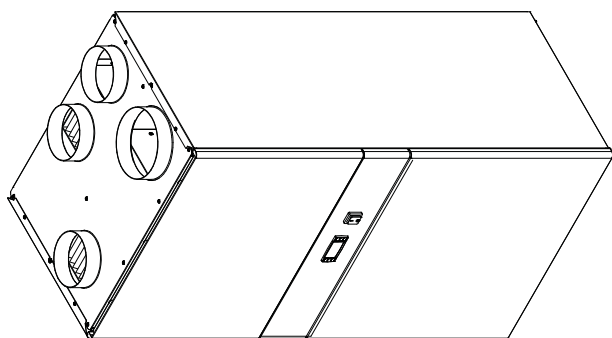
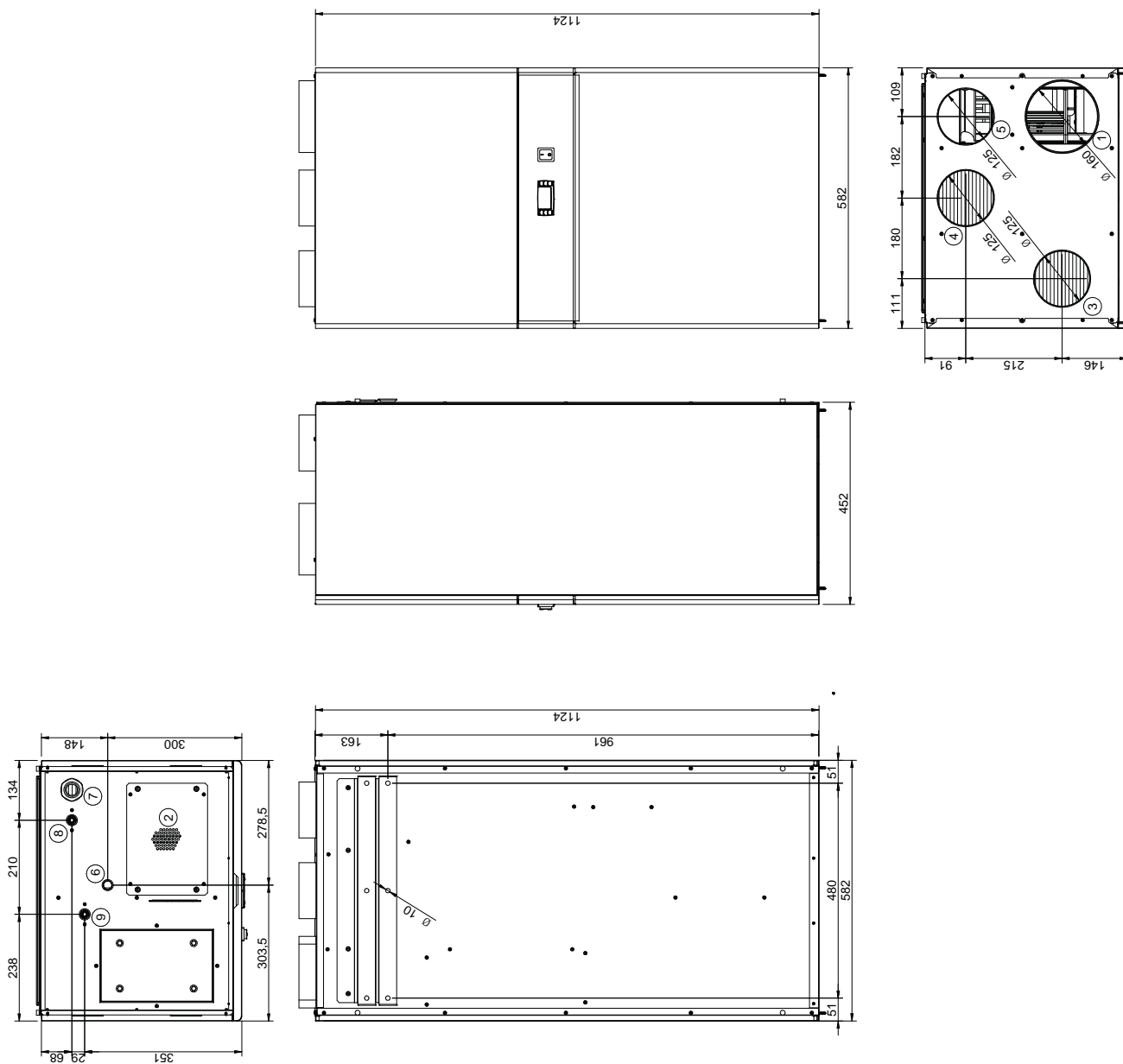

1	ARIA DI MANDATA
2	ARIA DI RIPRESA
3	ARIA DI RIPRESA WC
4	ARIA ESTERNA
5	ARIA ESPULSA
6	SCARICO CONDENSA Ø 20
7	INGRESSO ALIMENTAZIONE ELETTRICA
8	USCITA ACQUA Ø 1/2" GM
9	INGRESSO ACQUA Ø 1/2" GM
10	SPAZIO PER ESTRAZIONE FILTRI



HIDROS Srl

Sede legale: Via A. Volta, 49 ▪ cap 47014 ▪ Meldola (FC)
Sede operativa: Via E.Mattei, 20 ▪ cap 35028 ▪ Piove di Sacco (Pd) Italy
Tel. +39 049 9731022 ▪ Fax +39 049 5806928
Info@hidros.it ▪ www.hidros.it

P.IVA e C.F 04297230403 ▪ R.E.A. FO 337725

Technical data shown in this booklet are not binding.

The Company shall have the right to introduce at any time whatever modifications necessary to the improvement of the product.
The reference languages for the whole documentation are Italian and English. The other languages are to be considered only as guidelines.
