

LZT/P4

4 pipe systems High efficiency air to water heat pumps with E.V.I. compressors

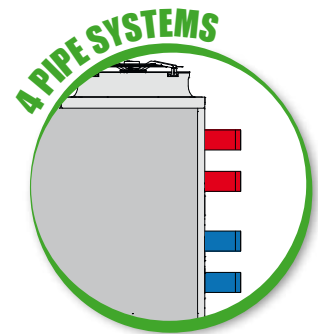

- CE
- R410A
- 20°C
- +43°C
- +65°C
- EVI
- E.C.
- FLOATING FRAME
- ZZ

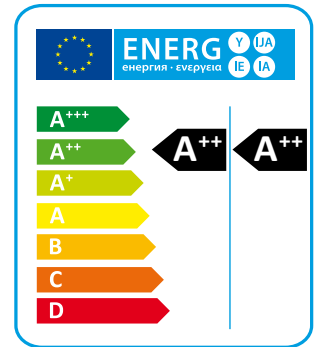

The high efficiency air / water heat pumps of the LZT/P4 series are units designed for 4-pipe air conditioning and heating systems, which allow the production of cold water for cooling and hot water for heating at the same time or separately. The units are supplied with an additional exchanger, used as a condenser for hot water, the production of which is independent of the operation mode of the unit. Activation of the exchanger takes place automatically via the microprocessor control when the hot water temperature on the return is lower than the set point. These units are able to produce hot water and cold water simultaneously and / or separately with very high energy efficiencies. They are all supplied complete with a specific advanced microprocessor control provided with software for managing the various priorities. The XL versions also have an extremely low noise level thanks to the use of a special floating vibration damping system that allows a noise reduction of about 6-8 dB (A) (optional).

Versions

- P4U** 4 pipe systems heating/cooling.
- P4S** 2+2 pipe systems with D.H.W. production.
- SA** Standard efficiency, AC fans.
- SE** Standard efficiency, EC fans.
- HA** High efficiency, AC fans.
- HE** High efficiency, EC fans.
- LS** Low noise.
- XL** Super low noise.
- NN** Ultra low noise.

SA/LS/RV - P4U/P4S		242	292	432	492	592	752	852
Heating capacity (EN14511) ⁽¹⁾	kW	23,7	28,3	42,1	50,9	55,0	67,8	74,5
Total input power (EN14511) ⁽¹⁾	kW	5,5	6,8	10,3	12,3	13,4	16,3	18,3
COP (EN14511) ⁽¹⁾	W/W	4,31	4,16	4,11	4,14	4,12	4,16	4,07
Energy Class in low temperature ⁽²⁾		A+	A+	A+	A+	A+	A+	A+
SCOP low temperature ⁽²⁾	kWh/kWh	3,75	3,77	3,39	3,33	3,49	3,70	3,62
η _{s,h} low temperature ⁽²⁾	%	147	148	133	130	137	145	142
Energy Class in medium temperature ⁽²⁾		A+	A+	A+	A+	A+	A+	A+
SCOP medium temperature ⁽²⁾	kWh/kWh	3,04	3,07	2,89	2,87	2,93	3,06	3,03
η _{s,h} medium temperature ⁽²⁾	%	119	120	112	112	114	119	118
Cooling capacity (EN14511) ⁽³⁾	kW	22,5	29,5	36,4	46,1	53,6	61,6	74,3
Total input power (EN14511) ⁽³⁾	kW	7,1	9,1	12,9	16,4	19,3	22,3	25,5
EER (EN14511) ⁽³⁾	W/W	3,15	3,24	2,82	2,80	2,78	2,76	2,91
Sound power ⁽⁴⁾	dB (A)	78	78	79	80	80	80	80
Sound pressure ⁽⁵⁾	dB (A)	46	46	47	48	48	48	48
SE/LS/RV - P4U/P4S		242	292	432	492	592	752	852
Heating capacity (EN14511) ⁽¹⁾	kW	23,7	28,3	42,1	50,5	55,2	67,8	74,7
Total input power (EN14511) ⁽¹⁾	kW	5,3	6,7	9,9	12,8	13,8	16,1	18,2
COP (EN14511) ⁽¹⁾	W/W	4,47	4,22	4,25	3,95	4,00	4,21	4,10
Energy Class in low temperature ⁽²⁾		A++	A++	A+	A+	A+	A+	A+
SCOP low temperature ⁽²⁾	kWh/kWh	3,95	3,87	3,58	3,45	3,59	3,79	3,68
η _{s,h} low temperature ⁽²⁾	%	155	152	140	135	141	149	144
Energy Class in medium temperature ⁽²⁾		A+	A+	A+	A+	A+	A+	A+
SCOP medium temperature ⁽²⁾	kWh/kWh	3,17	3,13	3,02	2,99	3,02	3,13	3,10
η _{s,h} medium temperature ⁽²⁾	%	124	122	118	116	118	122	121
Cooling capacity (EN14511) ⁽³⁾	kW	22,65	29,92	36,5	46,43	53,75	61,94	74,64
Total input power (EN14511) ⁽³⁾	kW	7,1	9,0	12,8	16,2	19,2	21,9	25,4
EER (EN14511) ⁽³⁾	W/W	3,19	3,32	2,86	2,86	2,81	2,83	2,94
Sound power ⁽⁴⁾	dB (A)	82	82	83	84	84	83	84
Sound pressure ⁽⁵⁾	dB (A)	50	50	51	52	52	51	52
Power supply	V/Ph/Hz	400/3+N/50	400/3+N/50	400/3/50	400/3/50	400/3/50	400/3/50	400/3/50
Compressors / Circuits	n° / n°	2 / 1	2 / 1	2 / 1	2 / 1	2 / 1	2 / 1	2 / 1
Fans	n°	1	1	2	2	2	2	2
Refrigerant		R410A	R410A	R410A	R410A	R410A	R410A	R410A
Refrigerant charge	kg	10,0	10,0	10,0	12,0	12,0	18,0	19,0
Global warming potential (GWP)		2088	2088	2088	2088	2088	2088	2088
Equivalent CO ₂ charge	t	20,88	20,88	20,88	25,05	25,05	37,58	39,67
Water tank volume	l	100	100	100	100	100	300	300
SA/LS/RV - P4U/P4S		1002	1202	1454	1654	1854	2154	
Heating capacity (EN14511) ⁽¹⁾	kW	88,5	102,5	145,3	162,9	180,2	205,4	
Total input power (EN14511) ⁽¹⁾	kW	21,1	25,8	35,2	41,2	43,6	52,9	
COP (EN14511) ⁽¹⁾	W/W	4,21	3,98	4,13	3,96	4,13	3,88	
Energy Class in low temperature ⁽²⁾		A+	A+	A+	A+	A+	A+	
SCOP low temperature ⁽²⁾	kWh/kWh	3,61	3,60	3,44	3,42	3,43	3,42	
η _{s,h} low temperature ⁽²⁾	%	141	141	135	134	134	134	
Energy Class in medium temperature ⁽²⁾		A+	A+	A+	A+	A+	A+	
SCOP medium temperature ⁽²⁾	kWh/kWh	3,01	2,99	2,85	2,90	2,92	2,95	
η _{s,h} medium temperature ⁽²⁾	%	117	117	111	113	114	115	
Cooling capacity (EN14511) ⁽³⁾	kW	77,9	90,4	125,8	142,0	155,1	177,9	
Total input power (EN14511) ⁽³⁾	kW	26,9	32,6	44,1	51,7	55,3	68,6	
EER (EN14511) ⁽³⁾	W/W	2,89	2,77	2,85	2,75	2,80	2,59	
Sound power ⁽⁴⁾	dB (A)	80	80	87	87	88	89	
Sound pressure ⁽⁵⁾	dB (A)	48	48	55	55	56	57	
SE/LS/RV - P4U/P4S		1002	1202	1454	1654	1854	2154	
Heating capacity (EN14511) ⁽¹⁾	kW	88,2	102,5	146,0	164,3	181,3	208,1	
Total input power (EN14511) ⁽¹⁾	kW	20,7	25,4	33,6	39,03	41,91	50,66	
COP (EN14511) ⁽¹⁾	W/W	4,26	4,03	4,35	4,21	4,33	4,11	
Energy Class in low temperature ⁽²⁾		A+	A+	A+	A+	A+	A+	
SCOP low temperature ⁽²⁾	kWh/kWh	3,69	3,70	3,63	3,57	3,69	3,63	
η _{s,h} low temperature ⁽²⁾	%	145	145	142	140	145	142	
Energy Class in medium temperature ⁽²⁾		A+	A+	A+	A+	A+	A+	
SCOP medium temperature ⁽²⁾	kWh/kWh	3,10	3,06	2,95	2,99	3,06	3,07	
η _{s,h} medium temperature ⁽²⁾	%	121	120	115	117	120	120	
Cooling capacity (EN14511) ⁽³⁾	kW	78,1	90,9	126,4	143,1	156,3	179,3	
Total input power (EN14511) ⁽³⁾	kW	25,0	32,1	41,7	49,5	53,5	66,1	
EER (EN14511) ⁽³⁾	W/W	3,13	2,83	3,03	2,89	2,92	2,71	
Sound power ⁽⁴⁾	dB (A)	84	84	85	85	86	86	
Sound pressure ⁽⁵⁾	dB (A)	52	52	53	53	54	54	
Power supply	V/Ph/Hz	400/3/50	400/3/50	400/3/50	400/3/50	400/3/50	400/3/50	
Compressors / Circuits	n° / n°	2 / 1	2 / 1	4/2	4/2	4/2	4/2	
Fans	n°	3	4	4	4	4	4	
Refrigerant		R410A	R410A	R410A	R410A	R410A	R410A	
Refrigerant charge	kg	23,0	23,0	45,0	45,0	50,0	50,0	
Global warming potential (GWP)		2088	2088	2088	2088	2088	2088	
Equivalent CO ₂ charge	t	48,02	48,02	93,96	93,96	104,40	104,40	
Water tank volume	l	300	300	500	500	500	500	

Performances are referred to the following conditions:

- (1) Heating: Ambient temperature 7°C DB, 6°C WB, water temperature 30/35°C.
(2) Average conditions, variable - Reg EU 811/2013

(3) Cooling: ambient air temperature 35°C, evaporator water temperature in/out 12/7 °C..

(4) Sound power level in accordance with ISO 3744..

(5) Sound pressure level at 10 mt from the unit in free field conditions in accordance with ISO 3744.

HA/LS/RV - P4U/P4S		242	292	432	492	602	752	852
Heating capacity (EN14511) ⁽¹⁾	kW	23,8	29,4	41,6	51,2	58,0	66,7	80,8
Total input power (EN14511) ⁽¹⁾	kW	5,3	6,8	9,7	12,4	13,0	15,6	19,6
COP (EN14511) ⁽¹⁾	W/W	4,51	4,31	4,29	4,12	4,45	4,29	4,13
Energy Class in low temperature ⁽²⁾		A++	A++	A+	A+	A++	A++	A+
SCOP low temperature ⁽²⁾	kWh/kWh	3,96	3,89	3,63	3,55	3,94	3,95	3,76
η _{s,h} low temperature ⁽²⁾	%	155	153	142	139	155	155	147
Energy Class in medium temperature ⁽²⁾		A+	A+	A+	A+	A++	A+	A+
SCOP medium temperature ⁽²⁾	kWh/kWh	3,18	3,15	2,99	2,98	3,21	3,16	3,01
η _{s,h} medium temperature ⁽²⁾	%	124	123	117	116	126	123	117
Cooling capacity (EN14511) ⁽³⁾	kW	22,9	30,1	37,5	46,7	52,8	62,5	71,6
Total input power (EN14511) ⁽³⁾	kW	7,0	9,0	12,7	16,1	18,1	21,6	24,6
EER (EN14511) ⁽³⁾	W/W	3,25	3,36	2,97	2,90	2,91	2,89	2,91
Sound power ⁽⁴⁾	dB (A)	78	78	78	79	80	80	83
Sound pressure ⁽⁵⁾	dB (A)	46	46	46	47	48	48	51
HE/LS/RV - P4U/P4S		242	292	432	492	602	752	852
Heating capacity (EN14511) ⁽¹⁾	kW	24,0	29,5	41,8	50,3	58,3	66,9	81,3
Total input power (EN14511) ⁽¹⁾	kW	5,2	6,7	9,5	12,2	12,8	15,3	18,9
COP (EN14511) ⁽¹⁾	W/W	4,61	4,38	4,40	4,12	4,56	4,37	4,31
Energy Class in low temperature ⁽²⁾		A++	A++	A++	A++	A++	A++	A++
SCOP low temperature ⁽²⁾	kWh/kWh	4,10	3,96	3,87	3,83	4,08	4,06	3,83
η _{s,h} low temperature ⁽²⁾	%	161	156	152	150	160	159	150
Energy Class in medium temperature ⁽²⁾		A++	A++	A+	A+	A++	A++	A+
SCOP medium temperature ⁽²⁾	kWh/kWh	3,25	3,21	3,12	3,15	3,29	3,23	3,07
η _{s,h} medium temperature ⁽²⁾	%	127	125	122	123	129	126	120
Cooling capacity (EN14511) ⁽³⁾	kW	22,9	30,2	37,5	45,6	52,9	62,5	71,6
Total input power (EN14511) ⁽³⁾	kW	7,0	8,8	12,7	16,7	17,9	21,3	24,4
EER (EN14511) ⁽³⁾	W/W	3,27	3,42	2,96	2,73	2,95	2,64	2,94
Sound power ⁽⁴⁾	dB (A)	82	82	80	81	83	83	86
Sound pressure ⁽⁵⁾	dB (A)	50	50	48	49	51	51	54
Power supply	V/Ph/Hz	400/3+N/50	400/3+N/50	400/3/50	400/3/50	400/3/50	400/3/50	400/3/50
Compressors / Circuits	n° / n°	2 / 1	2 / 1	2 / 1	2 / 1	2 / 1	2 / 1	2 / 1
Fans	n°	1	1	2	2	2	2	2
Refrigerant		R410A	R410A	R410A	R410A	R410A	R410A	R410A
Refrigerant charge	kg	10,0	10,0	14,5	12,0	18,0	23,0	23,0
Global warming potential (GWP)		2088	2088	2088	2088	2088	2088	2088
Equivalent CO ₂ charge	t	20,88	20,88	30,27	25,05	37,58	48,02	48,02
Water tank volume	l	100	100	100	100	300	300	300
HA/LS/RV - P4U/P4S		1002	1202	1454	1654	1854	2154	
Heating capacity (EN14511) ⁽¹⁾	kW	88,4	102,5	145,6	163,7	181,9	210,2	
Total input power (EN14511) ⁽¹⁾	kW	21,4	25,3	35,2	40,7	43,8	52,2	
COP (EN14511) ⁽¹⁾	W/W	4,13	4,05	4,14	4,02	4,16	4,02	
Energy Class in low temperature ⁽²⁾		A+	A+	A+	A+	A+	A+	
SCOP low temperature ⁽²⁾	kWh/kWh	3,80	3,78	3,74	3,65	3,79	3,78	
η _{s,h} low temperature ⁽²⁾	%	149	148	147	143	149	148	
Energy Class in medium temperature ⁽²⁾		A+	A+	A+	A+	A+	A+	
SCOP medium temperature ⁽²⁾	kWh/kWh	3,05	3,06	3,05	3,03	3,12	3,16	
η _{s,h} medium temperature ⁽²⁾	%	119	120	119	118	122	123	
Cooling capacity (EN14511) ⁽³⁾	kW	78,1	90,2	127,4	143,5	157,8	180,9	
Total input power (EN14511) ⁽³⁾	kW	26,6	32,2	42,4	50,8	53,6	66,5	
EER (EN14511) ⁽³⁾	W/W	2,94	2,80	3,01	2,82	2,94	2,72	
Sound power ⁽⁴⁾	dB (A)	83	83	84	85	85	85	
Sound pressure ⁽⁵⁾	dB (A)	51	51	52	53	53	53	
HE/LS/RV - P4U/P4S		1002	1202	1454	1654	1854	2154	
Heating capacity (EN14511) ⁽¹⁾	kW	88,5	102,7	145,2	163,2	181,3	209,6	
Total input power (EN14511) ⁽¹⁾	kW	20,6	24,6	33,4	38,9	41,9	50,5	
COP (EN14511) ⁽¹⁾	W/W	4,31	4,17	4,35	4,19	4,33	4,15	
Energy Class in low temperature ⁽²⁾		A++	A++	A++	A++	A++	A++	
SCOP low temperature ⁽²⁾	kWh/kWh	3,85	3,84	3,88	3,88	3,89	3,89	
η _{s,h} low temperature ⁽²⁾	%	151	151	152	152	153	153	
Energy Class in medium temperature ⁽²⁾		A+	A+	A+	A+	A+	A+	
SCOP medium temperature ⁽²⁾	kWh/kWh	3,14	3,13	3,10	3,15	3,17	3,19	
η _{s,h} medium temperature ⁽²⁾	%	123	122	121	123	124	124	
Cooling capacity (EN14511) ⁽³⁾	kW	78,2	90,8	126,8	142,8	157,0	180,1	
Total input power (EN14511) ⁽³⁾	kW	26,1	31,3	42,0	50,5	53,4	66,2	
EER (EN14511) ⁽³⁾	W/W	3,00	2,90	3,02	2,83	2,94	2,72	
Sound power ⁽⁴⁾	dB (A)	86	86	87	88	89	88	
Sound pressure ⁽⁵⁾	dB (A)	55	55	55	56	57	56	
Power supply	V/Ph/Hz	400/3/50	400/3/50	400/3/50	400/3/50	400/3/50	400/3/50	
Compressors / Circuits	n° / n°	2 / 1	2 / 1	4/2	4/2	4/2	4/2	
Fans	n°	2	2	3	3	3	3	
Refrigerant		R410A	R410A	R410A	R410A	R410A	R410A	
Refrigerant charge	kg	27,0	27,0	45,0	45,0	50,0	50,0	
Global warming potential (GWP)		2088	2088	2088	2088	2088	2088	
Equivalent CO ₂ charge	t	56,37	56,37	93,96	93,96	104,40	104,40	
Water tank volume	l	300	300	500	500	500	500	

Performances are referred to the following conditions:

(1) Heating: Ambient temperature 7°C DB, 6°C WB, water temperature 30/35°C.

(2) Average conditions, variable - Reg EU 811/2013

(3) Cooling: ambient air temperature 35°C, evaporator water temperature in/out 12/7 °C..

(4) Sound power level in accordance with ISO 3744..

(5) Sound pressure level at 10 mt from the unit in free field conditions in accordance with ISO 3744.

HA/XL/RV - P4U/P4S		252	302	432	492	602	752	852
Heating capacity (EN14511) ⁽¹⁾	kW	24,0	29,6	41,1	48,9	57,4	65,5	80,1
Total input power (EN14511) ⁽¹⁾	kW	5,5	7,0	9,5	12,1	12,9	15,2	18,4
COP (EN14511) ⁽¹⁾	W/W	4,40	4,24	4,35	4,04	4,46	4,31	4,35
Energy Class in low temperature ⁽²⁾		A++	A++	A++	A++	A++	A++	A++
SCOP low temperature ⁽²⁾	kWh/kWh	3,83	3,84	3,84	3,83	4,03	4,01	3,83
η _{s,h} low temperature ⁽²⁾	%	150	151	151	150	158	158	150
Energy Class in medium temperature ⁽²⁾		A+	A+	A+	A+	A++	A+	A+
SCOP medium temperature ⁽²⁾	kWh/kWh	3,05	3,13	3,11	3,14	3,27	3,20	3,13
η _{s,h} medium temperature ⁽²⁾	%	119	122	121	122	128	125	122
Cooling capacity (EN14511) ⁽³⁾	kW	22,0	28,3	36,8	45,5	52,1	62,0	71,2
Total input power (EN14511) ⁽³⁾	kW	7,1	9,1	13,2	16,1	18,9	21,9	23,7
EER (EN14511) ⁽³⁾	W/W	3,10	3,13	2,78	2,82	2,75	2,83	3,00
Sound power ⁽⁴⁾	dB (A)	72	72	73	74	74	74	74
Sound pressure ⁽⁵⁾	dB (A)	40	40	41	42	42	42	42
HE/XL/RV - P4U/P4S		252	302	432	492	602	752	852
Heating capacity (EN14511) ⁽¹⁾	kW	24,0	30,0	41,2	49,2	57,4	65,6	79,9
Total input power (EN14511) ⁽¹⁾	kW	5,2	6,8	9,2	11,8	12,6	15,1	17,8
COP (EN14511) ⁽¹⁾	W/W	4,64	4,39	4,49	4,16	4,57	4,35	4,49
Energy Class in low temperature ⁽²⁾		A++	A++	A++	A++	A++	A++	A++
SCOP low temperature ⁽²⁾	kWh/kWh	4,10	3,87	4,00	3,84	4,21	4,16	4,04
η _{s,h} low temperature ⁽²⁾	%	161	152	157	151	165	163	159
Energy Class in medium temperature ⁽²⁾		A++	A+	A++	A++	A++	A++	A++
SCOP medium temperature ⁽²⁾	kWh/kWh	3,24	3,14	3,24	3,16	3,38	3,29	3,26
η _{s,h} medium temperature ⁽²⁾	%	127	123	127	123	132	129	127
Cooling capacity (EN14511) ⁽³⁾	kW	21,0	28,9	37,2	45,7	52,0	62,1	70,6
Total input power (EN14511) ⁽³⁾	kW	7,0	9,1	12,7	16,0	18,8	21,8	24,2
EER (EN14511) ⁽³⁾	W/W	2,98	3,17	2,93	2,85	2,78	2,85	2,92
Sound power ⁽⁴⁾	dB (A)	71	72	77	78	78	78	80
Sound pressure ⁽⁵⁾	dB (A)	39	40	45	46	46	46	48
Power supply	V/Ph/Hz	400/3+N/50	400/3+N/50	400/3/50	400/3/50	400/3/50	400/3/50	400/3/50
Compressors / Circuits	n° / n°	2 / 1	2 / 1	2 / 1	2 / 1	2 / 1	2 / 1	2 / 1
Fans	n°	2	2	2	2	2	2	2
Refrigerant		R410A	R410A	R410A	R410A	R410A	R410A	R410A
Refrigerant charge	kg	10,0	10,0	14,5	12,0	18,0	23,0	23,0
Global warming potential (GWP)		2088	2088	2088	2088	2088	2088	2088
Equivalent CO ₂ charge	t	20,88	20,88	30,27	25,05	37,58	48,02	48,02
Water tank volume	l	100	100	100	100	300	300	300
HA/XL/RV - P4U/P4S		1002	1202	1454	1654	1854	2154	
Heating capacity (EN14511) ⁽¹⁾	kW	87,3	100,7	147,8	166,9	187,4	218,2	
Total input power (EN14511) ⁽¹⁾	kW	20,0	23,8	33,5	38,7	43,1	51,3	
COP (EN14511) ⁽¹⁾	W/W	4,37	4,23	4,41	4,31	4,35	4,25	
Energy Class in low temperature ⁽²⁾		A++	A++	A++	A++	A++	A++	
SCOP low temperature ⁽²⁾	kWh/kWh	3,91	3,84	3,93	3,90	3,88	3,88	
η _{s,h} low temperature ⁽²⁾	%	153	151	154	153	152	152	
Energy Class in medium temperature ⁽²⁾		A++	A+	A+	A+	A+	A+	
SCOP medium temperature ⁽²⁾	kWh/kWh	3,21	3,18	3,16	3,17	3,10	3,13	
η _{s,h} medium temperature ⁽²⁾	%	126	124	123	124	121	122	
Cooling capacity (EN14511) ⁽³⁾	kW	77,1	88,7	126,6	143,4	158,7	184,3	
Total input power (EN14511) ⁽³⁾	kW	26,2	32,6	40,9	48,1	49,7	61,3	
EER (EN14511) ⁽³⁾	W/W	2,95	2,72	3,10	2,98	3,19	3,01	
Sound power ⁽⁴⁾	dB (A)	75	75	79	79	80	80	
Sound pressure ⁽⁵⁾	dB (A)	43	43	47	47	48	48	
HE/XL/RV - P4U/P4S		1002	1202	1454	1654	1854	2154	
Heating capacity (EN14511) ⁽¹⁾	kW	87,2	100,7	147,6	166,6	187,6	218,2	
Total input power (EN14511) ⁽¹⁾	kW	19,4	23,5	32,3	37,6	41,2	49,5	
COP (EN14511) ⁽¹⁾	W/W	4,49	4,29	4,57	4,43	4,55	4,41	
Energy Class in low temperature ⁽²⁾		A++	A++	A++	A++	A++	A++	
SCOP low temperature ⁽²⁾	kWh/kWh	4,06	3,93	4,10	4,00	3,94	3,92	
η _{s,h} low temperature ⁽²⁾	%	160	154	161	157	154	154	
Energy Class in medium temperature ⁽²⁾		A++	A++	A++	A++	A++	A++	
SCOP medium temperature ⁽²⁾	kWh/kWh	3,33	3,25	3,28	3,29	3,28	3,28	
η _{s,h} medium temperature ⁽²⁾	%	130	127	128	129	128	128	
Cooling capacity (EN14511) ⁽³⁾	kW	76,9	88,1	126,5	142,7	158,7	184,3	
Total input power (EN14511) ⁽³⁾	kW	26,3	32,9	40,3	48,4	49,7	60,3	
EER (EN14511) ⁽³⁾	W/W	2,92	2,68	3,14	2,95	3,19	3,05	
Sound power ⁽⁴⁾	dB (A)	82	81	85	85	87	87	
Sound pressure ⁽⁵⁾	dB (A)	50	49	53	53	55	55	
Power supply	V/Ph/Hz	400/3/50	400/3/50	400/3/50	400/3/50	400/3/50	400/3/50	
Compressors / Circuits	n° / n°	2 / 1	2 / 1	4/2	4/2	4/2	4/2	
Fans	n°	2	2	4	4	6	6	
Refrigerant		R410A	R410A	R410A	R410A	R410A	R410A	
Refrigerant charge	kg	27,0	27,0	50,0	50,0	55,0	55,0	
Global warming potential (GWP)		2088	2088	2088	2088	2088	2088	
Equivalent CO ₂ charge	t	56,37	56,37	104,40	104,40	114,84	114,84	
Water tank volume	l	300	300	500	500	500	500	

Performances are referred to the following conditions:

- (1) Heating: Ambient temperature 7°C DB, 6°C WB, water temperature 30/35°C.
(2) Average conditions, variable - Reg EU 811/2013

(3) Cooling: ambient air temperature 35°C, evaporator water temperature in/out 12/7 °C..

(4) Sound power level in accordance with ISO 3744..

(5) Sound pressure level at 10 mt from the unit in free field conditions in accordance with ISO 3744.

HE/NN/RV - P4U/P4S		252	312	452	502	602	752	852
Heating capacity (EN14511) ⁽¹⁾	kW	23,4	30,5	41,1	54,2	60,7	70,4	79,5
Total input power (EN14511) ⁽¹⁾	kW	5,0	6,4	8,8	11,7	12,4	14,7	17,41
COP (EN14511) ⁽¹⁾	W/W	4,69	4,75	4,69	4,64	4,89	4,78	4,56
Energy Class in low temperature ⁽²⁾		A++	A++	A++	A++	A++	A++	A++
SCOP low temperature ⁽²⁾	kWh/kWh	4,30	4,35	4,23	4,10	4,37	4,40	4,22
η _{s,h} low temperature ⁽²⁾	%	169	171	166	161	172	173	166
Energy Class in medium temperature ⁽²⁾		A++	A++	A++	A++	A++	A++	A++
SCOP medium temperature ⁽²⁾	kWh/kWh	3,34	3,48	3,42	3,34	3,47	3,45	3,38
η _{s,h} medium temperature ⁽²⁾	%	131	136	134	131	136	135	132
Cooling capacity (EN14511) ⁽³⁾	kW	22,1	28,5	37,0	46,4	53,3	61,6	72,9
Total input power (EN14511) ⁽³⁾	kW	6,9	9,1	12,6	14,9	16,8	20,9	25,1
EER (EN14511) ⁽³⁾	W/W	3,20	3,15	2,93	3,11	3,18	2,95	2,90
Sound power ⁽⁴⁾	dB (A)	68	69	71	71	71	72	72
Sound pressure ⁽⁵⁾	dB (A)	36	37	39	39	39	40	40
Power supply	V/Ph/Hz	400/3+N/50	400/3/50	400/3/50	400/3/50	400/3/50	400/3/50	400/3/50
Compressors / Circuits	n° / n°	2 / 1	2 / 1	2 / 1	2 / 1	2 / 1	2 / 1	2 / 1
Fans	n°	2	2	2	2	2	2	2
Refrigerant		R410A	R410A	R410A	R410A	R410A	R410A	R410A
Refrigerant charge	kg	10,0	10,0	18,0	23,0	18,0	23,0	23,0
Global warming potential (GWP)		2088,0	2088	2088	2088	2088	2088	2088
Equivalent CO ₂ charge	t	20,88	20,88	37,58	48,02	37,58	48,02	48,02

HE/NN/RV - P4U/P4S		1002	1202	1454	1654	1854	2154
Heating capacity (EN14511) ⁽¹⁾	kW	90,3	104,9	146,7	165,1	184,7	214,0
Total input power (EN14511) ⁽¹⁾	kW	18,6	22,1	31,5	36,6	40,0	48,0
COP (EN14511) ⁽¹⁾	W/W	4,87	4,75	4,66	4,51	4,62	4,46
Energy Class in low temperature ⁽²⁾		A++	A++	A++	A++	A++	A++
SCOP low temperature ⁽²⁾	kWh/kWh	4,42	4,31	4,31	4,15	4,23	4,12
η _{s,h} low temperature ⁽²⁾	%	174	169	169	163	166	162
Energy Class in medium temperature ⁽²⁾		A++	A++	A++	A++	A++	A++
SCOP medium temperature ⁽²⁾	kWh/kWh	3,52	3,50	3,41	3,40	3,47	3,42
η _{s,h} medium temperature ⁽²⁾	%	138	137	134	133	136	134
Cooling capacity (EN14511) ⁽³⁾	kW	79,0	91,9	124,7	139,5	156,5	179,9
Total input power (EN14511) ⁽³⁾	kW	24,7	29,8	41,5	50,9	50,8	63,3
EER (EN14511) ⁽³⁾	W/W	3,20	3,08	3,01	2,74	3,08	2,84
Sound power ⁽⁴⁾	dB (A)	72	72	74	74	75	75
Sound pressure ⁽⁵⁾	dB (A)	40	40	42	42	43	43
Power supply	V/Ph/Hz	400/3/50	400/3/50	400/3/50	400/3/50	400/3/50	400/3/50
Compressors / Circuits	n° / n°	2 / 1	2 / 1	4/2	4/2	4/2	4/2
Fans	n°	3	3	4	4	6	6
Refrigerant		R410A	R410A	R410A	R410A	R410A	R410A
Refrigerant charge	kg	36,0	36,0	50,0	50,0	55,0	55,0
Global warming potential (GWP)		2088	2088	2088	2088	2088	2088
Equivalent CO ₂ charge	t	75,16	75,16	104,40	104,40	114,84	114,84

Performances are referred to the following conditions:

(1) Heating: Ambient temperature 7°C DB, 6°C WB, water temperature 30/35°C.

(2) Average conditions, variable - Reg EU 811/2013

(3) Cooling: ambient air temperature 35°C, evaporator water temperature in/out 12/7 °C..

(4) Sound power level in accordance with ISO 3744..

(5) Sound pressure level at 10 mt from the unit in free field conditions in accordance with ISO 3744.

Frame

All units are made from hot-galvanised sheet steel, painted with polyurethane powder enamel and stoved at 180°C to provide maximum protection against corrosion. The frame is self-supporting with removable panels. All screws and rivets used are made from stainless steel.

The standard colour of the units is RAL9018.

Refrigerant circuit

The refrigerant utilised is R410A. The refrigerant circuit is assembled using internationally recognised brand name components with all brazing and welding being performed in accordance with ISO 97/23. The refrigerant circuit includes: sight glass, filter drier, two thermal expansion valves (one for cooling mode, one for heating mode) with external equalizer, 4 way reversing valve, check valves, liquid receiver, Schrader valves for maintenance and control, pressure safety device (for compliance with PED regulations). The circuit also includes an AISI316 stainless steel heat exchanger that is used as an economizer plus an additional expansion valve for refrigerant vapour injection.

Compressors

Units use scroll compressors that are equipped with E.V.I. technology, a versatile method of improving system capacity and efficiency. EVI stands for "Enhanced Vapour Injection." The technology involves injecting refrigerant vapour into the middle of the compression process, a procedure that significantly boosts capacity and efficiency. Each scroll compressor used in these units is similar to a two-stage compressor with built-in inter-stage cooling. The process begins when a portion of the condenser liquid is extracted and expanded through an expansion valve. The low temperature liquid/gas mixture produced is injected into a heat exchanger that operates as a sub cooler. Any liquid is evaporated and the vapour produced is superheated.

The superheated vapour is then injected into an intermediate port in the scroll compressor. This cold vapour reduces the temperature of the compressed gas thus enabling the compressor to raise the pressure to levels (and temperatures) beyond that possible with a single stage scroll. The additional sub cooling of the main volume of liquid refrigerant increases the evaporator capacity. This compressor technology generates a larger pressure ratio between condensing and evaporating pressures, with significant performance improvement. In all units the compressors are connected in tandem. The compressors are all supplied with a crankcase heater and thermal overload protection by a klixon embedded in the motor winding. They are mounted in a separate enclosure in order to be separated from the air stream thus enabling them to be maintained even if the unit is operating. Access to this enclosure is by the front panel of the unit. The crankcase heater is always powered when the compressor is in stand-by.

Source heat exchanger

The source heat exchanger is made from copper pipes and aluminium fins. Dimensioning of the copper pipes and the aluminium wings is optimized in order to obtain excellent performance.

The tubes are mechanically expanded into the fins in order to maximise heat transfer. Furthermore, the design guarantees a low air side pressure drop thus enabling the use of low rotation speed (and hence low noise) fans. All heat exchangers are supplied standard with fins hydrophilic coating.

User heat exchangers

The user heat exchanger is a braze welded, plate type heat ex-

changer, manufactured from AISI 316 stainless steel. The use of this type of exchanger results in a massive reduction of the refrigerant charge of the unit compared to a traditional shell-in-tube type. A further advantage is a reduction in the overall dimensions of the unit.

The exchangers are factory insulated with flexible close cell material and can be fitted with an antifreeze heater (accessory). Each exchanger is fitted with a temperature sensor on the discharge water side for antifreeze protection.

Fans

The fans are direct drive axial type with aluminium aerofoil blades, are statically and dynamically balanced and are supplied complete with a safety fan guard complying with the requirements of EN 60335. They are fixed to the unit frame via rubber antivibration mountings. In the LS versions the fans are 6 poles type (approx 900 rpm), in the XL versions the fans are 8 poles type (approx 600 rpm), in the NN versions the fans are 12 poles type (approx 450 rpm). The motors are fitted with integrated thermal overload protection and have a moisture protection rating of IP 54.

Microprocessors

All units are supplied as standard complete with control panel. The microprocessor controls the following functions: control of the water temperature, antifreeze protection, compressor timing, compressor automatic starting sequence (For multiple compressors), alarm reset.

The control panel is supplied with display showing all operational icons. The microprocessor is set for automatic defrost (when operating in severe ambient conditions) and for summer/ winter change over (only for RV versions).

The control also manages the anti-legionella program, the integration with other heating sources (electric heaters, boilers, solar panels etc), the operation of a three port modulating valve (for diverting to DHW or heating) and both the heating circuit pump and the domestic hot water circuit pump. If required (available as an option), the microprocessor can be configured in order for it to connect to a site BMS system thus enabling remote control and management.

Electric enclosure

The enclosure is manufactured in order to comply with the requirements of the electromagnetic compatibility standards CEE EN60204. Access to electrical cabinet in quick and easy thanks to hinged panels. The following components are supplied as standard on all units: main switch, a sequence relay that disables the power supply in the event that the phase sequence is incorrect (scroll compressors can be damaged if they rotate in the wrong direction), thermal overloads (protection of pumps and fans), compressor fuses, control circuit automatic breakers, compressor contactors, fan contactors and pump contactors. The terminal board has volt free contacts for remote ON-OFF, Summer/ winter change over (heat pumps only) and general alarm.

Control and protection devices

All units are supplied with the following controls and protections: user water return temperature sensor, antifreeze protection temperature sensor installed on users water output, domestic hot water supply and return temperature sensors (only versions

P2S), high pressure manual reset, low pressure automatic reset, compressor thermal protection, air fan, thermal protection, pressure transducer (used to optimize the defrost cycle and to adjust the fan speed depending on ambient conditions), flow switch. All units are also fitted with a temperature probe sensor with "Energy Saving" function, supplied in a separate plastic box, which can be used to stop the pump use during periods of stand-by, when the water temperature reaches the set point. Doing this the power consumption of the unit is strongly reduced. The probe sensor

must be positioned in the hydraulic compensator present at the screening technique. The domestic hot water circuit (only versions P2S) is already equipped with this probe, but it must be installed in the user circuit.

Versions

P4U version

The P4U units use 4 hydraulic connections and are used in modern 4-pipe systems. In these systems, cold and hot water is always available (in every period of the year) and present in the specific hydraulic circuit.

These systems allow the simultaneous production of cold water and hot water using 4 hydraulic connections, 2 connections are related to the hot water circuit, 2 connections are related to the cold water circuit.

The plant thus conceived is able to heat and, at the same time, if required, to cool with very high energy efficiencies. In this configuration, however, the units are also able to produce hot or cold water separately at any time of the year.

The units are supplied with 2 heat exchangers, one dedicated to the production of cold water and one dedicated to the production of hot water.

The operating modes are:

1. User water heating: The unit behaves like a normal air/water heat pump in heating mode, using the finned heat exchanger as the source and the A plate heat exchanger as user.

2. User water cooling: The unit behaves like a normal air / water chiller in cooling mode, using the finned exchanger as the source

and the B plate heat exchanger as user.

3. Simultaneous user Cooling + heating: The unit behaves like a water / water heat pump, using the plate heat exchanger B as the cold user and the plate heat exchanger A as hot user. This version is not able to produce domestic hot water.

P4S Version

The P4S units have been designed to meet the needs of 2 + 2 pipe systems (2 user side pipes, 2 domestic hot water pipes) throughout the year. The units are supplied with 2 exchangers, one dedicated to the production of the user cold and hot water and one dedicated to the production of domestic hot water only (D.H.W.). The production of domestic hot water always has priority. In winter mode the activation of D.H.W. production temporarily stops the production of the user hot water, which is restored when the D.H.W. accumulation reaches the temperature set. In summer mode the unit will switch to cooling (by activating the reverse cycle valve installed in the refrigerant circuit) and any request for domestic hot water will allow, at the same time, the production of cold water. In this operating mode, the system can simultaneously produce cold water and domestic hot water. Domestic hot water, in summer mode, is produced by heat recovery and therefore free of charge. When the temperature measured by the D.H.W. sensor reaches the set, the D.H.W. water pump is stopped and normal operation is restored in cooling mode.

P4U version

User water heating

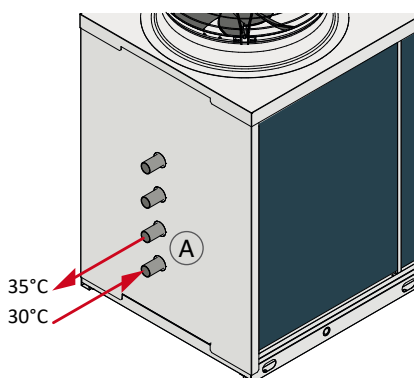

User water cooling

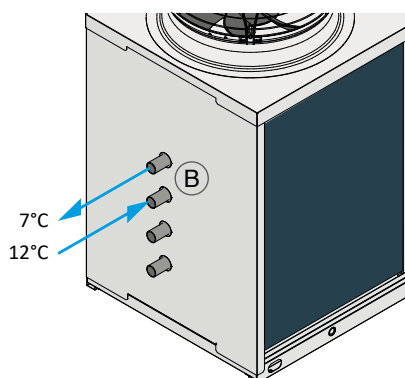

Simultaneous user Cooling + heating

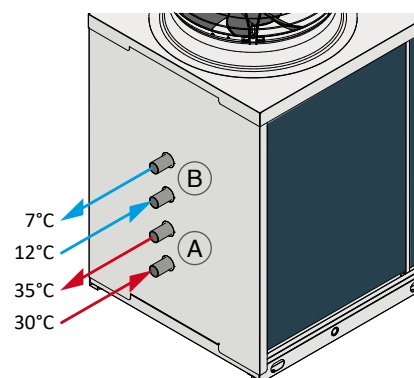

The above scheme is for illustrative purposes only. For the correct pipes placement, please refer to the units technical manual.

The operating modes are:

1. User water heating: The unit behaves like a normal air/water heat pump in heating mode, using the finned heat exchanger as the source and the A plate heat exchanger as user.

2. User water cooling: The unit behaves like a normal air/water chiller in cooling mode, using the finned heat exchanger as the source and the A plate heat exchanger as user.

3. Domestic hot water production (D.H.W.): The unit behaves like a normal air / water heat pump in heating mode, using the finned heat exchanger as the source and as a user the plate heat exchanger B (a special D.H.W. heat exchanger that works with a higher set point).

4. User water cooling + D.H.W. production: The unit behaves like a water / water heat pump, using the plate heat exchanger A as the cold user and the plate heat exchanger B as D.H.W. production).

SA Version

Standard efficiency version, according to current standard. Unit equipped with AC fans.

SE Version

Standard efficiency version, according to current standard. Unit equipped with EC fans.

HA Version

High efficiency version, according to current standard. Unit equipped with AC fans.

HE Version

High efficiency version, according to current standard. Unit equipped with EC fans.

Version LS

This version includes the complete acoustic insulation of the unit with compressor jackets and insulating material made with high density media and the interposition of heavy bitumen layer.

**Super low noise and ultra low noise versions
XL and NN**

All units in XL and NN versions are supplied, as standard, with the latest 'Floating Frame' technology that completely isolates the compressors from the main casing, thereby eliminating vibration and noise from this source. The 'Floating Frame' is a special vibration and acoustic damping system that consists of a base plate and acoustic enclosure that houses the compressors. The base plate is separated from the supporting frame of the unit by soft steel springs that have a high damping power. Within the enclosure, the compressors are mounted on rubber shock absorbers on the floating base plate. The enclosure is manufactured from galvanized steel sandwich panels that have a micro-perforated inner skin and a core of 30 mm thick, high density (25 kg/m³). The entire arrangement provides a double damping system and acoustic attenuation. The compressor refrigerant pipes are connected to the refrigerant circuit through "anaconda" flexible connections. Flexible connections are also used on the water pipework within the unit. The combination of these systems results in an overall noise reduction in the region of 6-8 dB(A).

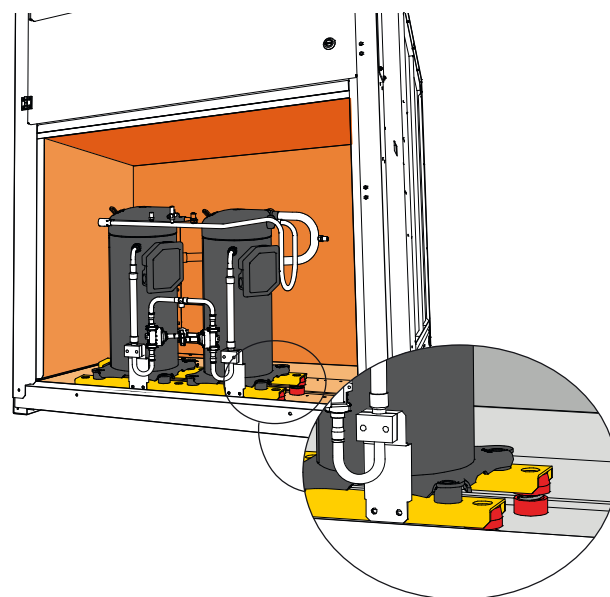

P4S version

User water heating

User water cooling

Domestic hot water production (D.H.W.)

User water cooling + D.H.W. production

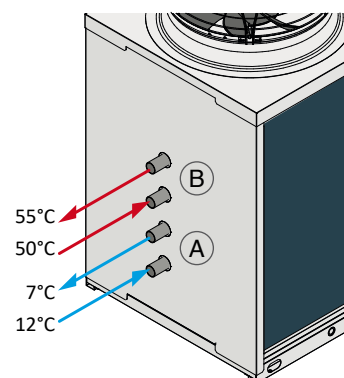
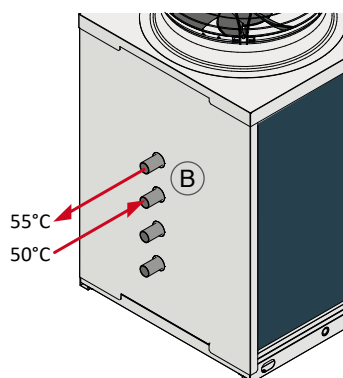
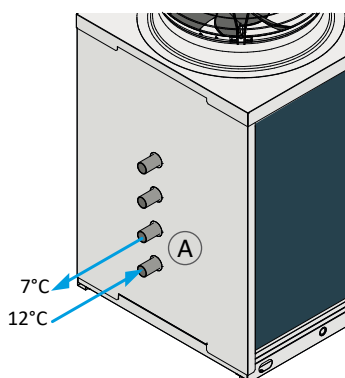
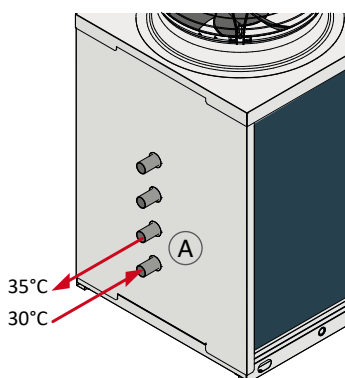

The above scheme is for illustrative purposes only. For the correct pipes placement, please refer to the units technical manual.

Operation limits

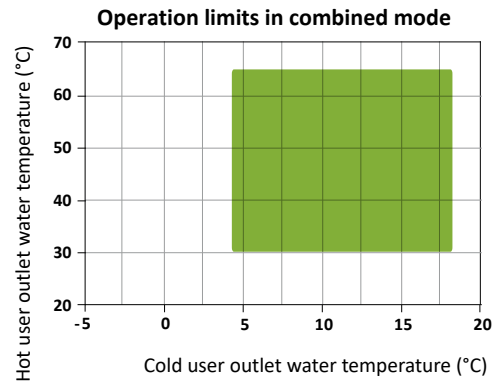
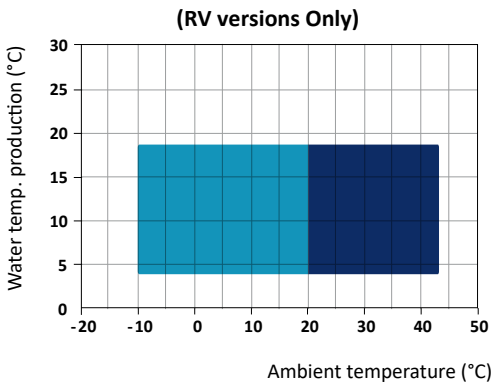
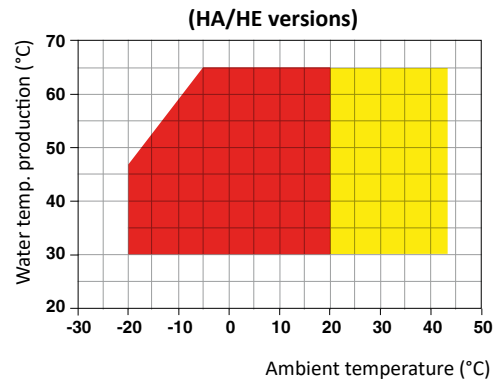
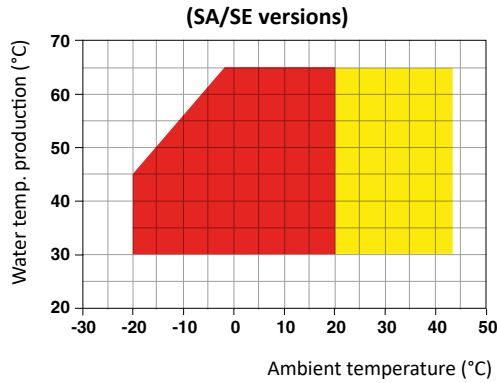

- Heating mode
- Cooling mode
- Heating mode with head pressure control (DCCF)
- Cooling with head pressure control (DCCF)
- Combined mode

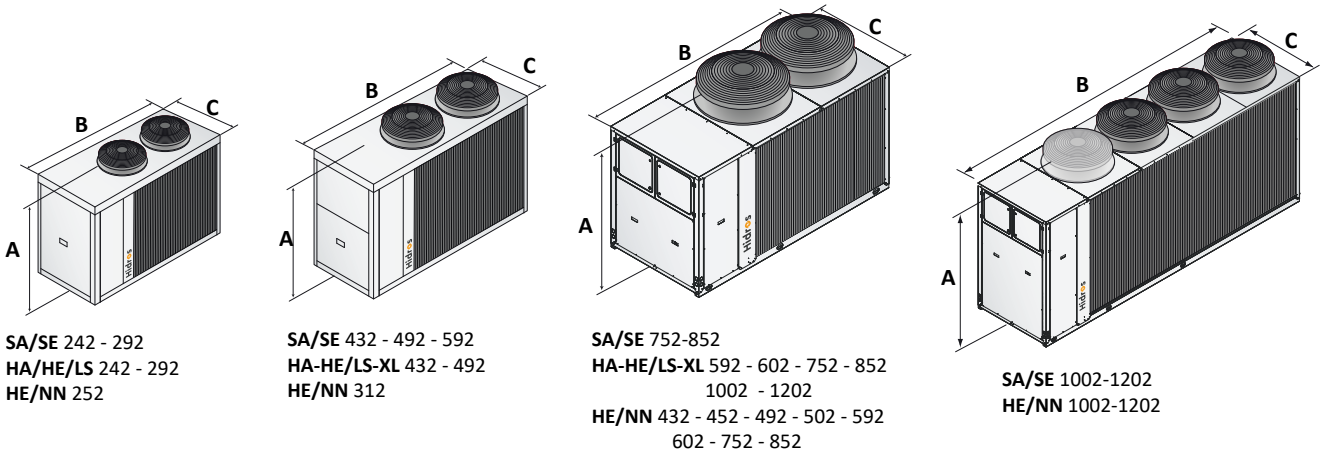

		242/252	292/302	312	432	452	492	502	592	602
A (mm)	SA-SE/LS	1500	1500	--	1690	--	1690	--	1690	--
B (mm)	SA-SE/LS	1915	1915	--	2400	--	2400	--	2400	--
C (mm)	SA-SE/LS	875	875	--	1145	--	1145	--	1145	--
kg	SA-SE/LS	1000	1000	--	1500	--	1500	--	1500	--
A (mm)	HA-HE/LS	1500	1500	--	1690	--	1690	--	--	1820
B (mm)	HA-HE/LS	1915	1915	--	2400	--	2400	--	--	2905
C (mm)	HA-HE/LS	875	875	--	1145	--	1145	--	--	1150
kg	HA-HE/LS	1000	1000	--	1500	--	1500	--	--	1060
A (mm)	HA-HE/XL	1500	1500	--	1690	--	1690	--	--	1820
B (mm)	HA-HE/XL	1915	1915	--	2400	--	2400	--	--	2905
C (mm)	HA-HE/XL	875	875	--	1145	--	1145	--	--	1150
kg	HA-HE/XL	1000	1000	--	1500	--	1500	--	--	1080
A (mm)	HE/NN	1500	1500	1690	--	1820	--	1820	--	1820
B (mm)	HE/NN	1915	1915	2400	--	2905	--	2905	--	2905
C (mm)	HE/NN	875	875	1145	--	1150	--	1150	--	1150
kg	HE/NN	1000	1000	1500	--	1080	--	1100	--	1110

LZT		252	302	312	432	452	492	502	592	602	752	852	1002	1202	1454	1654	1854	2154	
Flow switch		●	●	●	●	●	●	●	●	●	●	●	●	●	●	●	●	●	●
"Floating frame" Technology - LS Version		-	-	-	-	-	-	-	-	-	-	-	-	-	-	-	-	-	-
"Floating frame" Technology - XL - NN Version		●	●	●	●	●	●	●	●	●	●	●	●	●	●	●	●	●	●
E.C. fans - SA/LS versions	VECE	-	-	-	-	-	-	-	-	-	-	-	-	-	-	-	-	-	-
E.C. fans - SE/LS versions	VECE	●	●	●	●	●	●	●	●	●	●	●	●	●	●	●	●	●	●
E.C. fans - HA/LS - HA/XL versions	VECE	-	-	-	-	-	-	-	-	-	-	-	-	-	-	-	-	-	-
E.C. fans - HE/LS - HE/XL - HE/NN versions	VECE	●	●	●	●	●	●	●	●	●	●	●	●	●	●	●	●	●	●
Condensate discharge drip tray with antifreeze heater	BRCA	○	○	○	○	○	○	○	○	○	○	○	○	○	○	○	○	○	○
Condensing pressure control by transducer & EC Fans (only for SE and HA)	CP	●	●	●	●	●	●	●	●	●	●	●	●	●	●	●	●	●	●
Fans regulation by phase cut (only SA - HA)	DCCF	●	●	●	●	●	●	●	●	●	●	●	●	●	●	●	●	●	●
Antifreeze kit for 4 pipe units	RAEV4	○	○	○	○	○	○	○	○	○	○	○	○	○	○	○	○	○	○
Electronic soft starter	DSSE	○	○	○	○	○	○	○	○	○	○	○	○	○	○	○	○	○	○
Serial interface card RS485	INSE	●	●	●	●	●	●	●	●	●	●	●	●	●	●	●	●	●	●
Rubber anti-vibration mountings	KAVG	○	○	○	○	○	○	○	○	○	○	○	○	○	○	○	○	○	○
Remote control panel	PCRL	○	○	○	○	○	○	○	○	○	○	○	○	○	○	○	○	○	○
Electronic expansion valve	VTEE	○	○	○	○	○	○	○	○	○	○	○	○	○	○	○	○	○	○
Cascade control system via RS485	SGRS	○	○	○	○	○	○	○	○	○	○	○	○	○	○	○	○	○	○
Hydraulic kit with one pump with tank *	A1ZZU	○	○	○	○	○	○	○	○	○	○	○	○	○	○	○	○	○	○
Hydraulic kit with two pumps with tank *	A2ZZU	○	○	○	○	○	○	○	○	○	○	○	○	○	○	○	○	○	○
Hydraulic kit with one pump without tank *	A1NTU	○	○	○	○	○	○	○	○	○	○	○	○	○	○	○	○	○	○
Hydraulic kit with two pumps without tank *	A2NTU	○	○	○	○	○	○	○	○	○	○	○	○	○	○	○	○	○	○

* Not available for NN versions

● Standard ○ Optional – Not available

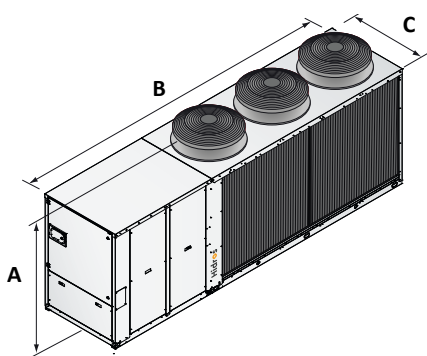

HA-HE/LS 1454 - 1654
1854 - 2154

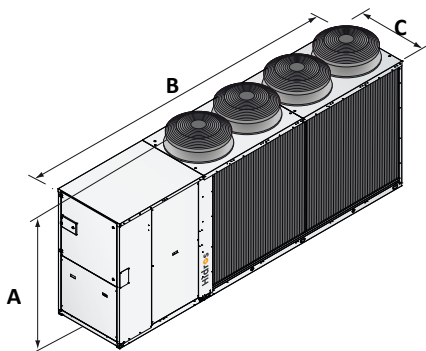

SA-SE/LS 1454 - 1654
1854 - 2154

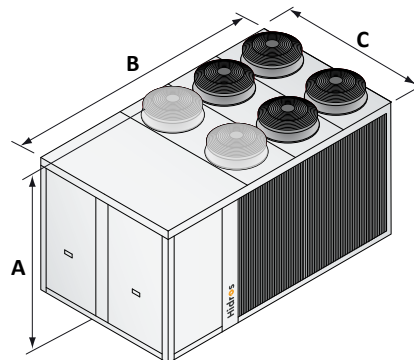

HA-HE/XL 1454 - 1654 - 1854 - 2154
HE/NN 1454 - 1654 - 1854 - 2154

		752	852	1002	1202	1454	1654	1854	2154
A (mm)	SA-SE/LS	1880	1880	1890	1890	2310	2310	2310	2310
B (mm)	SA-SE/LS	2905	2905	3905	3905	5300	5300	5300	5300
C (mm)	SA-SE/LS	1145	1145	1145	1145	1145	1145	1145	1145
kg	SA-SE/LS	2000	2000	2000	2000	2500	2540	2580	2620
A (mm)	HA-HE/LS	1880	1880	1840	1840	1895	1895	1895	1895
B (mm)	HA-HE/LS	2905	2905	2905	2905	4695	4695	4695	4695
C (mm)	HA-HE/LS	1145	1145	1145	1145	1145	1145	1145	1145
kg	HA-HE/LS	2000	2000	2000	2000	2580	2640	2720	2760
A (mm)	HA-HE/XL	1880	1880	1840	1840	2350	2350	2350	2350
B (mm)	HA-HE/XL	2905	2905	2905	2905	4205	4205	4205	4205
C (mm)	HA-HE/XL	1145	1145	1145	1145	2210	2210	2210	2210
kg	HA-HE/XL	2000	2000	2000	2000	2500	2540	2580	2620
A (mm)	HE/NN	1880	1880	1890	1890	2350	2350	2350	2350
B (mm)	HE/NN	2905	2905	3905	3905	4205	4205	4205	4205
C (mm)	HE/NN	1145	1145	1145	1145	2210	2210	2210	2210
kg	HE/NN	2000	2000	2000	2000	2750	2800	2840	2890