

LDA

Air cooled water chillers with axial fans



LDA water chillers are efficient, low-noise products designed for medium to large applications.

They are suitable for generating chilled water at temperatures in the region of 7°C, commonly used in applications with fan coils and/or air handling units.

The use of tandem scroll compressors results in high efficiencies (especially at part loads) and low noise levels, making them suitable for use in many applications.

Differing versions and a wide range of accessories, enable the optimal solution to be selected.

Versions

- CO** Cooling only.
- SA** Standard efficiency, AC fans.
Only for the non-EU market
- SE** Standard efficiency, EC fans.
- HA** High efficiency, AC fans.
- HE** High efficiency, EC fans.
- LS** Low noise.
- XL** Extra low noise.
- BT** Cooling only for low user water temperature.
- CN** Condensing unit version.

HA/LS/CO		242	292	412	432	492	602	702	802	902	1002	1202	1402
Cooling capacity (EN14511) ⁽¹⁾	kW	19,6	26,7	32,3	42,8	46,8	55,0	61,5	68,4	82,6	93,5	104,5	121,4
Total input power (EN14511) ⁽¹⁾	kW	6,3	8,6	10,3	13,8	15,0	17,1	19,6	22,0	26,2	30,0	33,6	38,1
EER (EN14511) ⁽¹⁾	W/W	3,10	3,11	3,13	3,11	3,11	3,22	3,13	3,11	3,15	3,12	3,11	3,19
SEER ⁽²⁾	kWh/kWh	4,11	4,20	4,19	4,11	4,12	4,20	4,19	4,19	4,14	4,13	4,12	4,13
η _{s,c} ⁽²⁾	%	161	161	164	162	162	165	165	165	163	162	162	162
Sound power ⁽³⁾	dB (A)	75	75	75	75	77	77	77	78	83	84	85	87
Sound pressure ⁽⁴⁾	dB (A)	43	43	43	43	45	45	45	46	51	52	53	55
Water tank volume	l	100	100	100	100	100	300	300	300	300	300	300	500
HE/LS/CO		242	292	412	432	492	602	702	802	902	1002	1202	1402
Cooling capacity (EN14511) ⁽¹⁾	kW	19,7	26,7	32,0	42,8	46,6	55	61,6	68,6	82,6	93,8	105	121,6
Total input power (EN14511) ⁽¹⁾	kW	6,2	8,4	10,0	13,6	14,8	16,9	19,3	21,8	25,4	29,6	33,2	36,8
EER (EN14511) ⁽¹⁾	W/W	3,16	3,18	3,19	3,15	3,14	3,25	3,19	3,15	3,25	3,17	3,16	3,30
SEER ⁽²⁾	kWh/kWh	4,20	4,25	4,35	4,29	4,26	4,39	4,31	4,24	4,37	4,34	4,25	4,40
η _{s,c} ⁽²⁾	%	165	167	171	168	167	173	169	167	172	171	167	173
Sound power ⁽³⁾	dB (A)	76	78	78	80	80	81	81	82	85	88	88	89
Sound pressure ⁽⁴⁾	dB (A)	44	46	46	48	48	49	49	50	53	56	56	57
Power supply	V/Ph/Hz	400/3+N/50	400/3+N/50	400/3/50	400/3/50	400/3/50	400/3/50	400/3/50	400/3/50	400/3/50	400/3/50	400/3/50	400/3/50
Compressors / Circuits	n° / n°	2 / 1	2 / 1	2 / 1	2 / 1	2 / 1	2 / 1	2 / 1	2 / 1	2 / 1	2 / 1	2 / 1	2 / 1
Fans	n°	1	1	2	2	2	2	2	2	2	2	2	3
Refrigerant		R410A	R410A	R410A	R410A	R410A	R410A	R410A	R410A	R410A	R410A	R410A	R410A
Refrigerant charge	kg	6,5	6,5	6,5	10,0	8,5	8,5	14,5	14,5	19,0	19,0	20,0	28,0
Global warming potential (GWP)		2088	2088	2088	2088	2088	2088	2088	2088	2088	2088	2088	2088
Equivalent CO ₂ charge	t	13,57	13,57	13,57	20,88	17,74	17,74	30,27	30,27	39,67	39,67	41,76	58,46
Water tank volume	l	100	100	100	100	100	300	300	300	300	300	300	500

HA/LS/CO		1602	1802	2002	2302	2502	2504	3004	3204	3504	4004	4504
Cooling capacity (EN14511) ⁽¹⁾	kW	133,3	151,6	168,9	195,0	214,5	208,8	242,5	266,0	301,1	340,5	390,0
Total input power (EN14511) ⁽¹⁾	kW	42,9	48,7	54,3	62,7	68,8	67,1	77,5	85,3	96,8	109,5	125,4
EER (EN14511) ⁽¹⁾	W/W	3,11	3,11	3,11	3,11	3,12	3,11	3,13	3,12	3,11	3,11	3,11
SEER ⁽²⁾	kWh/kWh	4,19	4,13	4,17	4,18	4,13	4,12	4,13	4,15	4,17	4,19	4,18
η _{s,c} ⁽²⁾	%	165	162	164	164	162	162	162	163	164	165	164
Sound power ⁽³⁾	dB (A)	88	88	88	89	91	89	90	91	91	91	93
Sound pressure ⁽⁴⁾	dB (A)	56	56	56	57	59	57	58	59	59	59	61
Water tank volume	l	500	500	5000	500	1000	1000	1000	1000	1000	1000	1000
HE/LS/CO		1602	1802	2002	2302	2502	2504	3004	3204	3504	4004	4504
Cooling capacity (EN14511) ⁽¹⁾	kW	133,3	152,1	169,3	195,6	215,1	210,3	246,8	267,7	303,2	345,3	390
Total input power (EN14511) ⁽¹⁾	kW	41,8	48,1	53,6	62,7	68,3	66,3	76,2	85,0	95,3	108,2	123,8
EER (EN14511) ⁽¹⁾	W/W	3,19	3,16	3,16	3,12	3,15	3,17	3,24	3,15	3,18	3,19	3,15
SEER ⁽²⁾	kWh/kWh	4,42	4,41	4,31	4,40	4,28	4,25	4,36	4,32	4,41	4,28	4,43
η _{s,c} ⁽²⁾	%	174	175	169	173	168	167	171	170	173	168	174
Sound power ⁽³⁾	dB (A)	89	91	91	92	92	91	91	92	93	94	96
Sound pressure ⁽⁴⁾	dB (A)	57	59	59	60	60	59	59	60	61	62	64
Power supply	V/Ph/Hz	400/3/50	400/3/50	400/3/50	400/3/50	400/3/50	400/3/50	400/3/50	400/3/50	400/3/50	400/3/50	400/3/50
Compressors / Circuits	n° / n°	2 / 1	2 / 1	2 / 1	2 / 1	2 / 1	4 / 2	4 / 2	4 / 2	4 / 2	4 / 2	4 / 2
Fans	n°	3	3	3	3	3	4	6	6	6	6	8
Refrigerant		R410A	R410A	R410A	R410A	R410A	R410A	R410A	R410A	R410A	R410A	R410A
Refrigerant charge	kg	30,0	30,0	30,0	30,0	40,0	40,0	50,0	60,0	50,0	60,0	90,0
Global warming potential (GWP)		2088	2088	2088	2088	2088	2088	2088	2088	2088	2088	2088
Equivalent CO ₂ charge	t	62,64	62,64	62,64	62,64	83,52	83,52	104,40	152,28	104,40	152,28	187,92
Water tank volume	l	500	500	5000	500	1000	1000	1000	1000	1000	1000	1000

Performances are referred to the following conditions:

- (1) Cooling: ambient air temperature 35°C, evaporator water temperature in/out 12/7 °C.
(2) In accordance with (EU) 2016/2281 and relative norms part of this.

(3) Sound power level in accordance with ISO 3744.

(4) Sound pressure level at 10 mt from the unit in free field conditions in accordance with ISO 3744.

SE/XL/CO		252	302	402	432	492	592	702	802	1002	1202	1402
Cooling capacity (EN14511) ⁽¹⁾	kW	18,5	25,4	29,4	39,7	44,4	50,6	55,8	63,0	85,2	92,7	105,2
Total input power (EN14511) ⁽¹⁾	kW	6,5	9,1	10,4	13,9	15,0	18,3	21,1	22,9	31,3	36,8	40,9
EER (EN14511) ⁽¹⁾	W/W	2,84	2,81	2,82	2,87	2,96	2,77	2,64	2,75	2,72	2,52	2,57
SEER ⁽²⁾	kWh/kWh	4,14	4,12	4,14	4,11	4,12	4,15	4,11	4,12	4,13	4,11	4,15
$\eta_{s,c}$ ⁽²⁾	%	163	162	163	161	162	163	162	162	162	162	163
Sound power ⁽³⁾	dB (A)	68	69	69	77	80	80	80	80	85	85	86
Sound pressure ⁽⁴⁾	dB (A)	36	37	37	45	48	48	48	48	53	53	54
Power supply	V/Ph/Hz	400/3+N/50	400/3+N/50	400/3+N/50	400/3/50	400/3/50	400/3/50	400/3/50	400/3/50	400/3/50	400/3/50	400/3/50
Compressors / Circuits	n° / n°	2 / 1	2 / 1	2 / 1	2 / 1	2 / 1	2 / 1	2 / 1	2 / 1	2 / 1	2 / 1	2 / 1
Fans	n°	2	2	2	2	2	2	2	2	3	3	3
Refrigerant		R410A	R410A	R410A	R410A	R410A	R410A	R410A	R410A	R410A	R410A	R410A
Refrigerant charge	kg	6,5	6,5	6,5	8,5	8,5	8,5	8,5	14,5	17,0	17,0	17,0
Global warming potential (GWP)		2088	2088	2088	2088	2088	2088	2088	2088	2088	2088	2088
Equivalent CO ₂ charge	t	13,57	13,57	13,57	17,74	17,74	17,74	17,74	30,27	35,49	35,49	35,49
Water tank volume	l	100	100	100	100	100	100	300	300	500	500	500

SE/XL/CO		1602	1802	2002	2302	2502	2504	3004	3204	3504	4004	4504	5004
Cooling capacity (EN14511) ⁽¹⁾	kW	118,0	135,5	148,2	175,9	198,0	193,1	210,6	232,2	286,8	314,4	355,2	395,0
Total input power (EN14511) ⁽¹⁾	kW	44,9	51,5	59,8	65,6	72,8	71,5	83,2	92,5	99,9	115,2	131,6	144,2
EER (EN14511) ⁽¹⁾	W/W	2,63	2,63	2,48	2,68	2,72	2,70	2,53	2,51	2,87	2,73	2,70	2,74
SEER ⁽²⁾	kWh/kWh	4,12	4,14	4,12	4,15	4,13	4,13	4,15	4,12	4,15	4,14	4,13	4,15
$\eta_{s,c}$ ⁽²⁾	%	162	163	162	163	162	162	163	162	163	163	162	163
Sound power ⁽³⁾	dB (A)	87	87	87	91	92	90	90	91	92	92	92	94
Sound pressure ⁽⁴⁾	dB (A)	55	55	55	59	60	58	58	59	60	60	60	62
Power supply	V/Ph/Hz	400/3/50	400/3/50	400/3/50	400/3/50	400/3/50	400/3/50	400/3/50	400/3/50	400/3/50	400/3/50	400/3/50	400/3/50
Compressors / Circuits	n° / n°	2 / 1	2 / 1	2 / 1	2 / 1	2 / 1	4 / 2	4 / 2	4 / 2	4 / 2	4 / 2	4 / 2	4 / 2
Fans	n°	4	4	4	3	4	4	4	4	6	6	6	8
Refrigerant		R410A	R410A	R410A	R410A	R410A	R410A	R410A	R410A	R410A	R410A	R410A	R410A
Refrigerant charge	kg	18,0	30,0	25,0	33,0	33,0	40,0	40,0	50,0	60,0	70,0	90,0	90,0
Global warming potential (GWP)		2088	2088	2088	2088	2088	2088	2088	2088	2088	2088	2088	2088
Equivalent CO ₂ charge	t	37,58	62,64	52,20	69,90	69,90	83,52	83,52	104,40	152,28	146,16	187,92	187,92
Water tank volume	l	500	500	500	500	500	500	500	500	1000	1000	1000	1000

Performances are referred to the following conditions:

(1) Cooling: ambient air temperature 35°C, evaporator water temperature in/out 12/7 °C.

(2) In accordance with (EU) 2016/2281 and relative norms part of this

(3) Sound power level in accordance with ISO 3744.

(4) Sound pressure level at 10 mt from the unit in free field conditions in accordance with ISO 3744.

HA/XL/CO		252	302	412	432	492	602	702	802	902	1002	1202	1402
Cooling capacity (EN14511) ⁽¹⁾	kW	20,5	27,0	31,9	42,6	46,1	54,0	61,2	68,1	80,7	91,2	103,2	118,8
Total input power (EN14511) ⁽¹⁾	kW	6,6	8,7	10,2	13,7	14,9	17,4	19,6	22,0	25,4	29,4	33,3	36,9
EER (EN14511) ⁽¹⁾	W/W	3,11	3,10	3,14	3,11	3,10	3,11	3,12	3,10	3,18	3,10	3,10	3,22
SEER ⁽²⁾	kWh/kWh	4,14	4,11	4,15	4,13	4,11	4,16	4,15	4,15	4,16	4,17	4,16	4,20
$\eta_{s,c}$ ⁽²⁾	%	162	161	163	162	161	163	163	163	163	164	163	165
Sound power ⁽³⁾	dB (A)	70	70	70	70	72	72	72	73	75	77	78	80
Sound pressure ⁽⁴⁾	dB (A)	38	38	38	38	40	40	40	41	43	45	46	48
Water tank volume	l	100	100	100	100	100	300	300	300	300	300	300	500
HE/XL/CO		252	302	412	432	492	602	702	802	902	1002	1202	1402
Cooling capacity (EN14511) ⁽¹⁾	kW	20,5	27,0	31,4	42,6	46,1	54,0	61,2	68,1	80,7	91,2	103,2	118,8
Total input power (EN14511) ⁽¹⁾	kW	6,6	8,7	10,1	13,7	14,8	17,2	19,6	21,9	25,4	29,2	33,2	36,9
EER (EN14511) ⁽¹⁾	W/W	3,12	3,11	3,12	3,11	3,11	3,14	3,13	3,11	3,18	3,12	3,11	3,22
SEER ⁽²⁾	kWh/kWh	4,35	4,32	4,44	4,25	4,30	4,35	4,30	4,25	4,40	4,43	4,30	4,50
$\eta_{s,c}$ ⁽²⁾	%	171	170	175	167	169	171	169	167	173	174	169	177
Sound power ⁽³⁾	dB (A)	64	65	74	70	76	76	76	77	82	84	84	86
Sound pressure ⁽⁴⁾	dB (A)	32	33	42	38	44	44	44	45	50	52	52	54
Power supply	V/Ph/Hz	400/3+N/50	400/3+N/50	400/3/50	400/3/50	400/3/50	400/3/50	400/3/50	400/3/50	400/3/50	400/3/50	400/3/50	400/3/50
Compressors / Circuits	n° / n°	2 / 1	2 / 1	2 / 1	2 / 1	2 / 1	2 / 1	2 / 1	2 / 1	2 / 1	2 / 1	2 / 1	2 / 1
Fans	n°	2	2	2	2	2	2	2	2	2	2	2	3
Refrigerant		R410A	R410A	R410A	R410A	R410A	R410A	R410A	R410A	R410A	R410A	R410A	R410A
Refrigerant charge	kg	6,5	6,5	6,5	10,0	8,5	8,5	14,5	14,5	19,0	19,0	20,0	28,0
Global warming potential (GWP)		2088	2088	2088	2088	2088	2088	2088	2088	2088	2088	2088	2088
Equivalent CO ₂ charge	t	13,57	13,57	13,57	20,88	17,74	17,74	30,27	30,27	39,67	39,67	41,76	58,46
Water tank volume	l	100	100	100	100	100	300	300	300	300	300	300	500

HA/XL/CO		1602	1802	2002	2302	2502	2504	3004	3204	3504	4004	4504
Cooling capacity (EN14511) ⁽¹⁾	kW	130,1	150,1	166,8	189,1	211,0	208,5	236,0	264,0	297,8	337,4	383,5
Total input power (EN14511) ⁽¹⁾	kW	42,0	48,1	53,8	60,8	67,8	67,3	75,6	84,9	95,8	108,5	123,7
EER (EN14511) ⁽¹⁾	W/W	3,10	3,12	3,11	3,11	3,11	3,10	3,12	3,11	3,11	3,11	3,10
SEER ⁽²⁾	kWh/kWh	4,11	4,25	4,12	4,27	4,15	4,14	4,22	4,20	4,30	4,20	4,25
$\eta_{s,c}$ ⁽²⁾	%	161	167	162	168	163	163	166	165	169	165	167
Sound power ⁽³⁾	dB (A)	81	81	81	83	84	81	83	84	84	84	86
Sound pressure ⁽⁴⁾	dB (A)	49	49	49	51	52	49	51	52	52	52	54
Water tank volume	l	500	500	500	500	500	1000	1000	1000	1000	1000	1000
HE/XL/CO		1602	1802	2002	2302	2502	2504	3004	3204	3504	4004	4504
Cooling capacity (EN14511) ⁽¹⁾	kW	130,1	150,1	166,8	189,1	211,0	208,5	236,0	264,0	297,8	337,4	383,5
Total input power (EN14511) ⁽¹⁾	kW	42,0	48,1	53,6	60,8	67,8	67,3	75,6	84,9	95,4	108,5	122,9
EER (EN14511) ⁽¹⁾	W/W	3,10	3,12	3,11	3,11	3,11	3,10	3,12	3,11	3,12	3,11	3,12
SEER ⁽²⁾	kWh/kWh	4,40	4,45	4,35	4,35	4,28	4,30	4,40	4,35	4,38	4,30	4,40
$\eta_{s,c}$ ⁽²⁾	%	173	175	171	171	168	169	173	171	172	169	173
Sound power ⁽³⁾	dB (A)	83	86	87	89	87	87	88	88	89	89	92
Sound pressure ⁽⁴⁾	dB (A)	53	54	55	57	55	55	56	56	57	57	60
Power supply	V/Ph/Hz	400/3/50	400/3/50	400/3/50	400/3/50	400/3/50	400/3/50	400/3/50	400/3/50	400/3/50	400/3/50	400/3/50
Compressors / Circuits	n° / n°	2 / 1	2 / 1	2 / 1	2 / 1	2 / 1	4 / 2	4 / 2	4 / 2	4 / 2	4 / 2	4 / 2
Fans	n°	3	3	3	3	3	4	6	6	6	6	8
Refrigerant		R410A	R410A	R410A	R410A	R410A	R410A	R410A	R410A	R410A	R410A	R410A
Refrigerant charge	kg	30,0	30,0	30,0	30,0	40,0	40,0	50,0	60,0	50,0	60,0	90,0
Global warming potential (GWP)		2088	2088	2088	2088	2088	2088	2088	2088	2088	2088	2088
Equivalent CO ₂ charge	t	62,64	62,64	62,64	62,64	83,52	83,52	104,40	152,28	104,40	152,28	187,92
Water tank volume	l	500	500	500	500	500	1000	1000	1000	1000	1000	1000

Performances are referred to the following conditions:

- (1) Cooling: ambient air temperature 35°C, evaporator water temperature in/out 12/7 °C.
(2) In accordance with (EU) 2016/2281 and relative norms part of this

(3) Sound power level in accordance with ISO 3744.

(4) Sound pressure level at 10 mt from the unit in free field conditions in accordance with ISO 3744.

Units only available for the non-EU market

SA/LS/CO		242	292	402	432	492	592	702	802	902	1002	1202	1402
Cooling capacity (EN14511) ⁽¹⁾	kW	18,7	25,3	30,0	40,5	46,1	51,8	57,1	64,4	73,4	87,0	95,0	108,2
Total input power (EN14511) ⁽¹⁾	kW	6,6	9,2	10,8	14,0	16,6	19,6	20,9	22,7	27,6	31,1	36,0	40,1
EER (EN14511) ⁽¹⁾	W/W	2,83	2,76	2,77	2,90	2,77	2,64	2,73	2,84	2,66	2,80	2,64	2,70
SEER ⁽²⁾	kWh/kWh	3,85	3,90	3,83	3,81	3,82	3,84	3,88	3,85	3,80	3,83	3,81	3,85
η _{s,c} ⁽²⁾	%	151	153	150	149	150	151	152	151	149	150	149	151
Sound power ⁽³⁾	dB (A)	75	75	75	75	77	77	77	78	79	82	83	85
Sound pressure ⁽⁴⁾	dB (A)	43	43	43	43	45	45	45	46	47	50	51	53
Water tank volume	l	100	100	100	100	100	100	300	300	300	500	500	500
SE/LS/CO		242	292	402	432	492	592	702	802	902	1002	1202	1402
Cooling capacity (EN14511) ⁽¹⁾	kW	18,5	25,3	29,8	40,3	46,1	52,1	57,6	65,0	74,0	87,0	95,0	109,1
Total input power (EN14511) ⁽¹⁾	kW	6,6	9,2	10,8	13,8	16,4	19,5	20,7	22,5	27,4	30,6	35,6	39,7
EER (EN14511) ⁽¹⁾	W/W	2,82	2,76	2,77	2,93	2,80	2,68	2,78	2,89	2,70	2,84	2,67	2,75
SEER ⁽²⁾	kWh/kWh	4,02	4,05	4,00	3,95	3,96	3,97	3,97	3,96	3,90	3,95	3,99	4,00
η _{s,c} ⁽²⁾	%	158	159	157	155	155	1556	156	155	153	155	157	157
Sound power ⁽³⁾	dB (A)	73	74	74	75	82	82	82	82	83	87	86	87
Sound pressure ⁽⁴⁾	dB (A)	41	42	42	43	50	50	50	50	51	55	54	55
Power supply	V/Ph/Hz	400/3+N/50	400/3+N/50	400/3+N/50	400/3/50	400/3/50	400/3/50	400/3/50	400/3/50	400/3/50	400/3/50	400/3/50	400/3/50
Compressors / Circuits	n° / n°	2 / 1	2 / 1	2 / 1	2 / 1	2 / 1	2 / 1	2 / 1	2 / 1	2 / 1	2 / 1	2 / 1	2 / 1
Fans	n°	1	1	2	2	2	2	2	2	2	3	3	3
Refrigerant		R410A	R410A	R410A	R410A	R410A	R410A	R410A	R410A	R410A	R410A	R410A	R410A
Refrigerant charge	kg	6,5	6,5	6,5	8,5	8,5	8,5	8,5	14,5	17,0	17,0	17,0	17,0
Global warming potential (GWP)		2088	2088	2088	2088	2088	2088	2088	2088	2088	2088	2088	2088
Equivalent CO ₂ charge	t	13,57	13,57	13,57	17,74	17,74	17,74	17,74	30,27	35,49	35,49	35,49	35,49
Water tank volume	l	100	100	100	100	100	100	300	300	300	500	500	500

Units only available for the non-EU market

SA/LS/CO		1602	1802	2002	2302	2502	2504	3004	3204	3504	4004	4504	5004
Cooling capacity (EN14511) ⁽¹⁾	kW	121,7	139,1	153,0	182,3	205,3	200,4	220,2	244,6	296,6	326,6	366,7	414,0
Total input power (EN14511) ⁽¹⁾	kW	44,6	50,6	58,8	64,9	73,6	72,3	83,4	92,3	101,2	115,4	130,5	148,4
EER (EN14511) ⁽¹⁾	W/W	2,73	2,75	2,60	2,81	2,79	2,77	2,64	2,65	2,93	2,83	2,81	2,79
SEER ⁽²⁾	kWh/kWh	3,83	3,91	3,90	3,90	3,81	3,80	3,80	3,80	3,81	3,80	3,82	4,10
η _{s,c} ⁽²⁾	%	150	153	153	153	149	149	149	149	149	149	150	161
Sound power ⁽³⁾	dB (A)	86	86	86	89	90	87	89	90	90	91	92	93
Sound pressure ⁽⁴⁾	dB (A)	54	54	54	57	58	55	57	58	58	59	60	61
Water tank volume	l	500	500	500	500	500	500	500	500	1000	1000	1000	1000
SE/LS/CO		1602	1802	2002	2302	2502	2504	3004	3204	3504	4004	4504	5004
Cooling capacity (EN14511) ⁽¹⁾	kW	122,5	140,2	154,4	183,3	207,1	201,7	221,8	246,2	297,1	327,8	370,6	417,1
Total input power (EN14511) ⁽¹⁾	kW	44,2	50,3	58,0	64,5	72,9	71,5	82,5	91,2	100,0	115,0	129,6	146,9
EER (EN14511) ⁽¹⁾	W/W	2,77	2,79	2,66	2,84	2,84	2,82	2,69	2,70	2,97	2,85	2,86	2,84
SEER ⁽²⁾	kWh/kWh	3,95	4,00	4,01	4,01	4,01	3,96	3,97	3,98	4,04	4,00	4,01	4,25
η _{s,c} ⁽²⁾	%	155	157	157	157	157	155	156	156	159	157	157	167
Sound power ⁽³⁾	dB (A)	87	87	87	93	90	87	89	90	93	95	96	96
Sound pressure ⁽⁴⁾	dB (A)	55	55	55	61	58	55	57	58	61	63	64	64
Power supply	V/Ph/Hz	400/3/50	400/3/50	400/3/50	400/3/50	400/3/50	400/3/50	400/3/50	400/3/50	400/3/50	400/3/50	400/3/50	400/3/50
Compressors / Circuits	n° / n°	2 / 1	2 / 1	2 / 1	2 / 1	2 / 1	4 / 2	4 / 2	4 / 2	4 / 2	4 / 2	4 / 2	4 / 2
Fans	n°	4	4	4	3	4	4	4	4	6	6	6	8
Refrigerant		R410A	R410A	R410A	R410A	R410A	R410A	R410A	R410A	R410A	R410A	R410A	R410A
Refrigerant charge	kg	18,0	30,0	25,0	33,0	33,0	40,0	40,0	50,0	60,0	70,0	90,0	90,0
Global warming potential (GWP)		2088	2088	2088	2088	2088	2088	2088	2088	2088	2088	2088	2088
Equivalent CO ₂ charge	t	37,58	62,64	52,20	69,90	69,90	83,52	83,52	104,40	152,28	146,16	187,92	187,92
Water tank volume	l	500	500	500	500	500	500	500	500	1000	1000	1000	1000

Performances are referred to the following conditions:

- (1) Cooling: ambient air temperature 35°C, evaporator water temperature in/out 12/7 °C.
- (2) In accordance with (EU) 2016/2281 and relative norms part of this.

(3) Sound power level in accordance with ISO 3744.

(4) Sound pressure level at 10 mt from the unit in free field conditions in accordance with ISO 3744.

Units only available for the non-EU market

SA/XL/CO		252	302	402	432	492	592	702	802	902	1002	1202	1402
Cooling capacity (EN14511) ⁽¹⁾	kW	18,8	25,5	29,5	39,7	44,3	50,4	55,8	63,0	71,1	85,2	92,7	105,2
Total input power (EN14511) ⁽¹⁾	kW	6,7	9,2	11,0	14,1	15,3	18,6	21,3	23,1	28,3	31,4	36,8	41,1
EER (EN14511) ⁽¹⁾	W/W	2,80	2,76	2,67	2,82	2,89	2,71	2,62	2,73	2,51	2,71	2,52	2,56
SEER ⁽²⁾	kWh/kWh	3,80	3,85	3,87	3,83	3,82	3,90	3,83	3,84	3,80	3,90	3,81	3,92
$\eta_{s,c}$ ⁽²⁾	%	149	151	152	150	150	153	150	151	149	153	149	154
Sound power ⁽³⁾	dB (A)	71	71	71	71	75	75	75	76	77	80	82	83
Sound pressure ⁽⁴⁾	dB (A)	39	39	39	39	43	43	43	44	45	48	50	51
Water tank volume	l	100	100	100	100	100	100	300	300	300	500	500	500

SA/XL/CO		1602	1802	2002	2302	2502	2504	3004	3204	3504	4004	4504	5004
Cooling capacity (EN14511) ⁽¹⁾	kW	118,0	135,5	148,2	175,9	198,0	193,1	210,6	232,2	286,8	314,4	355,2	395,0
Total input power (EN14511) ⁽¹⁾	kW	45,7	51,9	60,0	65,6	73,3	72,3	83,9	94,0	100,6	116,4	131,6	146,3
EER (EN14511) ⁽¹⁾	W/W	2,58	2,61	2,47	2,68	2,70	2,67	2,51	2,47	2,85	2,70	2,70	2,70
SEER ⁽²⁾	kWh/kWh	3,82	3,93	3,82	3,93	3,83	3,81	3,84	3,80	3,92	3,82	3,95	3,94
$\eta_{s,c}$ ⁽²⁾	%	150	154	150	154	150	149	151	149	154	150	155	155
Sound power ⁽³⁾	dB (A)	85	85	85	87	89	85	87	88	88	88	90	91
Sound pressure ⁽⁴⁾	dB (A)	53	53	53	55	57	53	55	56	56	56	58	59
Water tank volume	l	500	500	500	500	500	500	500	500	1000	1000	1000	1000

Performances are referred to the following conditions:

(1) Cooling: ambient air temperature 35°C, evaporator water temperature in/out 12/7 °C.

(2) In accordance with (EU) 2016/2281 and relative norms part of this.

(3) Sound power level in accordance with ISO 3744.

(4) Sound pressure level at 10 mt from the unit in free field conditions in accordance with ISO 3744.

Frame

All units are made from hot-galvanised sheet steel, painted with polyurethane powder enamel and stoved at 180°C to provide maximum protection against corrosion. The frame is self-supporting with removable panels. All screws and rivets used are made from stainless steel. The standard colour of the units is RAL9018.

Refrigerant circuit

The refrigerant utilised is R410A. The refrigerant circuit is assembled using internationally recognised brand name components with all brazing and welding being performed in accordance with ISO 97/23. The refrigerant circuit includes: sight glass, filter drier, thermal expansion valve with external equalizer, Schrader valves for maintenance and control, pressure safety device (for compliance with PED regulations).

Compressors

The compressors used are a high performance scroll type. In all units the compressors are connected in tandem. This results in much higher efficiencies at part loads compared to units with independent refrigerant circuits.

The compressors are all supplied with a crankcase heater and thermal overload protection by a klixon embedded in the motor winding. They are mounted in a separate enclosure in order to be separated from the air stream thus enabling them to be maintained even if the unit is operating. Access to this enclosure is by the front panel of the unit. The crankcase heater is always powered when the compressor is in stand-by.

Source heat exchanger

The source heat exchanger is made from copper pipes and aluminium fins. Dimensioning of the copper pipes and the aluminium fins is optimized in order to obtain excellent performance.

The tubes are mechanically expanded into the fins in order to maximise heat transfer. Furthermore, the design guarantees a low air side pressure drop thus enabling the use of low rotation speed (and hence low noise) fans. All heat exchangers are supplied standard with fins hydrophilic coating.

User heat exchangers

The user heat exchanger is a braze welded, plate type heat exchanger, manufactured from AISI 316 stainless steel. The use of this type of exchanger results in a massive reduction of the refrigerant charge of the unit compared to a traditional shell-in-tube type. A further advantage is a reduction in the overall dimensions of the unit.

The exchangers are factory insulated with flexible close cell material and can be fitted with an antifreeze heater (accessory). Each exchanger is fitted with a temperature sensor on the discharge water side for antifreeze protection.

Fans

The fans are direct drive axial type with aluminium aerofoil blades, are statically and dynamically balanced and are supplied complete with a safety fan guard complying with the requirements of EN 60335.

They are fixed to the unit frame via rubber anti-vibration mountings. The electric motors, in LS versions are 6 poles type rotating at approximately 900 rpm. In the XL versions the fans are 8 poles type (approx 600 rpm). The motors are fitted with integrated thermal overload protection and have a moisture protection rating of IP 54.

Microprocessors

All units are supplied as standard complete with control panel.

The microprocessor controls the following functions: control of the water temperature, antifreeze protection, compressor timing, compressor automatic starting sequence, alarm reset, volt free contact for remote general alarm, alarms and operation LED's. If required (available as an option), the microprocessor can be configured in order for it to connect to a site BMS system thus enabling remote control and management. The Hidros technical department can discuss and evaluate, in conjunction with the customer, solutions using MODBUS protocols.

Electric enclosure

The enclosure is manufactured in order to comply with the requirements of the electromagnetic compatibility standards CEE EN60204. Access to the enclosure is quick and easy thanks to hin-

ged panels. The following components are supplied as standard on all units: main switch, a sequence relay that disables the power supply in the event that the phase sequence is incorrect (scroll compressors can be damaged if they rotate in the wrong direction), thermal overloads (protection of pumps and fans), compressor fuses, control circuit automatic breakers, compressor contactors, fan contactors and pump contactors. The terminal board has volt free contacts for remote ON-OFF, Summer/ winter change over (heat pumps only) and general alarm.

Control and protection devices

All units are supplied with the following control and protection devices: Return water temperature sensor installed on the return water line from the building, antifreeze protection sensor installed on the outlet water temperature, high pressure switch with manual reset, low pressure switch with automatic reset, high pressure safety valve, compressor thermal overload protection, fans thermal overload protection and flow switch.

Versions

CO Version

Cooling only version, chilled water available down to a minimum temperature of 4°C.

BT Version

Low user water temperature; supplied with a specific cooling circuit allowing the unit to operate with user chilled water between +4°C and -5°C.

SA Version

Standard efficiency version, for the non-EU market. Unit equipped with AC fans.

SE Version

Standard efficiency version, according to current standard. Unit equipped with EC fans.

HA Version

High efficiency version, according to current standard. Unit equipped with AC fans.

HE Version

High efficiency version, according to current standard. Unit equipped with EC fans.

LS Version

This version includes the complete acoustic insulation of the unit with compressor jackets and insulating material made with high density media and the interposition of heavy bitumen layer.





XL Version

Units in XL version are supplied, as standard, with the latest 'Floating Frame' technology that completely isolates the compressors from the main casing, thereby eliminating vibration and noise from this source. The 'Floating Frame' is a special vibration and acoustic damping system that consists of a base plate and acoustic enclosure that houses the compressors. The base plate is separated from the supporting frame of the unit by soft steel springs that have a high damping power. Within the enclosure, the compressors are mounted on rubber shock absorbers on the floating base plate. The enclosure is manufactured from galvanized steel sandwich panels that have a micro-perforated inner skin and a core of 30 mm thick, high density (25 kg/m³). The entire arrangement provides a double damping system and acoustic attenuation. The compressor refrigerant pipes are connected to the refrigerant circuit through "anaconda" flexible connections. Flexible connections are also used on the water pipework within the unit. The combination of these systems results in an overall noise reduction in the region of 6–8 dB(A).

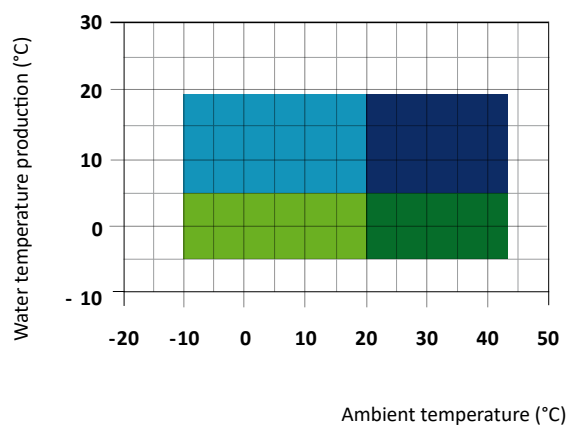
Unit equipped with low rotation speed fans (approx. 600 rpm).

Operation Limits



-  Cooling mode with cond. press. contr.
-  Cooling mode without cond. press. contr.
-  Cooling mode with cond. press. contr. and glycol (Only BT versions)
-  Cooling mode without cond. press. contr. and glycol (Only BT versions)

Floating frame - XL Version

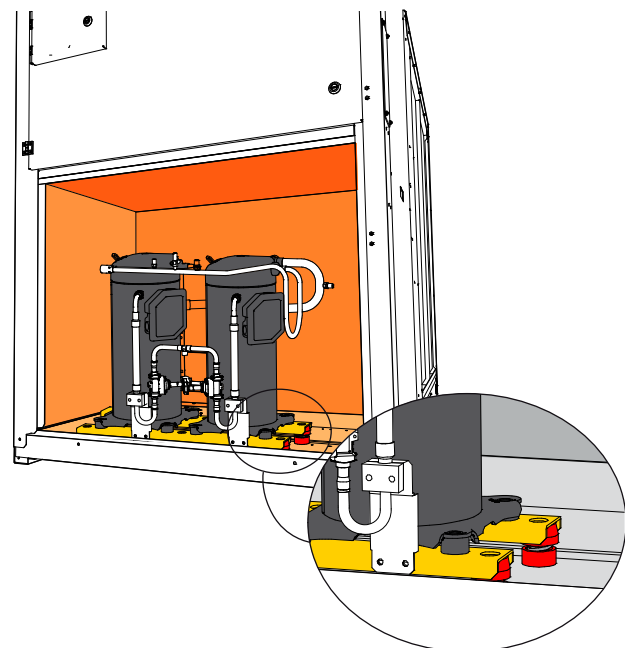

LDA		242	252	292	302	402	412	432	492	592	602	702	802
Flow switch		●	●	●	●	●	●	●	●	●	●	●	●
"Floating frame" Technology - LS Version		-	-	-	-	-	-	-	-	-	-	-	-
"Floating frame" Technology - XL Version		●	●	●	●	●	●	●	●	●	●	●	●
E.C. fans - SE versions	VECE	●	●	●	●	●	●	●	●	●	●	●	●
A.C. fans - HA versions	VECE	-	-	-	-	-	-	-	-	-	-	-	-
E.C. fans - HE versions	VECE	●	●	●	●	●	●	●	●	●	●	●	●
Evap/cond. press. control by transducer and fan speed control	DCCF	○	○	○	○	○	○	○	○	○	○	○	○
Antifreeze kit for 2 pipe units	RAEV2	○	○	○	○	○	○	○	○	○	○	○	○
Electronic soft starter	DSSE	○	○	○	○	○	○	○	○	○	○	○	○
Serial interface card RS485	INSE	○	○	○	○	○	○	○	○	○	○	○	○
Rubber anti-vibration mountings	KAVG	○	○	○	○	○	○	○	○	○	○	○	○
Remote control panel	PCRL	○	○	○	○	○	○	○	○	○	○	○	○
Electronic expansion valve	VTEE	○	○	○	○	○	○	○	○	○	○	○	○
Cascade control system via RS485	SGRS	○	○	○	○	○	○	○	○	○	○	○	○
Hydraulic kit with one pump with tank	A1ZZU	○	○	○	○	○	○	○	○	○	○	○	○
Hydraulic kit with two pumps with tank	A2ZZU	○	○	○	○	○	○	○	○	○	○	○	○
Hydraulic kit with one pump without tank	A1NTU	○	○	○	○	○	○	○	○	○	○	○	○
Hydraulic kit with two pumps without tank	A2NTU	○	○	○	○	○	○	○	○	○	○	○	○

● Standard ○ Optional – Not available

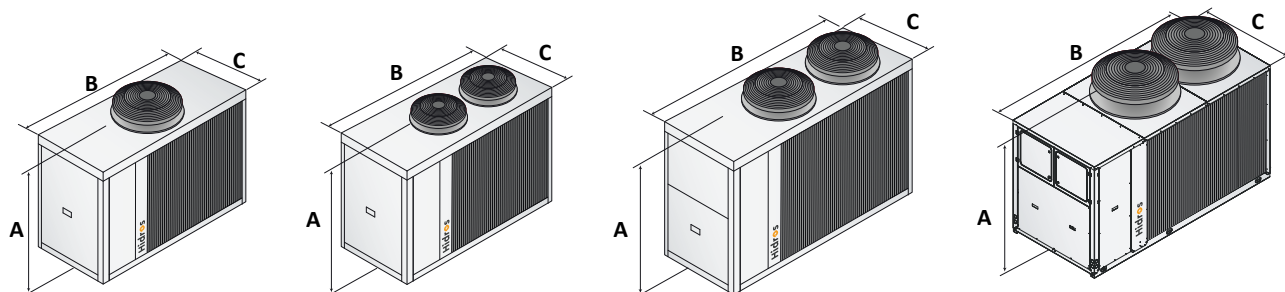

SA/SE LS 242 - 292
HA/HE LS 242 - 292

SA XL 252 - 302 - 402
HA/HE XL 252 - 302

SA/SE-LS/XL 432 - 492 - 592
HA/HE-LS/XL 412 - 432 - 492

SA/SE-LS/XL 702 - 802 - 902
HA/HE-LS/XL 602 - 702 - 802 - 902
- 1002 - 1202

		242/252	292/302	402	412	432	492	592	602	702	802
A	SA-SE/LS	1500	1500	1500	--	1690	1690	1690	--	1880	1880
B	SA-SE/LS	1915	1915	1915	--	2400	2400	2400	--	2905	2905
C	SA-SE/LS	875	875	875	--	1150	1150	1150	--	1150	1150
kg	SA-SE/LS	550	550	560	--	670	700	760	--	880	890
A	SA-SE/XL	1500	1500	1500	--	1690	1690	1690	--	1880	1880
B	SA-SE/XL	1915	1915	1915	--	2400	2400	2400	--	2905	2905
C	SA-SE/XL	875	875	875	--	1150	1150	1150	--	1150	1150
kg	SA-SE/XL	550	550	560	--	670	700	760	--	880	890
A	HA-HE/LS	1500	1500	--	1690	1690	1690	--	1880	1880	1880
B	HA-HE/LS	1915	1915	--	2400	2400	2400	--	2905	2905	2905
C	HA-HE/LS	875	875	--	1150	1150	1150	--	1150	1150	1150
kg	HA-HE/LS	560	560	--	670	690	720	--	1040	1060	1070
A	HA-HE/XL	1500	1500	--	1690	1690	1690	--	1880	1880	1880
B	HA-HE/XL	1915	1915	--	2400	2400	2400	--	2905	2905	2905
C	HA-HE/XL	875	875	--	1145	1145	1145	--	1150	1150	1150
kg	HA-HE/XL	570	570	--	680	710	740	--	1060	1080	1090

LDA		902	1002	1202	1402	1602	1802	2002	2302
Flow switch		●	●	●	●	●	●	●	●
“Floating frame” Technology - LS Version		-	-	-	-	-	-	-	-
“Floating frame” Technology - XL Version		●	●	●	●	●	●	●	●
E.C. fans - SA versions	VECE	-	-	-	-	-	-	-	-
E.C. fans - SE versions	VECE	●	●	●	●	●	●	●	●
E.C. fans - HA versions	VECE	-	-	-	-	-	-	-	-
E.C. fans - HE versions	VECE	●	●	●	●	●	●	●	●
Evap/cond. press. control by transducer and fan speed control	DCCF	○	○	○	○	○	○	○	○
Antifreeze kit for 2 pipe units	RAEV2	○	○	○	○	○	○	○	○
Electronic soft starter	DSSE	○	○	○	○	○	○	○	○
Serial interface card RS485	INSE	○	○	○	○	○	○	○	○
Rubber anti-vibration mountings	KAVG	○	○	○	○	○	○	○	○
Remote control panel	PCRL	○	○	○	○	○	○	○	○
Electronic expansion valve	VTEE	○	○	○	○	○	○	○	○
Cascade control system via RS485	SGRS	○	○	○	○	○	○	○	○
Hydraulic kit with one pump with tank	A1ZZU	○	○	○	○	○	○	○	○
Hydraulic kit with two pumps with tank	A2ZZU	○	○	○	○	○	○	○	○
Hydraulic kit with one pump without tank	A1NTU	○	○	○	○	○	○	○	○
Hydraulic kit with two pumps without tank	A2NTU	○	○	○	○	○	○	○	○

● Standard ○ Optional – Not available

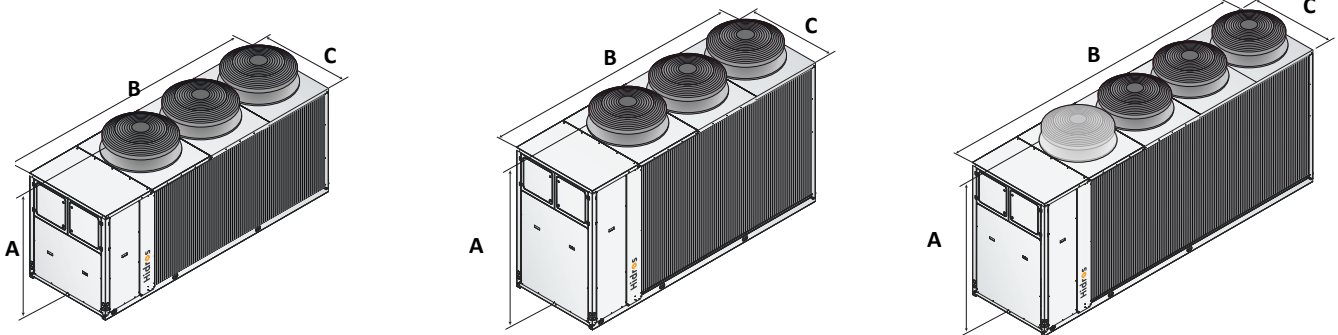

SA/SE-LS/XL 1002 - 1202 - 1402 - 1602
HA/HE-LS/XL 1402 - 1602 - 1802 - 2002

SA/SE-LS/XL 1802 - 2002
HA/HE-LS/XL 2302 - 2502

SA/SE-LS/XL 2302 - 2502

		902	1002	1202	1402	1602	1802	2002	2302
A	SA-SE/LS	1880	1880	1880	1880	1880	2270	2270	2310
B	SA-SE/LS	2905	3905	3905	3905	3905	3905	3905	4505
C	SA-SE/LS	1150	1150	1150	1150	1150	1150	1150	1150
kg	SA-SE/LS	890	1170	1240	1290	1330	1660	1680	1950
A	SA-SE/XL	1880	1880	1880	1880	1880	2270	2270	2310
B	SA-SE/XL	2905	3905	3905	3905	3905	3905	3905	4505
C	SA-SE/XL	1150	1150	1150	1150	1150	1150	1150	1150
kg	SA-SE/XL	890	1170	1240	1290	1330	1660	1680	1950
A	HA-HE/LS	1880	1880	1880	1880	1880	1880	1880	2270
B	HA-HE/LS	2905	2905	2905	3905	3905	3905	3905	3905
C	HA-HE/LS	1150	1150	1150	1150	1150	1150	1150	1150
kg	HA-HE/LS	1100	1140	1210	1530	1550	1570	1590	1750
A	HA-HE/XL	1880	1880	1880	1890	1890	1890	1890	2270
B	HA-HE/XL	2905	2905	2905	3905	3905	3905	3905	3905
C	HA-HE/XL	1150	1150	1150	1150	1150	1150	1150	1150
kg	HA-HE/XL	1120	1160	1230	1560	1580	1600	1620	1780

LDA		2502	2504	3004	3204	3504	4004	4504	5004
Flow switch		●	●	●	●	●	●	●	●
“Floating frame” Technology - LS Version		-	-	-	-	-	-	-	-
“Floating frame” Technology - XL Version		●	●	●	●	●	●	●	●
E.C. fans - SA versions	VECE	-	-	-	-	-	-	-	-
E.C. fans - SE versions	VECE	●	●	●	●	●	●	●	●
E.C. fans - HA versions	VECE	-	-	-	-	-	-	-	-
E.C. fans - HE versions	VECE	●	●	●	●	●	●	●	●
Evap/cond. press. control by transducer and fan speed control	DCCF	○	○	○	○	○	○	○	○
Antifreeze kit for 2 pipe units	RAEV2	○	○	○	○	○	○	○	○
Electronic soft starter	DSSE	○	○	○	○	○	○	○	○
Serial interface card RS485	INSE	○	○	○	○	○	○	○	○
Rubber anti-vibration mountings	KAVG	○	○	○	○	○	○	○	○
Remote control panel	PCRL	○	○	○	○	○	○	○	○
Electronic expansion valve	VTEE	○	○	○	○	○	○	○	○
Cascade control system via RS485	SGRS	○	○	○	○	○	○	○	○
Hydraulic kit with one pump with tank	A1ZZU	○	○	○	○	○	○	○	○
Hydraulic kit with two pumps with tank	A2ZZU	○	○	○	○	○	○	○	○
Hydraulic kit with one pump without tank	A1NTU	○	○	○	○	○	○	○	○
Hydraulic kit with two pumps without tank	A2NTU	○	○	○	○	○	○	○	○

● Standard ○ Optional – Not available

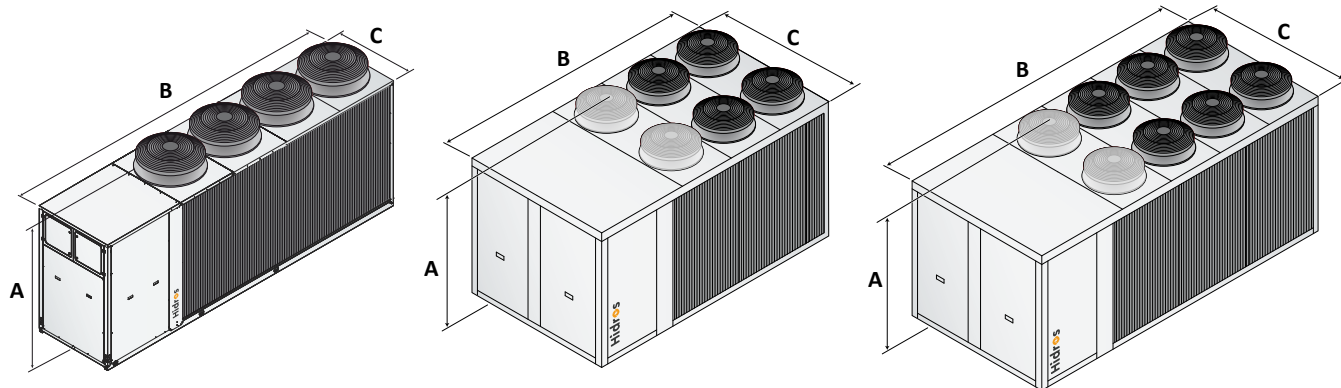

SA/SE-LS/XL 2504 - 3004 - 3204

SA/SE-LS/XL 3504 - 4004
HA/HE-LS/XL 2504 - 3004 - 3204 - 3504

SA/SE-LS/XL 4504 - 5004
HA/HE-LS/XL 4004 - 4504 - 5004

		2502	2504	3004	3204	3504	4004	4504	5004
A	SA-SE/LS	2310	2310	2310	2310	2350	2350	2380	2380
B	SA-SE/LS	4505	5300	5300	5300	4205	4205	5250	5250
C	SA-SE/LS	1150	1150	1150	1150	2210	2210	2210	2210
kg	SA-SE/LS	2000	2460	2500	2580	3170	3220	3550	3650
A	SA-SE/XL	2310	2310	2310	2310	2350	2350	2380	2380
B	SA-SE/XL	4505	5300	5300	5300	4205	4205	5250	5250
C	SA-SE/XL	1150	1150	1150	1150	2210	2210	2210	2210
kg	SA-SE/XL	2000	2460	2500	2580	3170	3220	3550	3650
A	HA-HE/LS	2270	2350	2350	2350	2350	2380	2380	2380
B	HA-HE/LS	3905	4205	4205	4205	4205	4805	5250	5250
C	HA-HE/LS	1150	2210	2210	2210	2210	2210	2210	2210
kg	HA-HE/LS	1780	3120	3170	3220	3270	3610	3670	3720
A	HA-HE/XL	2270	2350	2350	2350	2350	2380	2380	2380
B	HA-HE/XL	3905	4205	4205	4205	4205	4805	5250	5250
C	HA-HE/XL	1150	2210	2210	2210	2210	2210	2210	2210
kg	HA-HE/XL	1810	3170	3220	3270	3320	3660	3720	3770