

HMA

Industrial dehumidifiers



HMA dehumidifiers series are high-performances units especially designed for industrial or commercial purposes where humidity level should be controlled or water vapor condensation should be prevented. These units are particularly indicated for archives, ironing rooms, bookstores, cheese factories, underground rooms, cellars and industrial sites where high humidity level is present. This series comprises 6 models which cover a capacity range from 263 to 940 l/24h. HMA units are designed for easy maintenance and service, in fact, the internal parts are mainly located in a soundproofed technical compartment, easily accessible even if the unit is running.

The units are supplied with a solenoid valves set for the hot gas injection used to defrost the evaporator in case of severe working conditions.

The units are equipped with an advanced microprocessor with preparation for RS485 connection (optional).

Temperature and humidity probes are accessories supplied on request.

Versions

The series includes 6 models with air flows from 3500 to 8500 m³/h.

HMA		270	350	450	550	750	950
Moisture removed at 30°C - 80%	l/24h	263,1	340,2	418,8	566,8	751,1	939,3
Moisture removed at 30°C - 60%	l/24h	185,1	262,3	336,3	425,0	596,4	759,7
Moisture removed at 27°C - 60%	l/24h	161,4	233,5	302,0	375,7	534,3	680,3
Moisture removed at 20°C - 60%	l/24h	111,4	168,5	223,9	267,1	391,0	501,0
Moisture removed at 10°C - 70%	l/24h	75,6	118,3	160,9	180,2	269,8	349,6
Nominal input power at 30°C - 80%	kW	4,09	5,40	8,33	9,38	13,9	18,39
Maximum input power	kW	6,3	7,7	9,6	12,6	17,5	20,7
Maximum input current	A	10,4	12,8	17,0	19,4	27,2	34,8
Peak current	A	56,0	58,0	76,0	87,0	108,0	150,0
Air Flow	m ³ /h	3500	4200	4200	5500	7000	8500
Available static pressure	Pa	50÷150	50÷150	50÷150	50÷150	50÷150	50÷150
Refrigerant		R410a	R410a	R410a	R410a	R410a	R410a
Global warming potential (GWP)		2088	2088	2088	2088	2088	2088
Refrigerant charge	kg	3,0	2,5	2,5	6,3	6,6	7,0
Equivalent CO ₂ charge	t	6,26	5,22	5,22	13,15	13,78	14,61
Sound power ⁽¹⁾	dB(A)	70	71	71	73	73	73
Sound pressure ⁽²⁾	dB(A)	63	64	64	66	66	66
Power supply	V/Ph/Hz	400/3+N/50	400/3+N/50	400/3+N/50	400/3+N/50	400/3+N/50	400/3+N/50

Performances are calculated with low fan speed and are referred to the following conditions:
(1)Sound Power level according to ISO 9614 fan with available static pressure 50 Pa.

(2)Sound Pressure level measured at 1 mt from the unit in free field conditions according with ISO 9614, fan with available static pressure 50 Pa.

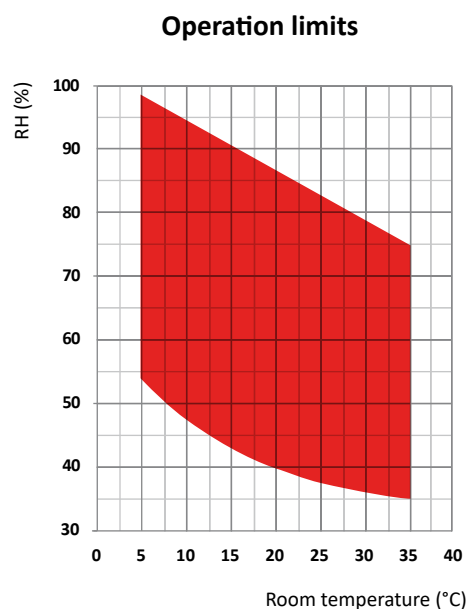
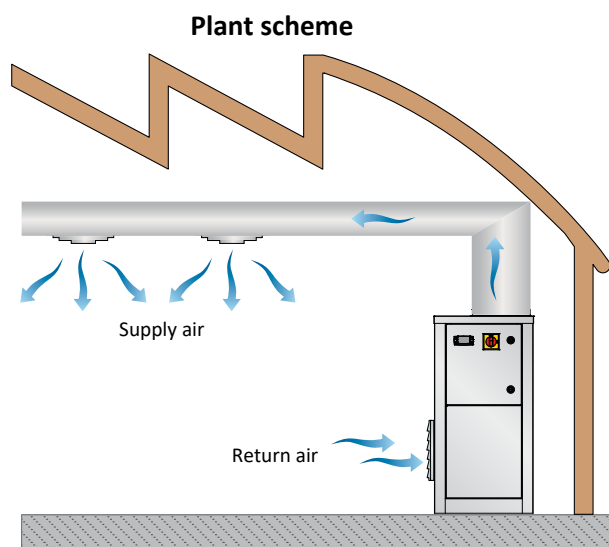

Frame

All units are made from hot-galvanised thick sheet metal, painted with polyurethane powder enamel at 180°C to ensure the best resistance against the atmospheric agents. The frame is self-supporting with removable panels. All screws and rivets are in stainless steel. The colour of the units is RAL 9018.

Refrigerant circuit

The refrigerant gas used in these units is R410A. The refrigerant circuit is made by using international primary brands components and according to ISO 97/23 concerning welding procedures. The refrigerant circuit includes: sight glass, filter drier, thermal expansion valve with external equalizer, Schrader valves for maintenance and control, pressure safety device (according to PED regulation). All the units are supplied with injection valves kit for hot gas defrost cycle.

Compressor

The compressors are Scroll type, with thermal overload protection by a klixon embedded in the motor winding. The compressor is mounted on rubber vibration dampers and it is supplied, standard, installed in a dedicated technical compartment to reduce noise emission. The inspection is possible through the frontal panel of the unit that allows the maintenance of the compressor.

Condenser and evaporator

Condensers and evaporators are made of copper pipes and aluminium fins.

The diameter of the copper pipes is 3/8" and the thickness of the aluminium fins is 0,1 mm. The tubes are mechanically expanded into the aluminium fins to improve the heat exchange factor. The geometry of these heat exchangers guarantees a low air side pressure drop and then the use of low rotation (and low noise emission) fans.

All units are supplied, standard, with a powder coated steel drip tray and all evaporators are supplied with a temperature sensor used as automatic defrost probe.

Fan

The fans are made of galvanized steel, centrifugal type. It is statically and dynamically balanced and supplied.

The electric motors are directly connected to the fan; they are all at 2 speeds, with integrated thermal protection. The protection class of the motors is IP 54.

Air filter

It is made of synthetic filtering media, pleated type, without electro-static charge; they are all removable for differential disposal, ePM10 50% according to UNI EN ISO 16890:2017.

Microprocessor

All units are supplied standard with microprocessor controls. The microprocessor controls the following functions: compressor timing, automatic defrost cycles, alarms.

An appropriate LCD display shows the operation mode of the unit, set point and alarms.

Electric box

The electric switch board is made according to electromagnetic compatibility norms CEE 2014/35 and 2014/30. The accessibility to the board is possible after removing the front panel of the unit and the OFF positioning of the main switch. The following components are also standard installed: main switch, magnetic-thermal

switches (as a protection fans and compressors), control circuit automatic breakers, compressor contactors, fan contactors. The terminal board is supplied with voltage free contacts for remote ON-OFF and general alarm.

Control and protection devices

All units are supplied with the following control and protection devices: antifreeze protection sensor, high pressure switch with manual reset, low pressure switch with automatic reset, high pressure safety valve, compressor thermal overload protection, fans thermal overload protection.

Test

All the units are fully assembled and wired at the factory, carefully evacuated and dried after leak tests under pressure and then charged with refrigerant R410A.

They are all fully operational tested before shipment. They all conform to European Directives and are individually marked with the CE label and provided with Conformity Declaration.

Accessories

CANA - Delivery flange for channel connection

Press-folded rectangular flange for connection to the ducts and installed on the fan expulsion mouth.

FARC - Air filter with frame for ducted installation

Complete with efficiency class air filter which can be removed by the side and frame for ducted installation.

HYGR - Remote mechanical hygromat

To be installed on the wall, it is supplied with a regulation knob and working range from 30% to 100% with precision of 3%.

INOX - Stainless steel frame

It's used to ensure the best resistance against the atmospheric agents and the operation in aggressive environments. The frame is made of stainless steel AISI 304, self-supporting with removable panels to facilitate inspection and maintenance of internal components. All screws and rivets are in stainless steel.

INSE - Serial interface card RS485

This interface card enables the controller to communicate with other devices using Modbus protocol.

KAVG - Rubber vibration dampers

To be installed beneath the unit base and the ground to avoid the transmission of vibrations (and the noise) to the building.

LS00 - Low noise version

This version includes the complete acoustic insulation of the unit (compressor + heat exchangers vanes) with compressor jackets and insulating material made with high density media and the interposition of heavy bitumen layer.

PCRL - Remote control panel

This panel can be mounted up to 50m (maximum) from the unit and replicates all of the control functions. It is connected using a twin cable of 0.5 mm sq section.

RGDD - Humidity and Temperature electronic probe sensor

Built-in Electronic temperature and humidity probe.

TROL - Floor trolley version

To facilitate dehumidifier handling where is placed.

V1CE - E.C. supply fan

The supply fan is a high performance centrifugal type, double inlet forward curved blades, directly coupled to the electric motor. The fan wheel and the scroll are made from hot galvanised thick sheet metal, painted with polyurethane powders, to ensure the best re-

sistance against aggressive environments.

The electric motor is a high efficiency DC brushless type with external rotor, to guarantee an ideal cooling of the windings and the absence of power lost due to pulleys and belt transmission. The fan is statically and dynamically balanced class 6,3 according to ISO1940. The electric motor has a separate electronic commutator (driver) and a speed modulation 0-10V, integrated PFC, burn out thermal protection (in case of considerable reduction of the power supply), protection degree IP54, serial interface card with modbus protocol RTU.

HMA		270	350	450	550	750	950
A.C. fans ≤ 150 Pa		●	●	●	●	●	●
Supply flange	CANA	●	●	●	●	●	●
Hot gas defrost		●	●	●	●	●	●
Thermostatic valve		●	●	●	●	●	●
Low noise version	LS00	●	●	●	●	●	●
Main switch		●	●	●	●	●	●
Rubber vibration dampers	KAVG	○	○	○	○	○	○
Remote mechanical hygostat	HYGR	○	○	○	○	○	○
Floor trolley version	TROL	○	○	○	○	○	○
Stainless steel frame	INOX	○	○	○	○	○	○
Air filter with frame for ducted installation	FARC	○	○	○	○	○	○
Humidity and Temperature electronic probe sensor	RGDD	○	○	○	○	○	○
Remote control Panel	PCRL	○	○	○	○	○	○
High efficiency E.C. fans ≤ 300 Pa	V1CE	○	○	○	○	○	○
Serial interface card RS485	INSE	○	○	○	○	○	○

● Standard, ○ Optional, – Not available.

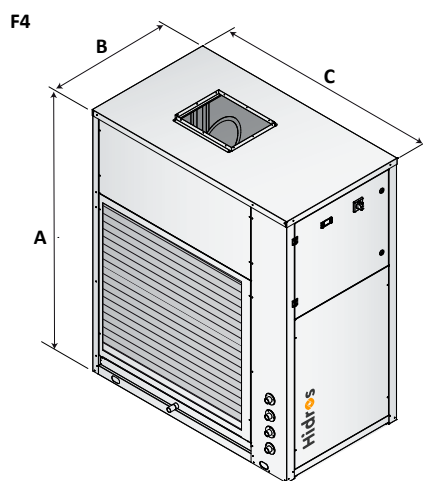
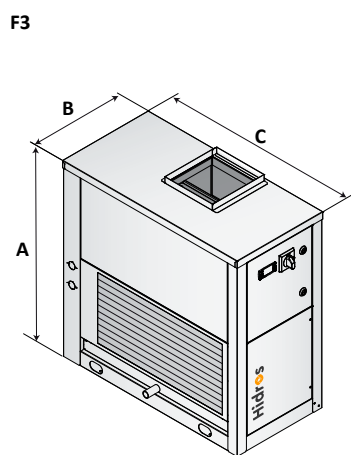

Configurations

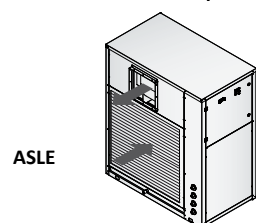
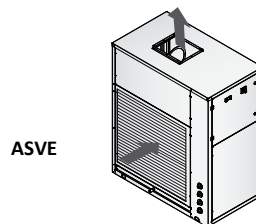
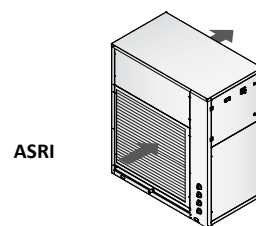

Mod.	Frame	A (mm)	B (mm)	C (mm)	kg
270	F3	1378	704	1154	207
350	F3	1378	704	1154	211
450	F3	1378	704	1154	215
550	F4	1750	854	1504	415
750	F4	1750	854	1504	423
950	F4	1750	854	1504	430