

FH - GH

Dehumidifiers for radiant cooling systems

FH



GH



The dehumidifiers FH and GH series are high performance units, equipped with robust galvanised steel frame, properly designed to operate in combination with radiant cooling systems. The FH units have been designed for wall mounting installation while the GH series are suitable for false ceiling and ducted applications. All units are provided with air filter, stainless steel drip tray and built-in microprocessor control. The units are also provided, standard, with pre and post cooling coil to enhance the performances and to control the air supply temperature. FH and GH units, anyway, can operate even without pre and post cooling coils, this option could be very useful in middle seasons when it is necessary to dry but the air conditioning system is not in operation. All the units are fully assembled and wired in the factory, carefully evacuated and dried with after leak tests under pressure and they are charged with environmental friendly refrigerant gases. They are fully tested before shipment; the units are conform to European Directives and are individually marked with CE label and Conformity Declaration.

Versions

- WZ** Units supplied with double condenser (the first is an air condenser, the second is a water one) and of a logic which allows the dehumidification with neutrum air or with cooled air.

FH - FHWZ		25	25WZ
Moisture removed ⁽¹⁾	l/24h	20,1	20,1
Cooling capacity ⁽¹⁾	W	---	1250
Total power input ⁽¹⁾	W	360	360
Max power input	W	440	440
Max input current	A	2,7	2,7
Peak current	A	18,1	18,1
Air flow	m ³ /h	250	250
Refrigerant		R134a	R134a
Global warming potential (GWP)		1430	1430
Refrigerant charge	kg	0,2	0,6
Equivalent CO ₂ charge	t	0,36	0,89
Water flow	l/h	150	150
Pressure drop	kPa	8	7,8
Sound power ⁽²⁾	dB(A)	45	45
Sound pressure ⁽³⁾	dB(A)	37	37
Power supply	V/Ph/Hz	230/1/50	230/1/50

GH - GHWZ		25	25WZ	50	50WZ	100	100WZ	200	200WZ
Moisture removed ⁽¹⁾	l/24h	20,1	20,1	48,5	48,5	87,2	87,2	164,0	164,0
Cooling capacity ⁽¹⁾	W	---	1250	---	3500	---	6000	---	11300
Total power input ⁽¹⁾	W	340	340	700	700	1450	1450	2450	2450
Max power input	W	420	420	830	830	1690	1690	2890	2890
Max input current	A	2,7	2,7	5,0	5,0	8,1	8,1	14,4	14,4
Peak current	A	18,1	18,1	20,7	20,7	35,9	35,9	63,0	63,0
Water flow	l/h	150	150	500	500	600	600	900	900
Pressure drop	kPa	8,0	7,8	17,0	42,0	32,0	39,5	48,0	64,0
Air flow	m ³ /h	250	250	600	600	1000	1000	1850	1850
Available static pressure (max. speed)	Pa	43	43	60	60	75	75	120	120
Refrigerant		R134a	R134a	R407C	R407C	R407C	R407C	R407C	R407C
Global warming potential (GWP)		1430	1430	1774	1774	1774	1774	1774	1774
Refrigerant charge	kg	0,2	0,6	0,7	0,9	1,0	1,6	1,7	2,0
Equivalent CO ₂ charge	t	0,36	0,89	1,24	1,57	1,77	2,79	3,02	3,55
Sound power ⁽²⁾	dB(A)	45	45	50	50	57	57	64	64
Sound pressure ⁽³⁾	dB(A)	37	37	42	42	49	49	56	56
Power supply	V/Ph/Hz	230/1/50	230/1/50	230/1/50	230/1/50	230/1/50	230/1/50	230/1/50	230/1/50

Performances are referred to the following conditions:

(1)Room temperature 26°C; relative humidity 65% with cold water coil water inlet temp. 15°C.

(3)Sound power level in accordance with ISO 9614.

(2)Sound pressure level measured at 1 mt from the unit in free field conditions according to ISO 9614, minimum fan speed.(Only for FH versions)

Frame

All units FH-GH series are made from hot-galvanised thick sheet metal, to ensure the best resistance against the corrossions. The frame is self-supporting with removable panels. The drip tray is present standard in all units and is made of plastic material for model 25 and in metal material for models 50-100-200.

Refrigerant circuit

The refrigerant circuit is made by using international primary brands components and according to ISO 97/23 concerning welding procedures. The refrigerant gas used in these units is R134a for the model 25 and R407C for the models 50-100-200.

The refrigerant circuit includes: filter drier, capillary expansion device, Schrader valves for maintenance and control, pressure safety device (according to PED regulation).

Compressor

The compressor (for model 25) is alternative or rotative type (for models 50-100-200), equipped with crankcase heater and thermal overload protection by a klixon embedded in the motor winding. It's mounted on rubber vibration dampers to reduce the noise.

Condenser and evaporator

The condensers and evaporators are made of copper pipes and aluminium fins. The diameter of the copper pipes is 3/8" and the thickness of the aluminium fins is 0,1 mm. The tubes are mechanically expanded into the aluminium fins to improve the heat exchange factor. The geometry of these condensers guarantees a low air side pressure drop and then the use of low rotation (and low noise emission) fans. All the units have a stainless steel drip tray. Besides this, each evaporator is supplied of a temperature probe used as automatic antifreeze probe. In all units WZ besides these exchangers, there is a third stainless steel INOX AISI 316 plate exchanger used as condenser in cooling modality, powered by the plant water.

Pre and post water cooling coils

The pre and post cold water coils are made of copper pipes and aluminium fins. The diameter of the copper pipes is 3/8" and the thickness of the aluminium fins is 0,1 mm. The tubes are mechanically expanded into the aluminium fins to improve the heat exchange factor. The pre-cooling coil is used to increase the dehumidification capacity of the unit, while the post-cooling coil is used to keep the outlet air temperature at the same inlet value. In WZ version only the pre cooled water coil is present.

Fan

The supply fan is centrifugal type, double inlet with forwards blades, dynamically and statically balanced and directly connected to a 3 speed fan motor.

Air filter

For the model GH 25-50 it's supplied standard with the unit and it's built in nylon. It can be removed for differential disposal, class coarse 30%, according to UNI EN ISO 16890:2017. Regarding the model 100 and 200, it's made of filtering material in synthetic fibre without electrostatic charge. It can be removed for differential disposal and is class coarse 60% according to UNI EN ISO 16890:2017

Microprocessor

All units FH-GH are supplied standard with microprocessor controls. The microprocessor controls the following functions: compressor timing, automatic defrost cycles and alarms. An appropriate LCD display shows the operation mode of the unit, set point and alarms.

Electric box

The electric switch board is made according to electromagnetic compatibility norms CEE 2014/35 and 2014/30. The accessibility to the board is possible after removing the front panel of the unit. Ready for the connection to the power and to the consensus control, The terminal board is also supplied with voltage free contacts for remote ON-OFF. The terminal block is also built with a clean contact to allow the operation of single-mode ventilation, while the second for the cooling version (WZ). By closing the first contact, only the fan is abled to work, while the dehumidification is disabled.

Control and protection devices

All units are supplied with the following control and protection devices: defrost thermostat, which signals to the microprocessor control that a defrost cycle is needed and controls its termination (only for GH100-100WZ and GH200-200WZ).

Water temperature sensor, that signals to the microprocessor the eventual overcome of the hot water temperature set point in the pre and post water coils during operation. In this condition the compressor is disconnected while the fan always run and, when the water temperature returns within the operation limits, restarts the compressor.

The water sensor stops the compressor when the water temperature is above 35°C. The eventual use of the dehumidifier as heating device during winter season requires an additional remote thermostat with seasonal change over (not supplied). In the all WZ version, it's also supplied a high pressure switch which disable the unit operation when the limit is overcome.

Test

All the units are fully assembled and wired at the factory, carefully evacuated and dried after leak tests under pressure and then charged with ecologic refrigerant.

They are all fully operational tested before shipment. They all conform to European Directives and are individually marked with the CE label and provided with Conformity Declaration.

FH - FHWZ		25	25WZ
Limit probe		●	●
High pressure switch		–	●
Galvanized steel template	CTFH	○	○
Wood return and supply grill	GRFH	○	○
Remote mechanical hygostat	HYGR	○	–
Remote mechanical hygostat + thermostat	HYGR	–	○

● Standard, ○ Optional, – Not available.

GH - GHWZ		25	25WZ	50	50WZ	100	100WZ	200	200WZ
Limit probe		●	●	●	●	●	●	●	●
High pressure switch		–	●	–	●	–	●	–	●
Defrost thermostat		–	–	–	–	●	●	●	●
Remote mechanical hygostat	HYGR	○	–	○	–	○	–	○	–
Remote mechanical hygostat + thermostat	HYGR	–	○	–	○	–	○	–	○
Delivery and return plenum 90°	CANA	○	○	○	○	–	–	–	–

● Standard, ○ Optional, – Not available.

FH

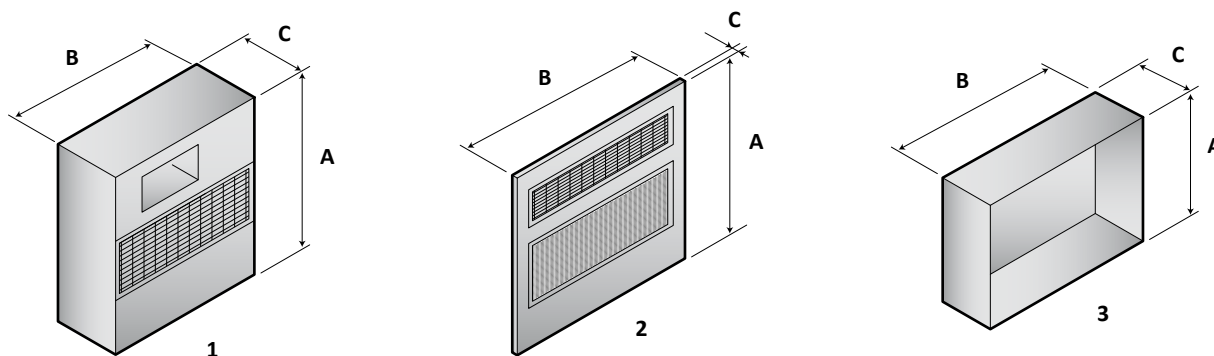

Mod.	A (mm)	B (mm)	C (mm)	kg
1	681	545	223	38/45 ⁽¹⁾
2	750	660	20	--
3	717,6	632	226,6	--

(1) WZ Version

GH

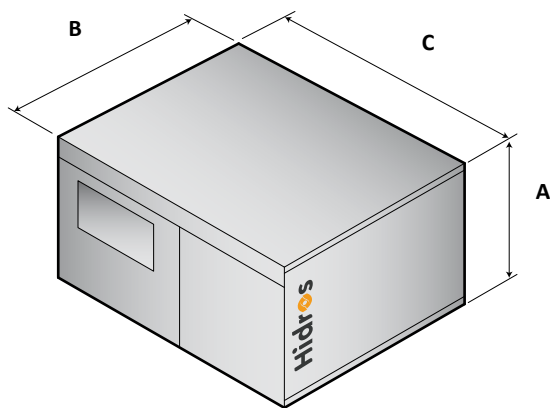

Mod.	A (mm)	B (mm)	C (mm)	kg
25	257	582	582	35
50	352	582	582	52
100	392	800	730	87
200	464	888	930	115
25WZ	257	582	582	37
50WZ	352	582	582	55
100WZ	392	800	730	90
200WZ	464	888	930	120

Refrigerant circuit standard version

The functioning of the dehumidifier model FH-GH is as follows: the fan takes the air from the ambient (7) and it's made go through the filter (1) and the pre-cooling water coil (2) where it's cooled and brought to a condition closed to saturation. Now it passes through the evaporating coil (3) where it's fatherly cooled and dehumidified. The air passes now through the condensing coil (5) where it's post heated (with a constant humidity) and in the post-cooling coil (6) where it's reported to the required conditions.

All the dehumidifiers model FH-GH can work without the help of the pre and post cooling coils. This function is very useful in case there is the request of dehumidification in middle-season or when the chiller is off. Obviously, if the unit works without the help of the cold water, the air in outlet will be hotter than the air in inlet.

Refrigerant circuit WZ version

The operation of the dehumidifier model GH is as follows: the fan takes the air from the ambient (7) and it's made go through the filter (1) and the pre-cooling water coil (2) where it's cooled and brought to a condition closed to saturation. Now it passes through the evaporating coil (3) where it's fatherly cooled and dehumidified.

At this point there are two possible modalities:

Modality with neutrum air.

The air passes now through the condensing coil (5) which allows to condensate the 50% of the total gas, (the unit condensate the 50% on air with the heat exchanger (5) and the 50% in water with the heat exchanger (10)) then there is the post-heating so that to avoid to send air in the ambient in neutrum thermic conditions.

Modality with cooled air.

The unit condensates the 100% in water through the heat –exchanger (10). The air, then, go through the condenser (5) (disabled) where does not change its characteristics (temperature and humidity).

Standard version

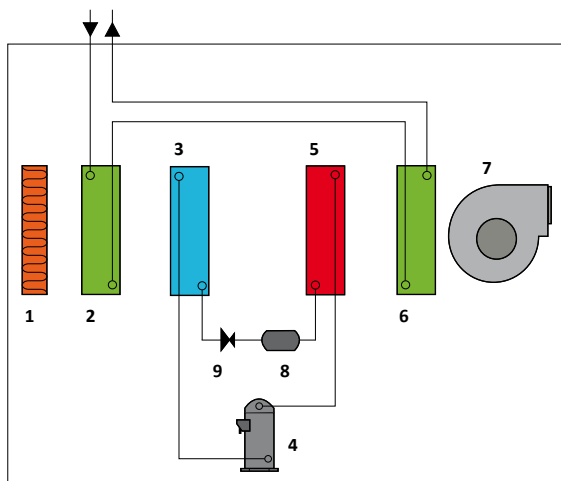

1	Air filter
2	Pre-cooling coil
3	Evaporator
4	Compressor
5	Condenser

WZ version

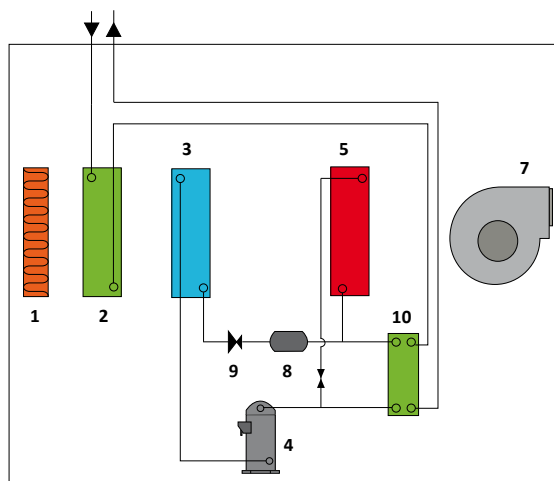

6	Post-cooling coil
7	Fan
8	Dry filter
9	Expansion device
10	Condenser water

Discharge plenum mod. GH 25 ÷ 50

GH 25

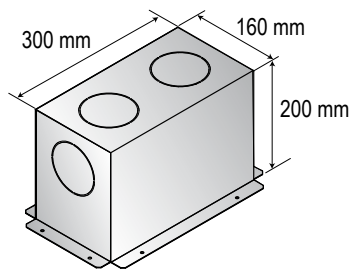

GH 50

