

LHi

High efficiency air to water heat pumps with INVERTER compressor

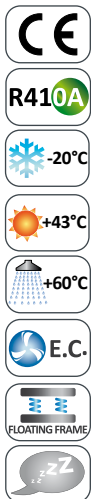
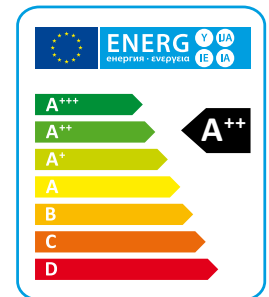

The LHi series high efficiency air/water heat pumps are particularly suitable for applications with radiant panel heating systems or for those applications where maximum efficiency in heating mode is required.

The units have been specifically designed to have the best efficiency in heating mode, they can operate up to outdoor temperatures of -20°C and produce water up to a temperature of 60°C.

All models are also equipped with reverse cycle valve for winter defrosting function; the HH versions are designed for hot water production only and are suitable for tax deductions in countries where there are specific regulations for the use of heat pumps as heat generators.

The RV versions are capable of producing chilled water.

The XL versions also have an extremely low noise level thanks to the use of a special floating vibration dampening system that allows a noise reduction of about 5-7 dB(A) (optional).

Versions

- HH** Heating only.
- RV** Reversible heating/cooling.
- SE** Standard efficiency, EC fans.
- LS** Low noise.
- XL** Super low noise.
- P2U** 2 pipe systems without domestic hot water production.
- P2S** 2 pipe systems with domestic hot water production by external 3 way valve.

Heating only version (HH)

SE/LS/HH - P2S/P2U		532	632	742	862	912	1052	1222	1534	1654	1854	1964	2254	2554
Heating capacity (EN14511) ⁽¹⁾	kW	53,3	61,8	74,2	85,1	90,9	102,5	118,3	129,0	145,3	165,2	188,7	223,4	269,6
Total input power (EN14511) ⁽¹⁾	kW	13,2	14,7	18,7	20,0	22,1	24,9	28,5	31,2	34,0	39,1	44,8	55,1	65,8
COP (EN14511) ⁽¹⁾	W/W	4,04	4,19	3,97	4,25	4,11	4,12	4,15	4,14	4,27	4,23	4,21	4,06	4,10
Energy Class ⁽²⁾		A++	A++	A++	A++	A++	A++	A++	A++	A++	A++	A++	A++	A++
SCOP ⁽²⁾	kWh/kWh	3,88	3,93	3,90	3,98	3,92	3,93	3,88	3,95	3,93	4,00	3,90	3,88	3,88
η _{s,h} ⁽²⁾	%	152	154	153	156	154	154	152	155	154	157	153	152	152
Sound power level ⁽³⁾	dB (A)	81	81	83	83	83	84	85	86	87	87	87	89	89
Sound pressure level ⁽⁴⁾	dB (A)	49	49	51	51	51	52	53	54	55	55	55	57	57
Power supply	V/Ph/Hz	400/3/50	400/3/50	400/3/50	400/3/50	400/3/50	400/3/50	400/3/50	400/3/50	400/3/50	400/3/50	400/3/50	400/3/50	400/3/50
Compressors / Circuits	n° / n°	2 / 1	2 / 1	2 / 1	2 / 1	2 / 1	2 / 1	2 / 1	4 / 2	4 / 2	4 / 2	4 / 2	4 / 2	4 / 2
Fans	n°	2	2	2	3	3	3	4	2	3	3	3	4	4
Refrigerant		R410A	R410A	R410A	R410A	R410A	R410A	R410A	R410A	R410A	R410A	R410A	R410A	R410A
Refrigerant charge	kg	10,4	14,7	14,7	17,5	17,5	22,3	22,7	32,6	39,8	39,8	45,5	50,9	59,0
Global warming potential (GWP)		2088	2088	2088	2088	2088	2088	2088	2088	2088	2088	2088	2088	2088
Equivalent CO ₂ charge	t	21,8	30,7	30,7	36,5	36,5	46,5	47,4	68,0	83,2	83,2	95,0	106,2	123,1
Water tank volume	l	140	300	300	500	500	500	500	300	500	500	500	500	500

SE/XL/HH - P2S/P2U		532	632	742	862	912	1052	1222	1534	1654	1854	1964	2254	2554
Heating capacity (EN14511) ⁽¹⁾	kW	51,8	59,4	77,1	82,9	87,8	101,9	114,4	126,9	142,2	163,6	184,6	224,7	267,2
Total input power (EN14511) ⁽¹⁾	kW	12,8	14,3	18,6	19,8	21,5	24,2	27,7	30,1	32,3	37,7	42,9	53,3	63,8
COP (EN14511) ⁽¹⁾	W/W	4,04	4,15	4,15	4,20	4,08	4,21	4,13	4,22	4,41	4,35	4,31	4,22	4,19
Energy Class ⁽²⁾		A++	A++	A++	A++	A++	A++	A++	A++	A++	A++	A++	A++	A++
SCOP ⁽²⁾	kWh/kWh	3,95	4,10	4,08	4,13	4,10	4,03	4,00	4,18	4,28	4,25	4,18	4,15	4,13
η _{s,h} ⁽²⁾	%	155	161	160	162	161	158	157	164	168	167	164	163	162
Sound power level ⁽³⁾	dB (A)	76	77	78	78	79	79	80	80	80	80	82	83	84
Sound pressure level ⁽⁴⁾	dB (A)	44	45	46	46	47	47	48	48	48	48	50	51	52
Power supply	V/Ph/Hz	400/3/50	400/3/50	400/3/50	400/3/50	400/3/50	400/3/50	400/3/50	400/3/50	400/3/50	400/3/50	400/3/50	400/3/50	400/3/50
Compressors / Circuits	n° / n°	2 / 1	2 / 1	2 / 1	2 / 1	2 / 1	2 / 1	2 / 1	4 / 2	4 / 2	4 / 2	4 / 2	4 / 2	4 / 2
Fans	n°	2	2	2	3	3	3	4	2	3	3	3	4	4
Refrigerant		R410A	R410A	R410A	R410A	R410A	R410A	R410A	R410A	R410A	R410A	R410A	R410A	R410A
Refrigerant charge	kg	10,4	14,7	16,3	17,5	17,5	22,3	22,7	32,6	39,8	39,8	32,5	50,9	59,0
Global warming potential (GWP)		2088	2088	2088	2088	2088	2088	2088	2088	2088	2088	2088	2088	2088
Equivalent CO ₂ charge	t	21,8	30,7	34,1	36,5	36,5	46,5	47,4	68,0	83,2	83,2	67,8	106,2	123,1
Water tank volume	l	140	300	300	500	500	500	500	300	500	500	500	500	500

Performances are referred to the following conditions:

(1) Heating: Ambient temperature 7°C DB, 6°C WB, water temperature 30/35°C.

(2) Average conditions, low temperature, variable - Reg EU 811/2013

(3) Sound power level in accordance with ISO 3744.

(4) Sound pressure level at 10 mt from the unit in free field conditions in accordance with ISO 3744.

Reversible heating/cooling version (RV)

SE/LS/RV - P2S/P2U		532	632	742	862	912	1052	1222	1534	1654	1854	1964	2254	2554
Heating capacity (EN14511) ⁽¹⁾	kW	53,3	61,8	74,2	85,1	90,9	102,5	118,3	129,0	145,3	165,2	188,7	223,4	269,6
Total input power (EN14511) ⁽¹⁾	kW	13,2	14,7	18,7	20,0	22,1	24,9	28,5	31,2	34,0	39,1	44,8	55,1	65,8
COP (EN14511) ⁽¹⁾	W/W	4,04	4,19	3,97	4,25	4,11	4,12	4,15	4,14	4,27	4,23	4,21	4,06	4,10
Energy Class ⁽²⁾		A++	A++	A++	A++	A++	A++	A++	A++	A++	A++	A++	A++	A++
SCOP ⁽²⁾	kWh/kWh	3,88	3,93	3,90	3,98	3,92	3,93	3,88	3,95	3,93	4,00	3,90	3,88	3,88
$\eta_{s,h}$ ⁽²⁾	%	152	154	153	156	154	154	152	155	154	157	153	152	152
Cooling capacity (EN14511) ⁽³⁾	kW	49,32	57,71	68,9	78,87	83,19	95,32	109,3	112,8	129,4	146,3	162,5	197,4	230,6
Total input power (EN14511) ⁽³⁾	kW	16,42	18,47	24,48	25,78	28,18	31,81	36,3	40,3	42,6	50,2	57,0	69,5	84,6
EER (EN14511) ⁽³⁾	W/W	3,00	3,12	2,81	3,06	2,95	3,00	3,01	2,80	3,04	2,91	2,85	2,84	2,72
Sound power level ⁽⁴⁾	dB (A)	81	81	83	83	83	84	85	86	87	87	87	89	89
Sound pressure level ⁽⁵⁾	dB (A)	49	49	51	51	51	52	53	54	55	55	55	57	57
Power supply	V/Ph/Hz	400/3/50	400/3/50	400/3/50	400/3/50	400/3/50	400/3/50	400/3/50	400/3/50	400/3/50	400/3/50	400/3/50	400/3/50	400/3/50
Compressors / Circuits	n° / n°	2 / 1	2 / 1	2 / 1	2 / 1	2 / 1	2 / 1	2 / 1	4 / 2	4 / 2	4 / 2	4 / 2	4 / 2	4 / 2
Fans	n°	2	2	2	3	3	3	4	2	3	3	3	4	4
Refrigerant		R410A	R410A	R410A	R410A	R410A	R410A	R410A	R410A	R410A	R410A	R410A	R410A	R410A
Refrigerant charge	kg	10,4	14,7	14,7	17,5	17,5	22,3	22,7	32,6	39,8	39,8	45,5	50,9	59,0
Global warming potential (GWP)		2088	2088	2088	2088	2088	2088	2088	2088	2088	2088	2088	2088	2088
Equivalent CO ₂ charge	t	21,8	30,7	30,7	36,5	36,5	46,5	47,4	68,0	83,2	83,2	95,0	106,2	123,1
Water tank volume	l	140	300	300	500	500	500	500	300	500	500	500	500	500

SE/XL/RV - P2S/P2U		532	632	742	862	912	1052	1222	1534	1654	1854	1964	2254	2554
Heating capacity (EN14511) ⁽¹⁾	kW	51,8	59,4	77,1	82,9	87,8	101,9	114,4	126,9	142,2	163,6	184,6	224,7	267,2
Total input power (EN14511) ⁽¹⁾	kW	12,8	14,3	18,6	19,8	21,5	24,2	27,7	30,1	32,3	37,7	42,9	53,3	63,8
COP (EN14511) ⁽¹⁾	W/W	4,04	4,15	4,15	4,20	4,08	4,21	4,13	4,22	4,41	4,35	4,31	4,22	4,19
Energy Class ⁽²⁾		A++	A++	A++	A++	A++	A++	A++	A++	A++	A++	A++	A++	A++
SCOP ⁽²⁾	kWh/kWh	3,95	4,10	4,08	4,13	4,10	4,03	4,00	4,18	4,28	4,25	4,18	4,15	4,13
$\eta_{s,h}$ ⁽²⁾	%	155	161	160	162	161	158	157	164	168	167	164	163	162
Cooling capacity (EN14511) ⁽³⁾	kW	48,0	55,9	70,4	76,4	80,4	91,9	105,7	109,4	124,9	140,1	154,6	198,5	231,8
Total input power (EN14511) ⁽³⁾	kW	16,3	18,4	22,7	25,6	28,1	32,1	36,2	38,9	40,8	49,4	56,0	62,9	77,9
EER (EN14511) ⁽³⁾	W/W	2,86	2,96	3,00	2,90	2,79	2,80	2,84	2,68	2,93	2,73	2,67	2,97	2,83
Sound power level ⁽⁴⁾	dB (A)	76	77	78	78	79	79	80	80	80	80	82	83	84
Sound pressure level ⁽⁵⁾	dB (A)	44	45	46	46	47	47	48	48	48	48	50	51	52
Power supply	V/Ph/Hz	400/3/50	400/3/50	400/3/50	400/3/50	400/3/50	400/3/50	400/3/50	400/3/50	400/3/50	400/3/50	400/3/50	400/3/50	400/3/50
Compressors / Circuits	n° / n°	2 / 1	2 / 1	2 / 1	2 / 1	2 / 1	2 / 1	2 / 1	4 / 2	4 / 2	4 / 2	4 / 2	4 / 2	4 / 2
Fans	n°	2	2	2	3	3	3	4	2	3	3	3	4	4
Refrigerant		R410A	R410A	R410A	R410A	R410A	R410A	R410A	R410A	R410A	R410A	R410A	R410A	R410A
Refrigerant charge	kg	10,4	14,7	16,3	17,5	17,5	22,3	22,7	32,6	39,8	39,8	32,5	50,9	59,0
Global warming potential (GWP)		2088	2088	2088	2088	2088	2088	2088	2088	2088	2088	2088	2088	2088
Equivalent CO ₂ charge	t	21,8	30,7	34,1	36,5	36,5	46,5	47,4	68,0	83,2	83,2	67,8	106,2	123,1
Water tank volume	l	140	300	300	500	500	500	500	300	500	500	500	500	500

Performances are referred to the following conditions:

(1) Heating: Ambient temperature 7°C DB, 6°C WB, water temperature 30/35°C.

(2) Average conditions, low temperature, variable - Reg EU 811/2013.

(3) Cooling: ambient air temperature 35°C, evaporator water temperature in/out 12/7 °C.

(4) Sound power level in accordance with ISO 3744.

(5) Sound pressure level at 10 mt from the unit in free field conditions in accordance with ISO 3744.

Frame

All units are made from hot-galvanised sheet steel, painted with polyurethane powder enamel and stoved at 180°C to provide maximum protection against corrosion. The frame is self-supporting with removable panels. All screws and rivets used are made from stainless steel. The standard colour of the units is RAL9018.

Refrigerant circuit

The refrigerant utilised is R410A. The refrigerant circuit is assembled using internationally recognised brand name components with all brazing and welding being performed in accordance with ISO 97/23. The refrigerant circuit includes: sight glass, filter drier, two thermal expansion valves (one for cooling mode, one for heating mode) with external equalizer, 4 way reversing valve, check valves, liquid receiver, Schrader valves for maintenance and control, pressure safety device (for compliance with PED regulations).

Compressors

The compressors used are three-phase scroll type BPM (brushless permanent magnet) high efficiency, controlled by an Inverter, supplied with a specific design that increases the efficiency of the refrigerant cycle in very low ambient temperature conditions. All sizes use compressors in tandem configuration, and are all optimized for heat pump applications for high seasonal efficiency (SCOP).

The compressors are all supplied with electrical resistance and thermal overload protection. They are all mounted in a dedicated compartment to keep them separated from the airflow. The electric heater is always powered when the compressor is in stand by mode. Maintenance is possible through the front panel of the unit which allows to reach the compressors even when the machine is running.

Source heat exchanger

The source heat exchanger is made from copper pipes and aluminium fins. Dimensioning of the copper pipes and the aluminium fins is optimized in order to obtain excellent performance. The tubes are mechanically expanded into the fins in order to maximise heat transfer. Furthermore, the design guarantees a low air side pressure drop thus enabling the use of low rotation speed (and hence low noise) fans. All heat exchangers are supplied standard with fins hydrophilic coating.

High efficiency E.C. axial fans (VECE)

High efficiency E.C. axial fans, supplied with Brushless DC electric motors electronically commutated (E.C. motors) able to grant the highest energy efficiency class (EFF1), according to the latest EU specifications, with the result of substantial energy consumption reduction for ventilation and noise reduction thanks to the new ultra efficient blade profiling. The fans are statically and dynamically balanced and supplied complete with a safety fan guard complying with the requirements of EN 60335. The fans are installed using a special steel profiled beam who minimize all vibrations and noise emitted. The average nominal rotation speed is 700 rpm. All units

are fitted with a pressure transducer for the control of the evaporation/condensation pressure. All electric motors are fitted with integrated thermal overload protection rating IP54. The motors are fitted with integrated thermal overload protection and have a moisture protection rating of IP 54.

Microprocessors

All units are supplied as standard complete with control panel. The microprocessor controls the following functions: control of the water temperature, antifreeze protection, compressor timing, compressor automatic starting sequence (For multiple compressors), alarm reset.

The control panel is supplied with display showing all operational icons. The microprocessor is set for automatic defrost (when operating in severe ambient conditions) and for summer/ winter change over (only for RV versions).

The control also manages the anti-legionella program, the integration with other heating sources (electric heaters, boilers, solar panels etc), the operation of a three port modulating valve (for diverting to DHW or heating) and both the heating circuit pump and the domestic hot water circuit pump. All units are set up for connection to a site BMS system thus enabling remote control and management.

Electric enclosure

The enclosure is manufactured in order to comply with the requirements of the electromagnetic compatibility standards CEE EN60204. Access to electrical cabinet is quick and easy thanks to hinged panels. The following components are supplied as standard on all units: main switch, a sequence relay that disables the power supply in the event that the phase sequence is incorrect (scroll compressors can be damaged if they rotate in the wrong direction), thermal overloads (protection of pumps and fans), compressor fuses, control circuit automatic breakers, compressor contactors, fan contactors and pump contactors. The terminal board has volt free contacts for remote ON-OFF, Summer/ winter change over (heat pumps only) and general alarm.

Control and protection devices

All units are supplied with the following controls and protections: user water return temperature sensor, antifreeze protection temperature sensor installed on users water output, domestic hot water supply and return temperature sensors (only versions P2S), high pressure and low pressure automatic reset, compressor thermal protection, air fan, thermal protection, pressure transducer (used to optimize the defrost cycle and to adjust the fan speed depending on ambient conditions), flow switch. All units are also fitted with a temperature probe sensor with "Energy Saving" function, supplied in a separate plastic box, which can be used to stop the pump use during periods of stand-by, when the water temperature reaches the set point. Doing this the power consumption of the unit is strongly reduced.

Electronic expansion valve (VTEE)

The use of the electronic thermostatic valve is particularly suitable for units operating under very variable load conditions. The electronic expansion valve enables the maximum possible efficiency to be achieved by maximizing the evaporator heat exchange, minimizing the reaction time to load variations and optimizing the su-

perheat . The use of the electronic thermostatic valve is particularly suitable for units operating under very variable load conditions.

Versions

Version P2U

This is a two pipe version that can produce hot water for heating (HH heating only) and hot or cold water in the RV version. The RV is used with two pipe water based change-over systems. It is not able to produce domestic hot water.

Version P2S

This is a two pipe version that can, in addition to producing hot water for heating (HH version) and hot and cold water in the RV version can also generate domestic hot water. The controller has dual heating set points (heating and DHW) and can also control a three port diverting valve that directs the DHW to the cylinder. DHW production has priority irrespective of the mode of operation of the unit. The unit is normally used with two pipe water based change-over systems.

Version HH

HH heating only versions are available in the P2U and P2S configuration only.

Version RV

This version uses 2 hydraulic connections and is able to produce hot water in winter and cold water in summer. The unit is combined with a 2-pipe system.

SE Version

Standard efficiency version, according to current standard. Unit equipped with EC fans.

Version LS

This version includes the complete acoustic insulation of the unit with compressor jackets and insulating material made with high density media and the interposition of heavy bitumen layer.

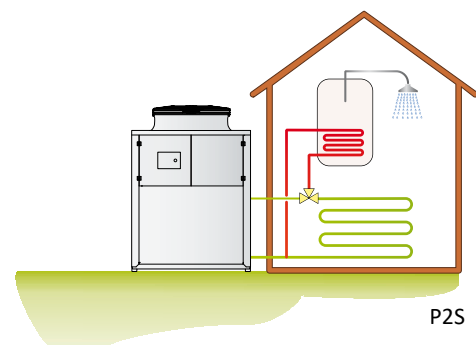
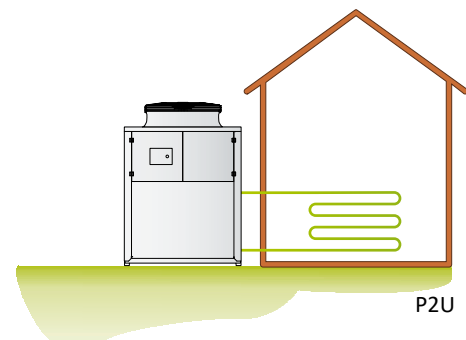

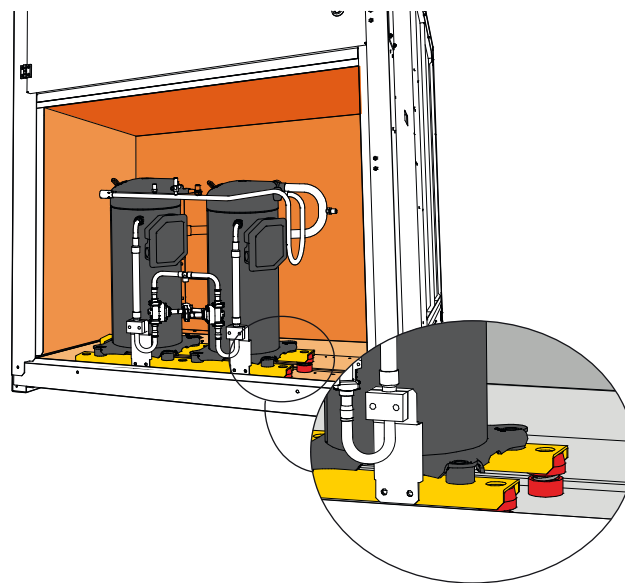

XL Super low noise version

All units in XL super low noise version are supplied, as standard, with the latest 'Floating Frame' technology that completely isolates the compressors from the main casing, thereby eliminating vibration and noise from this source. The 'Floating Frame' is a special vibration and acoustic damping system that consists of a base plate and acoustic enclosure that houses the compressors. The base plate is separated from the supporting frame of the unit by soft steel springs that have a high damping power. Within the enclosure, the compressors are mounted on rubber shock absorbers on the floating base plate. The enclosure is manufactured from galvanized steel sandwich panels that have a micro-perforated inner skin and a core of 30 mm thick, high density (25 kg/m³). The entire arrangement provides a double damping system and acoustic attenuation. The compressor refrigerant pipes are connected to the refrigerant circuit through "anaconda" flexible connections. Flexible connections are also used on the water pipework within the unit. The combination of these systems results in an overall noise reduction in the region of 5-7 dB(A).

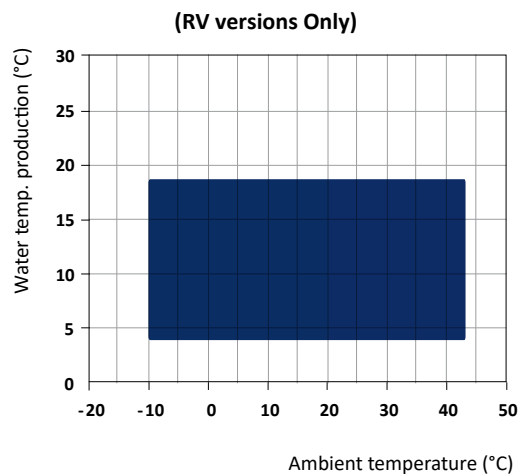
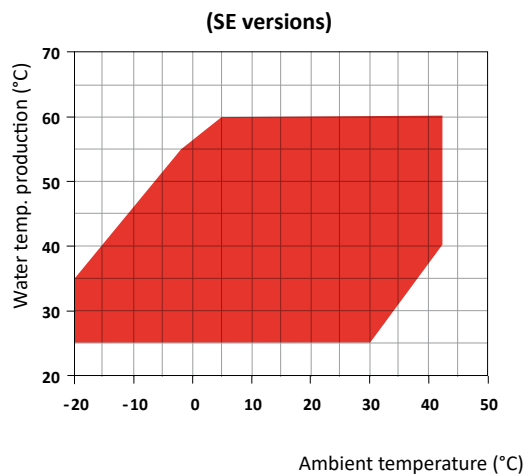

Operation limits



-  Heating mode
-  Cooling mode

LHi SE/HH-RV	P2S/P2U	532	632	742	862	912	1052	1222
Flow switch		●	●	●	●	●	●	●
"Floating frame" Technology - XL Version		●	●	●	●	●	●	●
E.C. fans - SE versions	VECE	●	●	●	●	●	●	●
Condensate discharge drip tray with antifreeze heater	BRCA	○	○	○	○	○	○	○
Antifreeze kit for 2 pipe units	RAEV2	○	○	○	○	○	○	○
Electronic soft starter	DSSE	○	○	○	○	○	○	○
Serial interface card RS485	INSE	●	●	●	●	●	●	●
Rubber anti-vibration mountings	KAVG	○	○	○	○	○	○	○
Remote control panel	PCRL	○	○	○	○	○	○	○
Electronic expansion valve	VTEE	●	●	●	●	●	●	●
Power factor correction system	RICO	○	○	○	○	○	○	○
Power factor correction system with soft starter	RICSS	○	○	○	○	○	○	○
Spring vibration dampers	KAVM	○	○	○	○	○	○	○
Coil protection grid	GBPE	○	○	○	○	○	○	○
Shut-off valve on compressor discharging side	RDCO	○	○	○	○	○	○	○
Shut-off valve on compressor suction side	RHCO	○	○	○	○	○	○	○
Hydraulic kit with one inverter pump	A1VSU	○	○	○	○	○	○	○
Hydraulic kit with one pump without tank	A1NTU	○	○	○	○	○	○	○
Hydraulic kit with one higher available pressure pump	A1HPU	○	○	○	○	○	○	○
Hydraulic kit with two pumps without tank	A2NTU	○	○	○	○	○	○	○
Hydraulic kit with tank and one inverter pump	A1VVU	○	○	○	○	○	○	○
Hydraulic kit with one pump with tank	A1ZZU	○	○	○	○	○	○	○
Hydraulic kit with tank and one higher available pressure pump	A1HHU	○	○	○	○	○	○	○
Hydraulic kit with two pumps with tank	A2ZZU	○	○	○	○	○	○	○
Buffer tank and pump for internal loop	BUF4A	○	○	○	○	○	○	○
Antifreeze kit in combination with A1VSU / A1NTU / A1HPU *	KPU1	○	○	○	○	○	○	○
Antifreeze kit in combination with A2NTU *	KPU2	○	○	○	○	○	○	○
Antifreeze kit in combination with pump and buffer tank *	KPSU1	○	○	○	○	○	○	○
Antifreeze kit in combination with pumps and buffer tank *	KPSU2	○	○	○	○	○	○	○

* Includes accessory RAEV2

● Standard ○ Optional – Not available

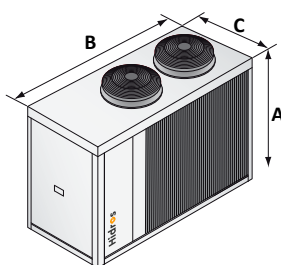

SE/LS 532
SE/XL 532

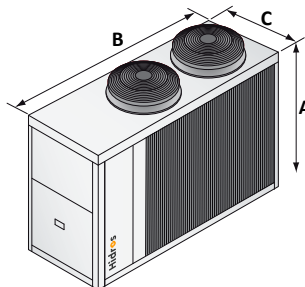

SE/LS 632 - 742
SE/XL 632

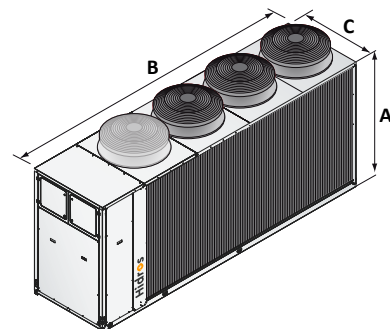

SE/LS 862 - 912 - 1052 - 1222
SE/XL 742 - 862 - 912 - 1052 - 1222

		532	632	742	862	912	1052	1222
A (mm)	SE/LS	1690	1840	1840	1840	1840	1840	1840
B (mm)	SE/LS	2400	2905	2905	3905	3905	3905	3905
C (mm)	SE/LS	1145	1145	1145	1145	1145	1145	1145
kg	SE/LS	810	940	950	970	1270	1360	1410
A (mm)	SE/XL	1690	1840	1840	1840	1840	1840	1840
B (mm)	SE/XL	2400	2905	3905	3905	3905	3905	3905
C (mm)	SE/XL	1145	1145	1145	1145	1145	1145	1145
kg	SE/XL	830	960	970	990	1290	1380	1430

LHi SE/HH-RV	P2S/P2U	1534	1654	1854	1964	2254	2554
Flow switch		●	●	●	●	●	●
“Floating frame” Technology - XL Version		●	●	●	●	●	●
E.C. fans - SE versions	VECE	●	●	●	●	●	●
Condensate discharge drip tray with antifreeze heater	BRCA	○	○	○	○	○	○
Antifreeze kit for 2 pipe units	RAEV2	○	○	○	○	○	○
Electronic soft starter	DSSE	○	○	○	○	○	○
Serial interface card RS485	INSE	●	●	●	●	●	●
Rubber anti-vibration mountings	KAVG	○	○	○	○	○	○
Remote control panel	PCRL	○	○	○	○	○	○
Electronic expansion valve	VTEE	●	●	●	●	●	●
Power factor correction system	RICO	○	○	○	○	○	○
Power factor correction system with soft starter	RICSS	○	○	○	○	○	○
Spring vibration dampers	KAVM	○	○	○	○	○	○
Coil protection grid	GBPE	○	○	○	○	○	○
Shut-off valve on compressor discharging side	RDCO	○	○	○	○	○	○
Shut-off valve on compressor suction side	RHCO	○	○	○	○	○	○
Hydraulic kit with one inverter pump	A1VSU	○	○	○	○	○	○
Hydraulic kit with one pump without tank	A1NTU	○	○	○	○	○	○
Hydraulic kit with one higher available pressure pump	A1HPU	○	○	○	○	○	○
Hydraulic kit with two pumps without tank	A2NTU	○	○	○	○	○	○
Hydraulic kit with tank and one inverter pump	A1VVU	○	○	○	○	○	○
Hydraulic kit with one pump with tank	A1ZZU	○	○	○	○	○	○
Hydraulic kit with tank and one higher available pressure pump	A1HHU	○	○	○	○	○	○
Hydraulic kit with two pumps with tank	A2ZZU	○	○	○	○	○	○
Buffer tank and pump for internal loop	BUF4A	○	○	○	○	○	○
Antifreeze kit in combination with A1VSU / A1NTU / A1HPU *	KPU1	○	○	○	○	○	○
Antifreeze kit in combination with A2NTU *	KPU2	○	○	○	○	○	○
Antifreeze kit in combination with pump and buffer tank *	KPSU1	○	○	○	○	○	○
Antifreeze kit in combination with pumps and buffer tank *	KPSU2	○	○	○	○	○	○

* Includes accessory RAEV2

● Standard ○ Optional – Not available

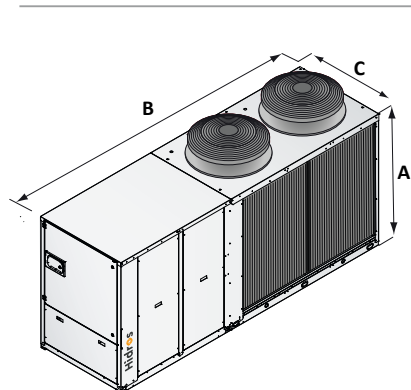

SE/LS 1534
SE/XL 1534

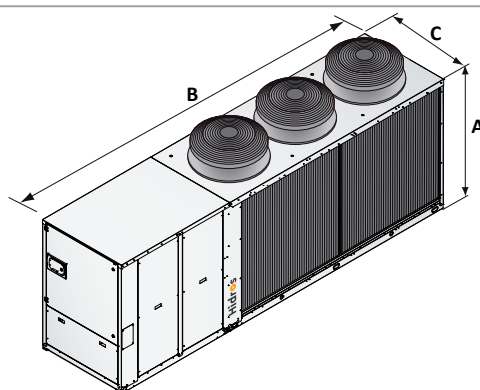

SE/LS 1654 - 1854 - 1964
SE/XL 1654 - 1854 - 1964

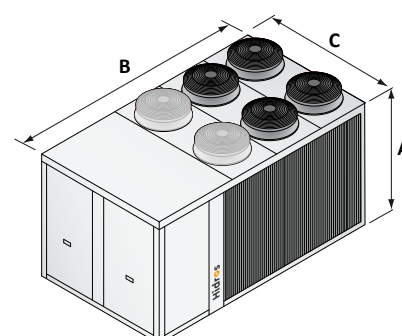

SE/LS 2254 - 2554
SE/XL 2254 - 2554

		1534	1654	1854	1964	2254	2554
A (mm)	SE/LS	1890	1890	1890	1890	2350	2350
B (mm)	SE/LS	3695	4695	4695	4695	4205	4205
C (mm)	SE/LS	1145	1145	1145	1145	2190	2190
kg	SE/LS	1460	1810	1830	2130	2680	2720
A (mm)	SE/XL	1890	1890	1890	1890	2350	2350
B (mm)	SE/XL	3695	4695	4695	4695	4205	4205
C (mm)	SE/XL	1145	1145	1145	1145	2190	2190
kg	SE/XL	1480	1830	1850	2150	2700	2740